

Contest® 

 audiophony®  
EQUIPMENTS

play2Run®  
Sport Audio Equipment

# LIGHT & SOUND

Edition  
2017

The image features a minimalist design with several thin black lines on a white background. A large triangle is formed by lines extending from the top-left and top-right corners towards a central point. From this central point, two lines extend downwards to the bottom-left and bottom-right corners, creating a smaller triangle. Additionally, a line extends from the top-right corner towards the bottom-right corner, and another line extends from the top-left corner towards the bottom-left corner, forming a larger, irregular shape that encompasses the other elements.

# **SUMMARY**



P3-27  
LE CLUB

P28-51  
LIGHT PRO

P52-87  
LIGHT PERFORMERS

**Contest**® 

P88-97  
MINI LIGHT

P98-105  
LIGHT DJ

P106-115  
SCENOGRFX

P116-167  
CONTEST  
ARCHITECTURE

P168-183  
LIGHT CONTROL

P184-195  
STAGE PLATFORM

P196-221  
CONTESTAGE

P222-225  
STANDS AND STAGE  
ACCESSORIES

P226-227  
LAMPS

 **audiophony**®  
EQUIPMENTS

P228-239  
MIDI CONTROLLERS AND  
MULTIMEDIA PLAYERS

P240-245  
HEADPHONES

P246-251  
MICROPHONES

P252-257  
MIXERS

P258-263  
AMPLIFIERS

P264-265  
AUDIO PROCESSING

P266-303  
SPEAKERS

P304-323  
PORTABLE SOUND SYSTEM

P324-375  
COMMERCIAL AUDIO SERIES

P376-384  
STAGE ACCESSORIES

P386-393  
CORDS AND CABLES

P394-397  
SPEAKER  
COMPONENTS

P398-402  
PLAY2RUN

**play2Run**®  
Sport Audio Equipment



Toujours au diapason la famille s'agrandit  
pour monter en gamme\*

\*The family gets bigger to move harmony to the next level



La gamme Le Club en vidéo  
Le Club on Youtube

by **Contest**<sup>®</sup> 



**RADIUS515**



**Natural born performers**

LE CLUB is a range of ultra-powerful projectors designed to be fully in harmony with the music. This series has just celebrated its 2<sup>nd</sup> birthday and keeps rocking the dancefloor day and night.

**New exclusive projectors**

Our series gets bigger by welcoming 4 new products. Our KADE0460Q, SUBAR103W, and RADIUS515 bring to you a delightful mix of power, brightness and colours.

**LeClub, a series with diversity**

Diversity is what defines best this series with exclusive effects and products designed for both modern animations and more traditional atmospheres.

BEAM effects with our SWORD5R, RAY1R and THUNDER80 moving heads

SPOT effects with our CYCLONE120R, BLAST60 and MINI-HEAD10W

WASH effects with our HEZO120Z and HEZO300Z

And even multi-beam animation effects thanks to the FIRESTORM4x10, SUNBAR10W and RADIUS515

Selecting the number of channels grants you total control over every function of your projectors, or just direct access to the essential features.

Thereby you get to start your projector in 1-channel music-sensitive mode, or create your own show piece by piece for maximum precision.

**KADE0460QC**



**Easy to control**

LE CLUB makes a point of being easy-to-use for beginners and professionals. Effects can be music-synchronised, Master/Slave mode and programs can be controlled with an EASY-2 remote control or any DMX device.



**HEZO300ZR**



**SUNBAR10W**

# NOUVEAU KADEO460QC

Le spot 2 en 1  
Projection & Animation\*

\*2-in-1 spot  
Projection & Animation

Un mono faisceau  
zoomable à volonté  
d'une uniformité exceptionnelle

One single beam with on-demand zoom  
and incredible homogeneity

4 faisceaux indépendants  
avec rotation inédite  
pour un effet animation

4 independent beams with exclusive  
rotation to create animation effects

by **Contest**<sup>®</sup>





# KADE0460 QC

4 x 60W 4-in-1 LEDs DMX projector with zoom and effect

**The encounter between projection and animation effect**

ref 10652

- + Powerful projector with zoom & animation effect
- + Explosive beams
- + Incredible colour mixing

## BUILT-IN ZOOM

KADE0460QC revolutionizes traditional lighting.

This animation projector is equipped with 4 x 60W OSRAM 4-in-1 LEDs. They became famous thanks to their brightness, and once combined to a high-quality optical system they deliver an exceptional and consistent colorimetric output.

Moreover, thanks to its 6° to 80° zoom, KADE0460QC will perfectly adapt to small and bigger surfaces, to ensure maximum versatility.

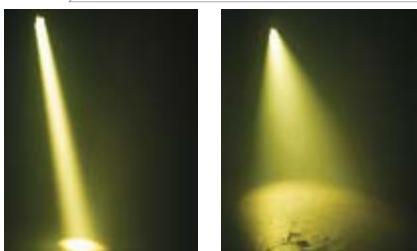

## MULTIPLY YOUR EFFECTS

KADE0460QC is a 2-in-1 projector able to create incredible animation effects by splitting up the light output into 4 beams. The rotation of its optical system allows you to control its indexation, rotation direction and speed, to get the very best out of the zoom and create spectacular effects.

It can be used in DMX, automatic or music-sensitive mode, while its extra-large double fixation bracket offers you the possibility to attach it to a structure or use it on the ground, which comes in really handy both for installations and exhibitions.



## TECHNICAL SPECIFICATIONS :

- |                          |                   |                            |                               |
|--------------------------|-------------------|----------------------------|-------------------------------|
| LED<br>4 LED 60W<br>RGBW | Zoom<br>6°-80°    | DMX<br>1,10,13<br>channels | Auto                          |
| Music                    | Master/slave      | Strobe                     | Cord with plug<br>240V - 50Hz |
| 350 W                    | 342x320x305<br>mm | 8 kg                       | Double fixation<br>bracket    |

# SUNBAR 103W

Light bar with 10 x 3W warm white LEDs with and pixel control

**An essential effect for stage lighting.**

ref 10653

An essential effect for stage lighting.

Our SunBar103W is a 10 x 3W LEDs bar adapted to any kind of situation.

Its 17 pixel effect programs can be accessed automatically or via the DMX menu, thanks to its 5 modes. Its strong chassis, its fixation bracket and its very complete panel of connectors ensure the SunBar103W is as easy to set up and use as possible.

With an electricity unit consumption of only 36W, decreasing the power of your effects and limiting the number of products because of electrical restrictions is now over.

This major asset allows you to multiply special effects, should it be for installations or stages.



- + "Pixel" effect
- + Individual LED control
- + 17 "Pixel" sequence programs















## FLY4-SUNBAR103

Flight-case for 4x SUNBAR103W

ref 10738



### TECHNICAL SPECIFICATIONS :

- |   |   |   |  |   |
|---|---|---|--|---|
|  LED<br>10 x 3 W warm white LEDs |  Pixel control |  DMX<br>1,3,5,10,15 channels |  Auto                                   |  Music-sensitive |
|  Master/Slave                    |  Strobe        |  Retaining bracket for hooks |  powerCON IN/OUT Sockets<br>240V - 50Hz |  36 W            |
|  999 x 170 x 50 mm               |  3,4 kg        |   |  |   |



# RADIUS 515

Beam effect with 5 x 15W 4-in-1 RGBW LEDs

**The pixel "Beam"**

ref 10667

NEW















- + Beam effect
- + LED 15W RGBW
- + Beam angle 4°
- + Each beam can be controlled individually

Our RADIUS-515 features the 15W RGBW LED already used for our ROTOR7i, FLAG25i and PIN15QC. Combined with the same optical collimator, this source is able to deliver a very narrow beam.

Each beam can be controlled individually to create powerful pixel effects.

## TECHNICAL SPECIFICATIONS :

|  |  |   |  |  |
|--|--|---|--|--|
| <br>5 x 15 W<br>4-in-1 RGBW<br>LEDs | <br>Pixel control | <br>1,2,10,22,26<br>channels   | <br>Auto                                      | <br>Music sensitive |
| <br>Master/slave                    | <br>Strobe        | <br>Double fixation<br>bracket | <br>powerCON<br>IN/OUT sockets<br>240V - 50Hz | <br>80 W            |
| <br>525 x 280 x<br>250 mm           | <br>5,8 kg        |   |  |  |





# SWELL 6x10WH

6x10 W white LEDs multi-beam rotating bar

**Adding another level of animation**







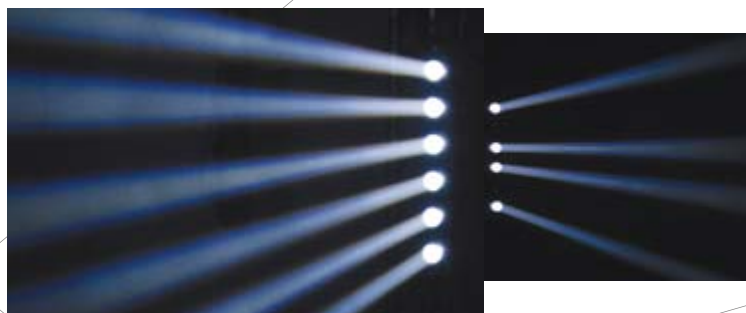







ref 10260

The SWELL-6x10WH features 6x10W white LEDs with a 240° rotation angle. The 6 LEDs produce breathtaking, extremely fast chaser and strobe effects. Daisy-chain several SWELL-6x10WH to create magnificent and ultra-dynamic shows. It works wonders with stages, clubs and nomad installations.

- + 6x10W White LEDs
- + High-precision beam
- + 240° bar rotation
- + Music-sensitive built-in programs



## TECHNICAL SPECIFICATIONS :

- |   |  |   |   |  |
|---|--|---|---|--|
|  <b>LED</b><br>6 x 10-W white LEDs |  <b>Pixel control</b>                         |  <b>Aperture angle: 6°</b> |  <b>DMX</b><br>1-13 channels |  <b>Auto</b>          |
|  <b>Music-sensitive</b>            |  <b>Master/Slave</b>                          |  <b>Bar : 240°</b>         |  <b>Strobe</b>               |  <b>Hook fixation</b> |
|  <b>Easy 2</b>                     |  <b>240 V - 50 Hz IEC IN/OUT power socket</b> |  <b>65 W</b>               |  <b>843 x 170 x 84 mm</b>    |  <b>4.9 kg</b>        |

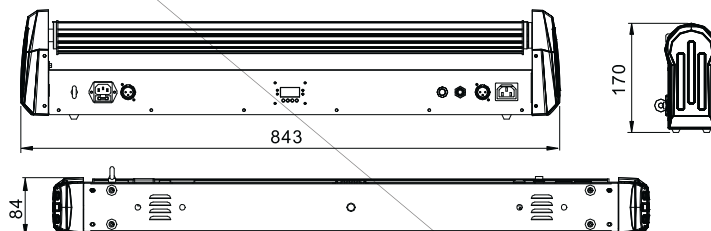

# FIRESTORM 4x10

4x10W RGBW LEDs 4-projector bar with Pan and Tilt movements  
**It is going all over the place**



The FIRESTORM-4x10 is a 5-dimension projector. The projector bar is in constant movement and the 4 independent projectors move on their own as well. We are sure this next-gen projector will very quickly make its mark in the lighting world. The on-board technology and built-in programming is in line with LE CLUB series high standards and allow you to whether use the music-sensitive mode programs, or take full control of the projector via its DMX interface to create the exact show you want.















## FIRESTORM 4x10QC

ref 10292

- + 4x10W Quadricolor LEDs
- + Independent PAN movements for each projector
- + The whole bar rotates on a Tilt axis
- + Music-sensitive built-in programs



### TECHNICAL SPECIFICATIONS :

|   |  |   |  |  |
|---|--|---|--|--|
|  <b>LED</b><br>4 x 10 W RGBW LEDs - QC |  <b>Pixel control</b>                         |  <b>Aperture angle: 6°</b> |  <b>DMX</b><br>1-27 channels - QC |  <b>Auto</b>              |
|  <b>Music-sensitive</b>                |  <b>Master/Slave</b>                          |  <b>Pan 90° Tilt 240°</b>  |  <b>Strobe</b>                    |  <b>2xOmega fixations</b> |
|  <b>Easy 2</b>                         |  <b>240 V - 50 Hz IEC IN/OUT power socket</b> |  <b>80 W</b>               |  <b>791 x 152 x 232 mm</b>        |  <b>10.2 kg</b>           |

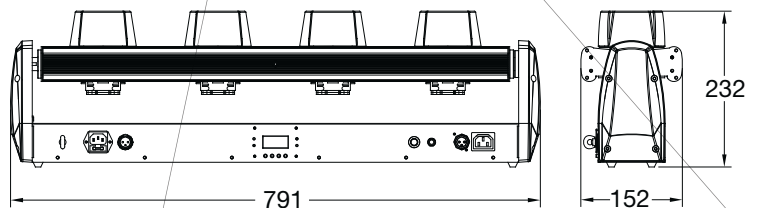

## FIRESTORM 4x10WH

ref 10291

- + 4x10W White LEDs
- + Independent PAN movements for each projector
- + The whole bar rotates on a Tilt
- + Music-sensitive built-in programs

### FLY-FIRESTORMx2

Flight-case for 2 FIRESTORM  
 ref 10339



# HELIWAVE 8x10

2x4 beams animation projector with non-stop rotation

**It is very much like a wave effect, with a non-stop rotation**

The HELIWAVE-8x10QC/WH is the worthy heir of the famous WAVE-8x10 projector. We added a non-stop panoramic rotation to create countless chaser and crossed-light effects. It features 8x10W white or quadrichromic LEDs to flood dance floors and stages with ultra-dynamic beams. The built-in programs are in line with the LE CLUB series high standards and allow you to create your own sequences or let it work on its own, with the music-sensitive modes.

















## HELIWAVE 8x10WH

ref 10293

- + 8x10W White LEDs
- + Non-stop rotation
- + Tilt movements on a 145° angle



### TECHNICAL SPECIFICATIONS :

- |  |  |   |  |  |
|--|--|---|--|--|
|  <b>LED</b><br>8x10W RGBW LEDs - QC<br>8x10W Dazzling white LEDs - WH |  <b>Pixel control</b>                     |  <b>Aperture angle: 6°</b>                         |  <b>DMX</b><br>1-42 channels - QC<br>1-18 channels - WH |  <b>Auto</b>              |
|  <b>Music-sensitive</b>   |  <b>Master/Slave</b>                      |  <b>Pan: infinite</b><br><b>145° Tilt rotation</b> |  <b>Strobe</b>  |  <b>2xOmega fixations</b> |
|  <b>Easy 2</b>  |  <b>240 V - 50 Hz</b><br>IEC power socket |  <b>QC : 114 W</b><br><b>WH : 106 W</b>            |  <b>393 x 232 x 239 mm</b>                              |  <b>9.6 kg</b>            |

### FLY-HELIWAVEx2

Flight-case for 2 HELIWAVE  
ref 10340

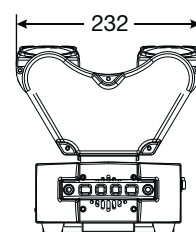
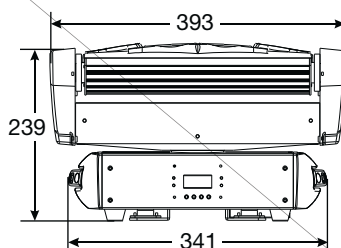

# HELIPTIC 9x10WH

3x3 beams with non-stop PAN rotation animation projector

**Limitless rotation effects**

The HELIPTIC-9x10WH/QC is the next-gen multibeam animation projector. Each of the 3 bars is equipped with 3x10W white LEDs ensuring a constant panoramic rotation to create hypnotic chaser and crossed-light effects. The built-in programs are, as always, ultra-efficient and easy to use. The HELIPTIC-9x10WH/QC can be controlled in DMX, which makes it perfect for nomad and permanent installations.

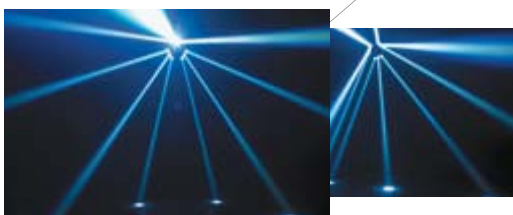















## HELIPTIC 9x10WH

ref 10311

- + 9x10W White LEDs
- + Non-stop rotation
- + Tilt movements on a 145° angle
- + Dance floor ultra-dynamic effect



### TECHNICAL SPECIFICATIONS :

- |   |  |   |   |  |
|---|--|---|---|--|
| <br>9x10W White LEDs | <br>Pixel control                     | <br>Aperture angle: 6° | <br>1-20 channels      | <br>Auto              |
| <br>Music-sensitive  | <br>Master/Slave                      | <br>Pan: infinite      | <br>Strobe             | <br>2xOmega fixations |
| <br>Easy 2           | <br>240 V - 50 Hz<br>IEC power socket | <br>145° Tilt rotation | <br>429 x 347 x 208 mm | <br>9.6 kg            |

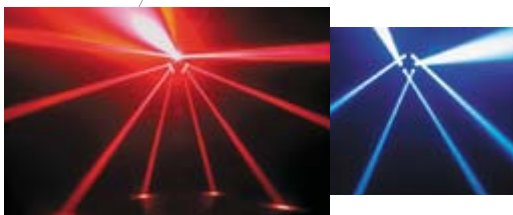
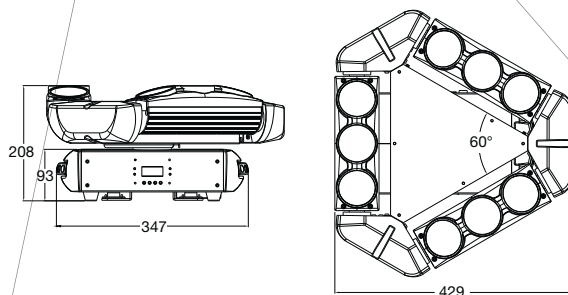

### FLY-HELIPTIC

Flight-case for 1 HELIPTIC  
 ref 10341



## HELIPTIC 9x10QC

ref 10360

- + 9x10W Quadricolour LEDs
- + Non-stop rotation
- + Tilt movements on a 145° angle
- + Dance floor ultra-dynamic effect







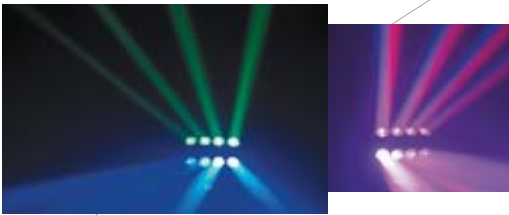









# STORM 8x10

Double four eyes bar moving head  
**Multi-beam going crazy**



## TECHNICAL SPECIFICATIONS :

|   |  |   |  |  |
|---|--|---|--|--|
| <br>8x10W RGBW LEDs - QC | <br>Pixel control                 | <br>6° aperture        | <br>1 à 37 channels to use QC | <br>Auto            |
| 8 LEDs dazzling white - WH  |  |   | 1 à 13 to use WH   |  |
| <br>Music-sensitive      | <br>Master/Slave                  | <br>Pan 540° Tilt 230° | <br>Strobe                    | <br>Omega fixations |
| <br>Easy 2               | <br>1 IEC IN/OUT 240V - 50Hz plug | <br>100 W              | <br>414 x 153 x 376 mm        | <br>6.5 kg          |

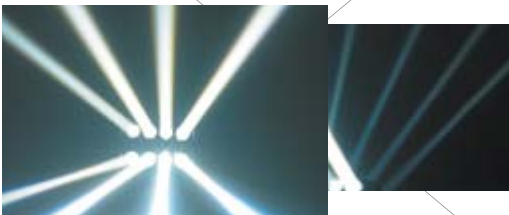

## FLY2CLUB-S2

ref 10248

Flight case for 2x  
STORM 8X10



The STORM-8 multibeam moving heads are formidable live performers. The 3-rotation system uses the 8 beams at their best and creates the illusion there are several projectors acting altogether to create this incredible show. The built-in programs allow you to design your own show or let the STORM-8 adapt to the music.

The STORM-8X10QC features 8x10W quadrichromic LEDs to create incredible colour effects.



## STORM 8x10QC

ref 10172

- + Multibeam effect
- + Double Tilt rotation and Pan rotation
- + Control each LED individually
- + Crossed light effects



## STORM 8x10WH

ref 10173

The STORM-8x10WH produces an incredible brightness thanks to its 8x10W «Pure White» LEDs.

# WAVE 8x10

Motorized LED multibeam bar  
**Ultra-dynamic multibeam**



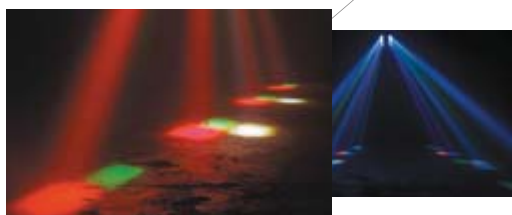











The WAVE-8 is versatile and creates incredible crossed light effects. It is very compact and can be set up almost everywhere to flood large spaces with colours. Its built-in programs allow you to synchronise its movements to the music, or create flamboyant sequences.



The WAVE-8X10QC features 8x10W quadrichromic LEDs to create incredible colour effects.



### TECHNICAL SPECIFICATIONS :

- |   |   |   |  |  |
|---|---|---|--|--|
| <br>8x10W RGBW LEDs - QC | <br>Pixel control                          | <br>6° aperture  | <br>1 - 36 channels to use QC | <br>Auto            |
| 8 dazzling white LEDs - WH  | <br>Music-sensitive                        | <br>Master/Slave | <br>Pan 145°                  | <br>Strobe          |
| <br>Easy 2               | <br>IEC power socket IN/OUT<br>240V - 50Hz | <br>85 W         | <br>395 x 234 x 180 mm        | <br>Omega fixations |
|   |   |   | <br>4,9 kg                    |  |



- + Multibeam effect
- + Double Tilt rotation
- + Control each LED individually
- + Crossed light effects

## WAVE 8x10QC

ref 10170

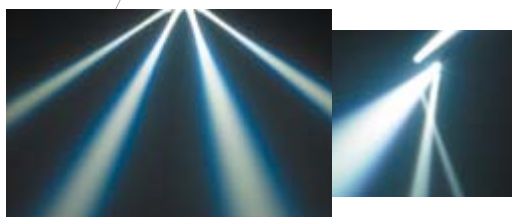

## WAVE 8x10WH

ref 10171

The WAVE-8x10WH produces an incredible brightness thanks to its 8x10W «Pure White» LEDs.

### FLY2CLUB-S1

For Typhoon/Thunder/Cyclone/  
Wave/Hezo120Z  
ref 10247



# BEAM 4x10

4x10W LED multibeam bar

**Compact multibeam effects**



The BEAM-4 is dedicated to animations and ambient lighting. Each LED can be controlled individually, and the BEAM-4 can be used both suspended or on the ground thanks to its DMX interface and the EASY-2 remote control. It also allows you to access several built-in music-sensitive programs.

The BEAM-4X10QC features 4x10W quadrichromatic LEDs to create incredible colour effects.



# BEAM 4x10QC

ref 10179

- + New multibeam effects
- + Control each LED individually to create incredible effects

















The BEAM-4x10WH produces an incredible brightness thanks to its 4x10W «Pure White» LEDs.

# BEAM 4x10WH

ref 10180

### TECHNICAL SPECIFICATIONS :

- |  |   |   |  |  |   |  |
|--|---|---|--|--|---|--|
|  LED<br>8x10W RGBW LEDs- QC |  Pixel control   |  6° aperture |  DMX<br>1 - 36 channels to use QC |  Auto |  Music-sensitive   |  Master/Slave |
|  Strobe                     |  Omega fixations |  Easy 2      |  1 IEC IN/OUT 240V - 50Hz plug    |  45 W |  380 x 165 x 80 mm |  2.7 kg       |



# SWORD 5R

BEAM moving head with Philips® MSD PLATINUM 5R lamp

**Le Club has its own BEAM5R**

ref 10409







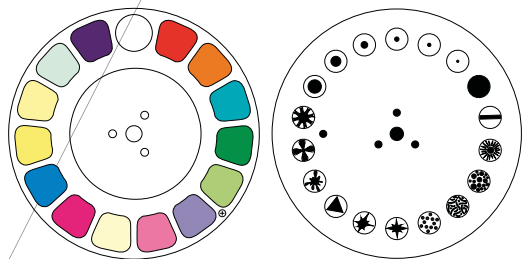
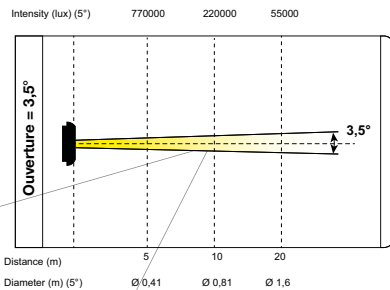
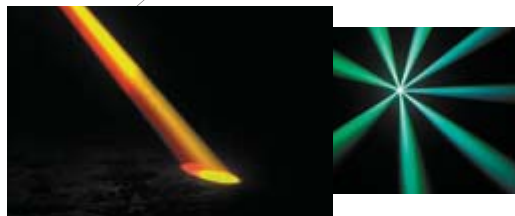
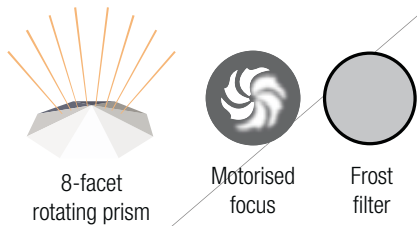









SWORD5R is a "BEAM" moving head with Philips MSD Platinum 5R lamp. It is also equipped with a high-quality optical system allowing a 3.5° aperture. Colour wheel with 14 colours + open, gobo wheel with 17 gobos + open and 8-facet rotating prism. We also added a Frost filter, motorized focus and strobe with variable speed. Needless to say it is incredibly powerful and precise.

SWORD5R: This is what any professional and beginner needs.

- + Philips MSD Platinum 5R Lamp
- + Motorized focus
- + 14 colours + open
- + 17 gobos + open
- + 8-facet rotating prism and Frost filter
- + Dimmer / strobe



**TECHNICAL SPECIFICATIONS :**

- |   |  |   |   |   |   |
|---|--|---|---|---|---|
|  <b>LAMPE</b><br>Philips® MSD PLATINUM 5R - 8000°K |  <b>Beamwidth</b><br>3.5° |  <b>DMX</b><br>1 - 16 channels                                     |  <b>Auto</b>                   |  <b>Music-sensitive</b>    |  <b>Master/slave</b> |
|  <b>Pan 540°</b><br>Tilt 270°                      |  <b>14 colours + open</b> |  <b>17 gobos including 6 beam reducers &amp; gobo shake effect</b> |  <b>8-facet rotating prism</b> |  <b>Strobe</b>             |  <b>Frost filter</b> |
|  <b>Motorized focus</b>                            |  <b>2xOmega fixations</b> |  <b>powerCON IN/OUT</b><br>240V - 50Hz                             |  <b>270 W</b>                  |  <b>500 x 394 x 325 mm</b> |  <b>18 kg</b>        |



**FLY-FLEX15R-SWORD5Rx2**

Flight-case for 2x SWORD-5R  
 ref 10343

This flight case has been specifically designed to safely transport two of your SWORD5R projectors and all their accessories.

# RAY1R

Très compacte mais reconnue pour sa puissance\*

\*Compact yet famous for its power



by **Contest**<sup>®</sup>



# RAY 1R

Beam moving head with HRI 100W OSRAM® lamp

**The most compact discharge beam moving of its category**

ref 10410

Let's check under the hood!

A brand new lamp plus a high-quality optical system gave birth to this powerful, fast and light moving head while preserving an excellent brightness and functionalities.







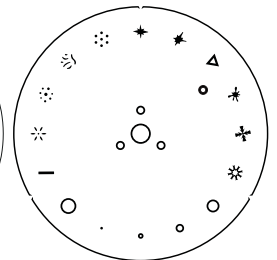
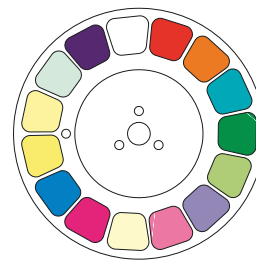
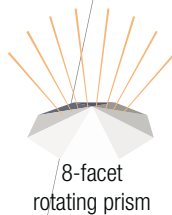
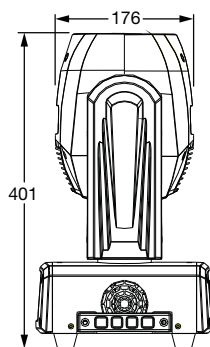
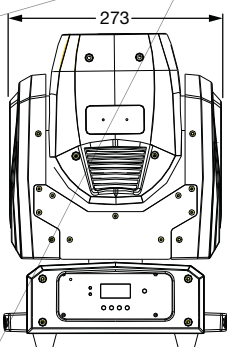









It has everything the big ones have!

Despite its size, it features all the functions you need: colour wheel with 14 colours + open, gobo wheel with 15 gobos + open and 8-facet rotating

- + SIRIUS HRI 100 W OSRAM® Lamp
- + Ultra-compact
- + 14 colours + open
- + 15 gobos + open
- + 8-facet rotating prism
- + Light output: 76000 Lux at 10 m



## TECHNICAL SPECIFICATIONS :

|  |   |   |   |   |   |
|--|---|---|---|---|---|
|  <b>LAMPE</b> |  |  |  |  |  |
| SIRIUS HRI 100W  | Beamwidth 3°  | 1 to 14 channels  | Auto  | Music-sensitive   | Master/Slave  |
|               |  |  |  |  |  |
| Pan 540°<br>Tilt 270°  | 14 colours + open   | 1 gobo wheel with 15 gobos including 4 beam reducers & gobos shake effect           | 8-facet rotating prism  | Strobe  | Omega Fixation  |
|               |  |  |  |   |   |
| powerCON IN/OUT<br>240V - 50Hz   | 190 W   | 401 x 273 x 176 mm  | 9 kg  |   |   |



## FLY-RAY1Rx4

Flight-case for 4 RAY1R

ref 10610

This flight case has been specifically designed to safely transport four of your RAY1R projectors and all their accessories.

# THUNDER

# 80

80W beam moving head

**Narrow, precise, powerful**

ref 10175







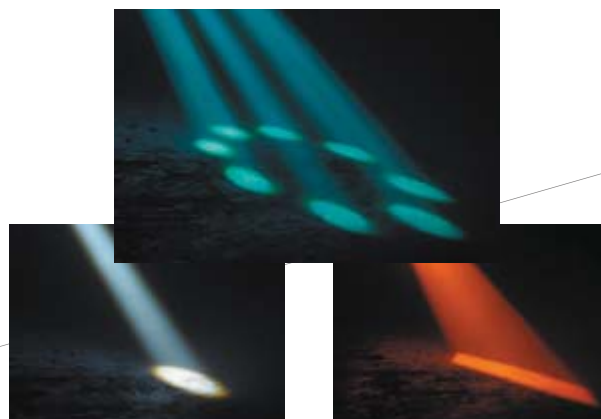









The THUNDER-80 is a beam moving head producing narrow but super-powerful beams. It is incredibly fast and smooth. The built-in programs are very easy to use and have all the features you will ever need. Beginners and pro can now create perfectly synchronised shows.



- + 80W LED beam effect
- + Highly visible beam
- + Rotating gobos, colour wheels and strobe effect



### TECHNICAL SPECIFICATIONS :

- |   |   |  |   |
|---|---|--|---|
| <br>1x80W CW<br>LED                          | <br>6°<br>aperture | <br>1-11 channels         | <br>Auto                 |
| <br>Music-sensitive                          | <br>Master/Slave   | <br>Pan 540°<br>Tilt 270° | <br>8 colours<br>+ white |
| <br>7 gobos + open<br>& gobo shake<br>effect | <br>Strobe         | <br>Omega<br>fixations    | <br>Easy 2               |
| <br>1 IEC IN/OUT<br>240V - 50Hz<br>plug      | <br>155 W          | <br>292x185x461<br>mm     | <br>8 kg                 |



**FLY2CLUB-S1**

For Typhoon/Thunder/Cyclone/Wave/Hezo120Z

ref 10247



# CYCLONE 120R

120W LED multi-effects spot moving head

**One of the very best device in its category**

ref 10402

- + Large beamwidth
- + 120 W LED
- + Colour wheel with 8 colours + open
- + Gobo wheel with 6 rotating gobos + open
- + 3-facet rotating prism
- + Electronic strobe
- + Fast and smooth movements



The very popular CYCLONE-80 has evolved.

The CYCLONE-120R is the same size, same features, plus the new gobo rotation and 120W LED. This new spot moving head delivers more power and features more effects while preserving the CYCLONE-80 high-quality and movement speed.

And of course, we kept the now famous dancefloor-focused programming and stage functions.

These evolutions coupled with the outstanding performance of the CYCLONE-80 make of the CYCLONE-120R one of the very best device in its category in terms of performance and options.



## FLY2CLUB-S1

For Typhoon/Thunder/Cyclone/Wave/Hezo120Z

ref 10247



### TECHNICAL SPECIFICATIONS:

- |                         |                       |                        |   |                                |
|-------------------------|-----------------------|------------------------|---|--------------------------------|
| LED<br>1 x 120 W CW LED | Beamwidth<br>15°      | DMX<br>1 - 16 channels | Auto  | Music-sensitive                |
| Master/Slave            | Pan 540°<br>Tilt 270° | 8 colours + open       | 6 rotating gobos + open & gobo shake effect | Rotating prism                 |
| Strobe                  | Manual focus          | Omega System           | Easy 2                                      | IEC IN/OUT plug<br>240V - 50Hz |
| 200 W                   | 292 x 169 x 425 mm    | 8 kg                   |   |                                |

# CYCLONE 80

80W LED multi-effects spot moving head

**What every club needs**

ref 10175

The CYCLONE-80 is super-powerful. Its 80W LED outperforms any halogen lamp in terms of brightness, durability and visual comfort. The 3-facet rotating prism, electronic strobe, gobo and colour wheels are as many features you will need to create shows you will never forget.

- + Large and bright output
- + Rotating gobos and colour wheels
- + Fast and sharp movements

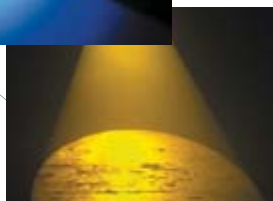



















## FLY2CLUB-S1

For Typhoon/Thunder/Cyclone/Wave/Hezo120R

ref 10247



### TECHNICAL SPECIFICATIONS :

- |  |   |   |   |  |
|--|---|---|---|--|
|  <b>LED</b><br>1x80W CW LED |  <b>15° aperture</b>           |  <b>DMX</b><br>1 - 15 channels |  <b>Auto</b>                                   |  <b>Music-sensitive</b>                   |
|  <b>Master/Slave</b>        |  <b>Pan 540°<br/>Tilt 270°</b> |  <b>8 colours + white</b>      |  <b>7 gobos + open &amp; gobo shake effect</b> |  <b>Rotating prism</b>                    |
|  <b>Strobe</b>              |  <b>Manual focus</b>           |  <b>Omega fixations</b>        |  <b>Easy 2</b>                                 |  <b>1 IEC IN/OUT<br/>240V - 50Hz plug</b> |
|  <b>150 W</b>               |  <b>292 x 169 x 425 mm</b>     |  <b>8 kg</b>                   |   |  |

# BLAST 60

60W LED spot moving head

**A major lighting performer**







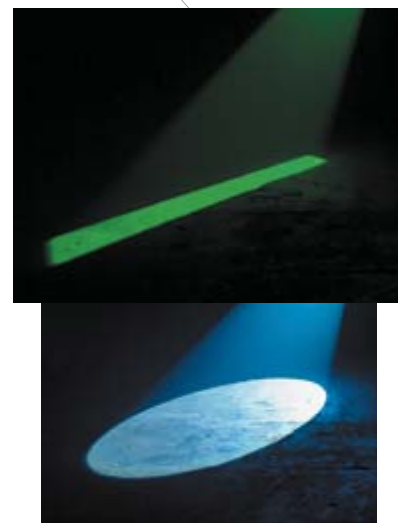









ref 10312

The BLAST-60 is the essence of high-technology ultra-compact projectors. Its 60 Watts LED and its high-performance optical system make it one of the very best in its category. It is small, but we equipped it with many, many features: a rotating gobo wheel, a colour wheel, a stroboscope, an electronic dimmer, and dance floor-focused built-in programs. The BLAST-60 is absolutely exquisite when it comes to clubs and small live venues.

- + High-definition optical system and a 60W LED
- + 1 gobo wheel with 8 rotating gobos
- + 1 colour wheel with 8 colours
- + Built-in music-sensitive programs



## TECHNICAL SPECIFICATIONS :

- |  |   |   |   |  |   |
|--|---|---|---|--|---|
| <br>1x60W LED                               | <br>14° aperture angle | <br>1-8-12 channels                          | <br>Auto   | <br>Music-sensitive | <br>Master/Slave |
| <br>Pan 540°<br>Tilt 270°                   | <br>8 colours + open   | <br>6 rotating colours + open and gobo shake | <br>Strobe | <br>Omega fixation  | <br>Easy 2       |
| <br>240V - 50 Hz<br>IEC IN/OUT power socket | <br>70 W               | <br>212 x 174 x 352 mm                       | <br>5.3 kg |  |   |

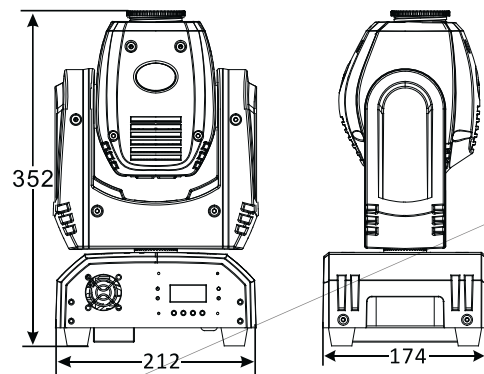



# NOUVELLE HEZ0300ZR

Angle maximum, effet ring  
la force est avec elle\*

\*Maximum angle, ring effect  
\*May the force be with it



by **Contest**<sup>®</sup>



# HEZO 300ZR

Moving head with 19 x 15W 4-in-1 RGBW LEDs and Zoom

**Ring function and super zoom**

ref 10710



Zoom



3 Zone control



Exclusive lens Focus Zoom HD



FLICKER FREE



## CRYSTAL LIGHT PIPE

The « Crystal Light Pipe » system allows to channel as much light as possible from each LED.

This technical process aims to concentrate and channel the entire light output of each LED towards the main lens. This process is flexible and can achieve perfect colour mixing and rendering either at 10° or 60°.



## FLY2HEZO300ZR

Flight case for 4x HEZO300Z

ref 10736

## WASH !

It features Osram® 15W 4-in-1 LEDs. Combined with a next-gen optical system, they deliver a very powerful light output, optimised for colour mixing.

With more than 9030 lux at 5 meters over an angle from 10° to 60°, this is the perfect tool for stage lighting and maximum possibilities.

Its 3 customisable zones, from the center to the outer ring, allow the HEZO300ZR to be a dynamic, powerful “wash” projector.

- + Customisable zones (Ring)
- + Super ZOOM
- + Powerful “wash” projector
- + Perfect colour mixing



## TECHNICAL SPECIFICATIONS :



19x15W LEDs  
Osram® QC



Beamwidth  
10° to 60°  
with motorized zoom



1-22 /30  
channels



Auto



Music



Master/Slave



Pan 540°  
Tilt 270°



Strobe



1/4 tour  
Omega



325 x 222  
x 393 mm



9kg



Socket IEC IN/OUT  
powerCON



340 W





# HEZO 120Z

12 x 10 W RGBW OSRAM® LEDs wash moving head  
**Power, Focus and infinite colours**  
 ref 10408



Zoom

Exclusive lens  
Focus Zoom HD

RGBW  
LEDs

- + Incredible color rendering
- + Linear zoom from 10° to 60°
- + Fast, compact and light moving head
- + New optical system with HD focus zoom

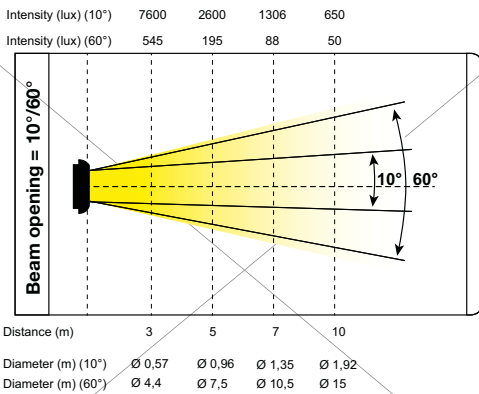

## FLY2CLUB-S1

For Typhoon/Thunder/Cyclone/Wave/Hezo120Z  
 ref 10247



## FLY-RAY1R-HEZO120ZX4

For 4x Hezo120R  
 code 10610

This flight case has been specifically designed to safely transport four of your HEZO120Z projectors and all their accessories.

### TECHNICAL SPECIFICATIONS:

- LED**  
12 x 10 W OSRAM® LEDs
- Beamwidth**  
10 to 60°
- DMX**  
1 - 17 channels
- Auto**
- Music-sensitive**
- Master/Slave**
- Pan 540°  
Tilt 240°**
- 14 x Le Club compatible colours**
- Strobe**
- Omega Fixation**
- powerCON IN/OUT**  
240V - 50Hz
- 198 W**
- 340 x 269 x 183 mm**
- 7,5 kg**

# HEZ0120Z

Les experts en couleurs et lumière  
reconnaîtront son talent\*

\*Colour experts will acknowledge its talent





# MINI-HEAD10W

Ultra-compact 10 W LED moving head with 7 colours and 8 gobos  
ref 10289

- + LED Technology
- + Ultra-compact
- + Super-fast movement speed
- + 7 dichroic colors + 7 gobos



26 cm

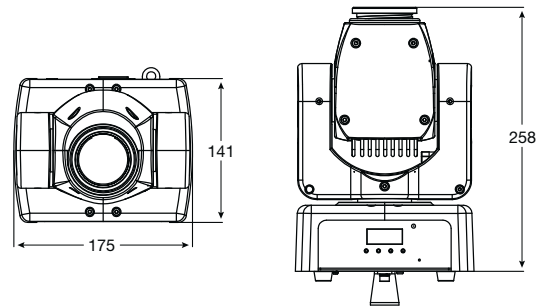
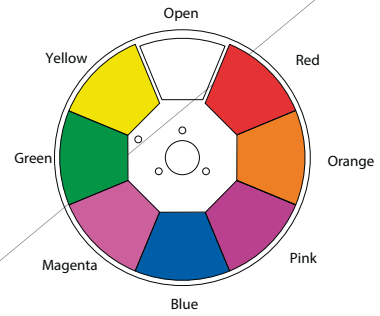
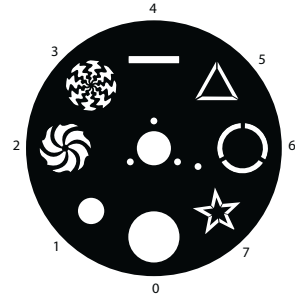

## TECHNICAL SPECIFICATIONS :

- |                     |                  |                         |                               |                |                 |                       |                |
|---------------------|------------------|-------------------------|-------------------------------|----------------|-----------------|-----------------------|----------------|
| LED<br>1 LED 10W CW | Beamwidth<br>14° | DMX<br>1 to 10 channels | Auto                          | Sound to light | Master/Slave    | PAN 610°<br>TILT 220° | Omega fixation |
| 7 Colours + white   | 7 gobos + open   | Strobe                  | IEC IN socket<br>240V - 50 Hz | 20 W           | 258 x175x141 mm | 2,7 kg                |                |

# LIGHT PRO

# NOUVELLE FUSION180

La lyre hybride 3 en 1\*

\*3-in-1 hybrid moving head





# FUSION 180

The hybrid moving head by Contest®  
ref 10661



- + 3-in-1 beam, spot, wash
- + Powerful LED source
- + 6-facet linear prism
- + 8-facet linear prism
- + Linear transition from beam to spot

### 3-IN-1 HYBRID MOVING HEAD

Fusion180 is a 3-in-1 hybrid moving head. Its next-gen optical system allows it to produce BEAM, SPOT or WASH effects. Its motorized focus and long-range linear zoom bring it maximum flexibility and an optimal projection quality, regardless of the mode used.

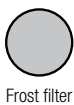

### A LARGE SCALE OF EFFECTS

You can now shape your beam endlessly with the rotating 8-facet circular prism or 6-facet linear prism.

Last but not least, Fusion180 features one wheel with 15 fixed including 3 filters, one wheel with 9 rotating gobos and one colour wheel with 10 colours + open.

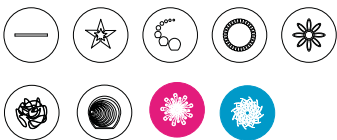
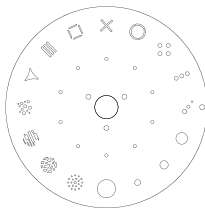
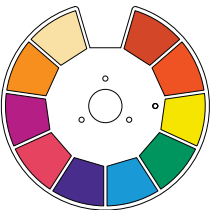

Contest®   
FUSION180

024



**IT WILL ANSWER YOUR EVERY NEED THANKS TO ITS FLEXIBILITY.**

Fusion180 was built around a 180W LED source, and delivers a powerful output, increased by a range allowing you to switch in a linear fashion from a narrow 6° beam to a wider 21° spot-like beam.

The Wash mode unlocks a whole new range from 34° to 60°.



**FLY2Fusion180**

Flight case for 2x Fusion180

ref 10737



**TECHNICAL SPECIFICATIONS**

**LIGHT SOURCE**

- LED 180W

**COLOURS, GOBOS AND EFFECTS**

- 1 wheel with 10 dichroic colours and rainbow effect
- 1 wheel with 9 interchangeable and indexable rotating gobos with gobo shake effect
- 1 wheel with 12 fixed gobos + 3 beam filters with gobo shake effect
- 8-facet circular and rotating prism
- 6-facet linear and rotating prism
- Progressive Frost filter allowing wash effects
- Linear zoom from 6 - 21° allowing you to switch from beam mode to spot mode with full transparency
- Wash function from 34° - 60°
- Adjustable strobe from 1-25 flashes per second and random strobe
- Electronic dimmer from 0 - 100% with 4 dimming curves

- 16-bit motorized focus

**Controls**

- Standard DMX-512
- 17, 19 or 20 DMX channels (3 modes : Basic, Standard or Expert)
- Assignable patch for all DMX channels
- 9 built-in programs accessible via the DMX menu
- Built-in music-sensitive programs
- Automatic detection of DMX or Master / Slave mode
- Colour LCD drop-down display to assign and select modes
- Battery-operated memory setting to address and select mode without 230V power supply unit
- RDM-Compatible for console feedbacks

**MOVEMENTS**

- 8 and 16-bit Pan and Tilt resolution
- Range: Pan 540° or 630° - Tilt 270°

**Optical**

- Beamwidth from 6° - 21° via motorized zoom

**LIGHT OUTPUT:**

- 33000 LUX at 5m with a 6° angle
- 2180 LUX at 5m with a 24° angle

**CONNECTIONS:**

- DMX IN and OUT via 3 and 5-pin XLR sockets,
- POWER IN/OUT via powerCON sockets

**PACKAGE CONTENT**

- The moving head
- The user guide
- One Powercon® / 2 poles + earth cord
- 2 quicklock/Omega

**ADDITIONAL CHARACTERISTICS**

- Power consumption: 305W max.
- Power supply: 100/240V, AC - 50/60Hz
- Dimensions: 369x288x583 mm
- Net weight: 18 Kg

# EVORA FLEX

Quand précision rime avec couleurs\*

\*EVORA FLEX: Where precision and colours meld



by **Contest**<sup>®</sup>



# EVORA FLEX15R

Spot moving head with a Philips® MSD PLATINUM 15R lamp

**Flexibility meets power**

ref 10295



- + Supplied with a Philips® MSD PLATINUM 15R lamp
- + Trichromy using Cyan, Magenta, and Yellow dichroic filters
- + x4 motorised zoom
- + Double gobo wheel
- + Colour wheel with 6 extra colours
- + 3-facet rotating prism and frost filter
- + Iris



Its optical system was built around the new Philips MSD PLATINUM15R lamp and generates a high-precision incredibly bright light output.

With 17,000 lux at 7 metres, the EVORA-FLEX15R is one of the most complete moving head in the world.

The EVORA-FLEX15R benefits from the latest technological breakthroughs: the super-fast zoom, the iris and the frost filter allow you to switch from a beam to a wash effect in the blink of an eye. Shape the light beam with the fixed and rotating gobo wheels and the 3-facet rotating prism.

There is more: Evora FLEX is equipped with a trichromatic (CMY) mixing system in addition to a 6-colour wheel, allowing you to create a gigantic colour palette.

## FLY-FLEX15-SWORD5Rx2

Flight-case for 2 Evora-Flex15R

ref 10343

Our flight case has been specially designed to safely transport 2 EVORA-FLEX15R moving heads and all their features.





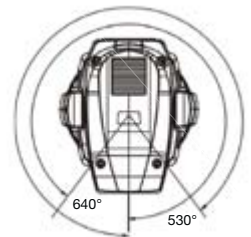
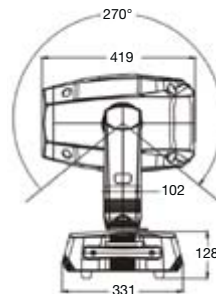
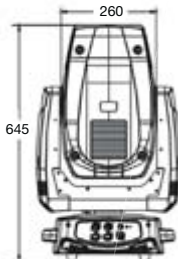
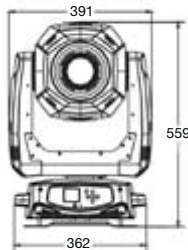
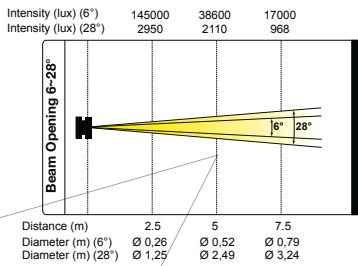
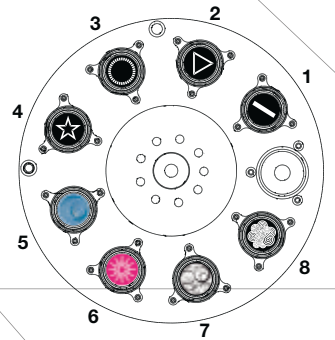
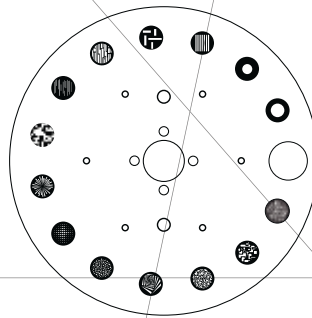
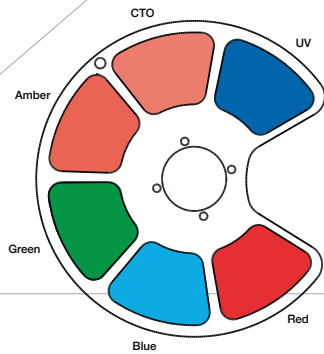
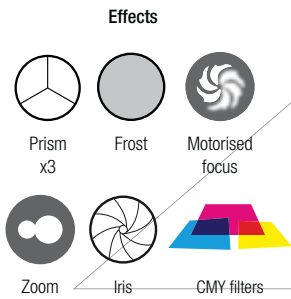

## TECHNICAL SPECIFICATIONS

### LIGHT SOURCE

- Philips® MSD PLATINUM 15R Lamp - 8000°K
- Lifespan limited to 2000 hours for safety reasons
- Power consumption : 300W

### COLOURS, GOBOS AND EFFECTS

- 3 Cyan, Magenta and Yellow filters for trichromatic colour mixes
- 1 colour wheel with 6 dichroic colours and rainbow effect
- 1 gobo wheel with 8 indexable and rotating gobos and gobo shake effect
- 1 gobo wheel with 14 fixed gobos and gobo shake effect
- 3-facet rotating prism with 16 macros
- 1 -13 flashes per second strobe and random strobe
- Adjustable iris: 5 - 100%
- Adjustable dimmer: 0-100%
- Adjustable frost filter: 0 - 100%
- Adjustable focus: 0 - 100%
- Adjustable zoom: 6 - 28°

### CONTROL

- Standard DMX-512
- 21, 23 or 34 DMX channels (3 modes : Basic, Standard or Expert)
- Assignable patch to every channel
- 7 built-in programs accessible from the DMX
- Built-in musical programs
- Automatic detection of the DMX, slave or master mode
- Colour LCD drop-down menu to choose and assign the different modes
- Battery-operated memory system to address and choose modes without the 230V power supply
- Compatible with RDM for console feedbacks

### MOVEMENTS

- 8 or 16 bits Pan and Tilt resolutions
- Ranges : Pan 540 or 630° - Tilt 270°

### OPTICAL

- Beamwidth: 6° to 28°
- Light output: 38600 LUX at 5m with a 6° aperture

### ADDITIONAL CHARACTERISTICS

- Power consumption : 400W max.
- Power supply: AC 100/240V - 50/60Hz
- Net weight: 19 Kg

### PACKAGE CONTENTS

- The Evora-Flex15R moving head and its lamp
- The user guide
- Bracket with quick lock system & Omega
- 1 safety chain
- 1 DMX cable
- 1x2-pole + earth power cord / powerCON socket

# GAMME INFINITY

La technologie infinity sur orbite\*

\*The infinity technology sent into orbit





# INFINITY TECHNOLOGY SERIES



## “INFINITY”

FLAG25i and ROTOR7i are the two new LIGHT pro series projectors equipped with the “Infinity” technology, allowing you to get rid of movement restrictions thanks to the non-stop 360° rotation.



## HIGH-END OPTICAL SYSTEM

Its 4° optics coupled to 15W 4-colour LEDs allow you to produce well-defined beams precisely separated from each other.

## 360° AND 3D GRAPHIC AND VOLUMETRIC EFFECT

Both FLAG25i and ROTOR7i feature LEDs which can be controlled individually to create breathtaking 3D graphic and volumetric effects.



## ADVANCED CONTROL

FLAG35i & ROTOR7i can be controlled pixel by pixel via the DMX512, Art-Net™ or Kling net protocols.



# FLAG 25i

Moving head with 25 x 15W 4-in-1 LEDs

**Unlimited creativity**

ref 10406

- + Control your 5x5 panel pixel by pixel
- + Non-stop PAN and TILT rotation
- + 15W RGBW LEDs
- + Beamwidth: 4° for each beam
- + DMX, Art-net and Kling net protocols
- + 63mm optical collimator
- + New Random strobe and Random pulse per pixel modes



TECHNOLOGY  
INFINITY



FLAG25i is the first PANEL projector from our LIGHT PRO series equipped with the "Infinity" technology, allowing limitless PAN and TILT movements.

Its 25 beams can be controlled individually to create graphic animations such as numbers, letters but also 3D volumetric animations at 360°. The only limit is your imagination.

Its 25 x 15W RGBW LEDs have been associated with high-quality 63mm collimator allowing a powerful light output of almost 30.000 Lux at 5 m (at full power).

FLAG25i can be controlled pixel by pixel via the DMX512, Art-Net™ or Kling net protocols.

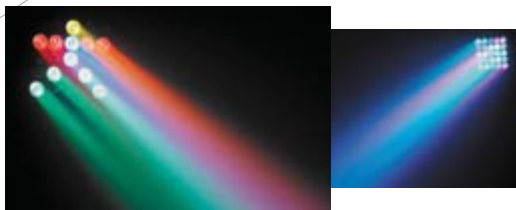

Intensity (lux) 77344 70370 54413 40505 29722

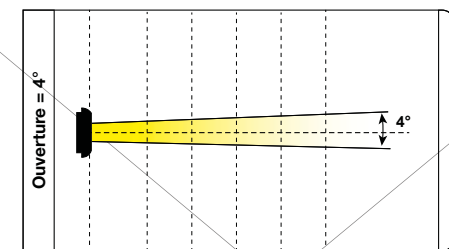

Distance (m) 1 2 3 4 5  
Diameter (m) (4°) Ø 0,06 Ø 0,15 Ø 0,24 Ø 0,32 Ø 0,40

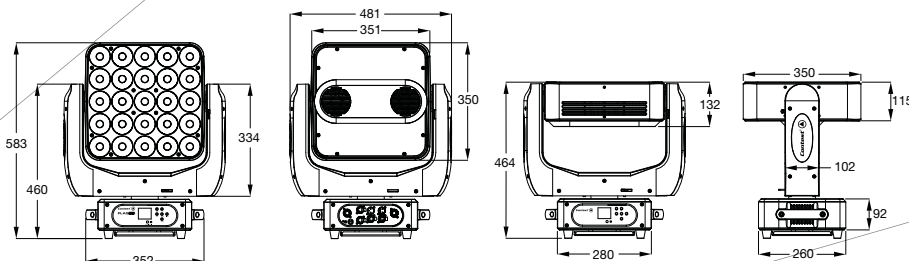

## TECHNICAL SPECIFICATIONS

### LIGHT SOURCE

- 25 x 15 W LEDs
- 4-in-1: Red, Green, Blue and White within the same source
- Expected lifespan of 50.000 hours
- Low temperature, low power consumption, can be operated non-stop for many hours

### COLOURS

- Colour macros
- Colour presets

### EFFECTS

- Patterns with letters, numbers with customizable colours
- Automatic or music-sensitive programs
- Adjustable strobe and random strobe
- Electronic dimmer: from 0 - 100%

### CONTROL

- 16,21 and 117 DMX channels
- Ethernet port for Art-NET and KlingNET™ command protocols
- Built-in musical programs accessible and customizable from the DMX menu
- LCD drop-down display to assign and choose different modes
- Battery-operated memory system to address and choose modes without the 230V power supply
- Compatible with RDM for console feedbacks

### MOVEMENTS

- Regular 8 or 16-bit Pan and Tilt resolutions restricted to 630° and 270°
- Non-stop Pan and Tilt rotation
- Use the menu or DMX to adjust speed
- Position memory and auto-repositioning

### OPTICAL SYSTEM

- Beamwidth of each lens: 4°
- Light output: 29700 Lux at 5m

### ADDITIONAL CHARACTERISTICS

- IN/OUT powerCON sockets
- IN/OUT 3 and 5-pin DMX sockets
- IN/OUT RJ45 Ethernet sockets
- Power consumption: 420 W max.
- Power supply: 100/240V, AC - 50/60Hz
- Net weight: 18.6 kg

### PACKAGE CONTENTS

- The moving head
- Quicklock/Omega fixation system
- The user guide
- 1 x 2 poles + earth power cord / powerCON

## FLY2FLAG25

Flight case designed for 2 FLAG25i

ref 10428

This flight case has been specifically designed to safely transport two of your FLAG25i projectors and all their accessories.





# ROTOR 7i

7 x 15W 4-in-1 LEDs motorized bar

**A new type of linear projector**

ref 10407

ROTOR7i is the first linear projector from our LIGHT PRO series equipped with the "Infinity" technology, allowing limitless PAN and TILT movements.

The very special alignment of 7 sources is what makes this projector so unique. It allows you to create columns of light and tons of new effects thanks to individual control and 360° movements. Its compact size is perfect to fit any installation, any position and create the perfect effect.

Its 7 x 15W RGBW LEDs have been associated with high-quality 63mm collimator allowing a surprising light output of almost 8.000 Lux at 5 m (at full power).



- + Pixel by pixel control
- + Non-stop PAN and TILT rotation
- + 15W RGBW LEDs
- + Beamwidth: 4° for each beam
- + DMX, Art-net and Kling net protocols
- + 63mm optical collimator
- + New Random strobe and Random pulse per pixel modes

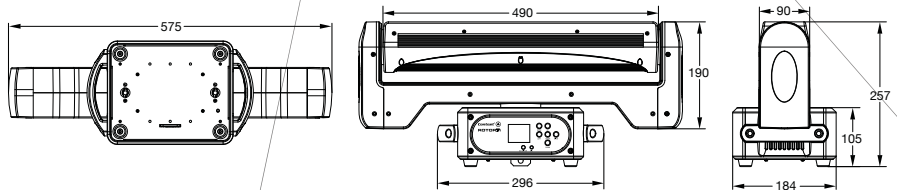
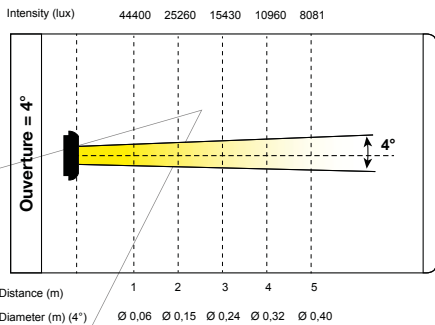

## TECHNICAL SPECIFICATIONS

### LIGHT SOURCE

- 7 x 15 W LEDs
- 4-in-1: Red, Green, Blue and White within the same source
- Expected lifespan of 50.000 hours
- Low temperature, low power consumption, can be operated non-stop for many hours

### COLOURS

- Colour macros
- Colour presets

### EFFECTS

- Automatic or music-sensitive programs
- Adjustable strobe and random strobe
- Electronic dimmer: from 0 - 100%

### CONTROL

- 15,20 and 44 DMX channels
- Ethernet port for Art-NET and KlingNET™ command protocols
- Built-in musical programs accessible and customizable from the DMX menu
- LCD drop-down display to assign and choose different modes
- Battery-operated memory system to address and choose modes without the 230V power supply
- Compatible with RDM for console feedbacks

### MOVEMENTS

- Regular 8 or 16-bit Pan and Tilt resolutions restricted to 630° and 270°
- Non-stop Pan and Tilt rotation
- Use the menu or DMX to adjust speed
- Position memory and auto-repositioning

### OPTICAL SYSTEM

- Beamwidth of each lens: 4°
- Light output: 8100 Lux at 5m

### ADDITIONAL CHARACTERISTICS

- IN/OUT powerCON sockets
- IN/OUT 3 and 5-pin DMX sockets
- IN/OUT RJ45 Ethernet sockets
- Power consumption: 133 W max.
- Power supply: AC 100/240V - 50/60Hz
- Net weight: 9,6 kg

### PACKAGE CONTENTS

- The moving head
- Quicklock/Omega fixation system
- The user guide
- 1 x 2 poles + earth power cord / powerCON

## FLY2ROTOR7i

Flight-case pour 2 ROTOR7i

ref 10429

This flight case has been specifically designed to safety transport two of your ROTOR7i projectors and all their accessoires



# DART60i



60W moving head with non-stop PAN and TILT rotation

**Design | Power | Versatility**

code 10490



TECHNOLOGY  
INFINITY

## INCREDIBLE MOVEMENTS

Like any other product from the « Infinity » series, this projector features the non-stop PAN and TILT rotation.

DART60i offers remarkably dynamic effects thanks to extremely fast and precise movements. Slow travellings, music-sensitive pans and swift movements: it gets the most out of every feature you need.

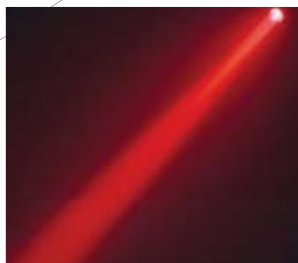

## THE COB POWER

The 60W 4-in-1 COB LED (red, green, blue and white) within the same source coupled with a high-quality 90mm collimator allows a tremendous light output of 14 570 LUX at 3 metres.

Its top-of-the-range optical system focuses beams and uses efficiently the 60W source to create straight, long range beams.

Moreover, its compact housing and rounded curves allow you to set up several projectors in a small area to create as many configurations as you want. Perfect for cramped areas.



# FLY-DARTX6

Flight case for 6 DART60i  
ref 10611

Its incredible light output is one thing, but it also allows you to mix RGBW colours thanks to the COB technology and diffuser filters for even more versatility.

Not the least, DART60i can also be controlled via DMX512 via its built-in programs for a simplified yet very complete use.



## SHAPE THE LIGHT

DART60i offers 3 different angles, thanks to the supplied set of accessories :

- Original lens delivering a tight 4° "BEAM" effect
- A wider 10° beam thanks to the "FLOOD" filter
- 45° lens with frost filter to create an amazing "WASH" effect



Lens only  
4° Beam effect



Lens with Flood filter  
10° beam



Lens with 45°  
Wash filter

## LIGHT SOURCE

1x 60W 4-in-1 COB LED

4-in-1: Red, Green, Blue and White within the same source

## COLOURS

Colour macros

«Effects» colour presets

Automatic or music-sensitive programs

Adjustable strobe and random strobe

Adjustable electronic dimmer from 0 – 100%

## CONTROL

12, 17, 19 DMX channels

Access and personalize the built-in musical programs from the DMX menu

LCD display with drop-down menu for assignation and mode selection

Battery-operated memory settings to address and select modes without the 230V power supply unit

## MOVEMENTS

8 and 16-bit PAN and TILT resolutions

Non-stop PAN and TILT rotation

Adjustable speed from the menu and DMX

Position memory and auto-repositioning

## OPTICAL

Lens angle 4°

Light output 5280 Lux at 5m

Frost filter at 10° to create flood effects

Frost filter at 45° to create wash effects

## ADDITION CHARACTERISTICS

IN/OUT powerCON sockets

3 and 5-pin IN/OUT DMX sockets

Power consumption: 80 W max.

Power supply: 100/240V, AC - 50/60Hz

Net weight: 5,3 kg

Quicklock/Omega fastening system

1 x 2-pole + earth power cord / powerCON

# DART90iZOOM



90W moving head with non-stop rotation and zoom

**Design | Power | Zoom**

code 10594



TECHNOLOGY  
INFINITY

## INCREDIBLE MOVEMENTS

Like any other product from the « Infinity » series, this projector features the non-stop PAN and TILT rotation.

DART90iZOOM offers remarkably dynamic effects thanks to extremely fast and precise movements. Slow travellings, music-sensitive pans and swift movements: it gets the most out of every feature you need.



## THE COB POWER

This new 90W 4-in-1 (RGBW) LED within a « COB » housing, plus the new 90mm optical collimator allow DART90iZOOM to project an enormous light output of 10 620 LUX at 3 metres over a 4° angle.



DART90iZOOM is the evolution of DART60i, thanks to its 90W source and adjustable angle brought by its linear zoom. d'encombrement.

Contest® 

DART  
90iZOOM





**ART-NET**

DART90iZOOM can be controlled via DMX512 or Art-NET and features built-in programs for an easy, yet very complete use



**ART  
NET**  
CONTROL



**PLUS A ZOOM**

The optical collimator of DART90iZOOM combined with a linear zoom allows you to switch from a 4° (beam) angle directly to a 44° (wash) angle in the blink of an eye.



**FLY-DARTX6**

Flight case for 6x DART90iZOOM  
ref 10611



**LIGHT SOURCE**

1 x 90W 4-in-1 COB LED  
4 colours in 1 Red, Green, Blue and White within the same source

**COLOURS**

Colour macros  
«Effects» colour presets  
Automatic or music-sensitive programs  
Adjustable or random strobe  
Adjustable electronic dimmer from 0 to 100%

**CONTROL**

13, 18, 20 DMX channels  
Ethernet port for Art-NET command protocol  
Access and personalize the built-in musical programs from the DMX menu  
LCD display with drop-down menu for assignation and mode selection  
Battery-operated memory settings to address and select modes without the 230V power supply unit

**MOVEMENTS**

8 and 16-bit PAN and TILT resolutions  
Non-stop PAN and TILT rotation  
Adjustable speed from the menu and DMX  
Position memory and auto-repositioning

**ADDITIONAL CHARACTERISTICS**

IN/OUT powerCON sockets  
3-pin IN/OUT DMX sockets  
Ethernet IN/OUT via RJ45 socket  
Power consumption 120 W max.  
Power supply 100/240V, AC - 50/60Hz  
Net weight 5,3 kg  
Quicklock/Omega fastening system  
11 x 2-pole + earth power cord / powerCON

**OPTICAL**

Zoom range 4° - 44°  
Light output 3800 Lux at 5 m

# PIN15QC

Beam projectors with 4-in-1 15W LEDs

**4° | 10° | 45°**

ref 10595



- + 15W RGBW COB LED
- + 4° Optical collimator
- + 10° and 45° lenses
- + Compact dimensions
- + Infrared remote control

PIN15QC is equipped with the same 15W RGBW COB LED we already used for our ROTOR7i, FLAG25i and RADIUS15. This source, coupled with the same optical collimator allows a 4° beam, which can be extended to 10° or 45° thanks to optional lenses.

PIN15QC is perfect for both installations and periodic use via its remote control giving you access to every function.



|                                       |                          |
|---------------------------------------|--------------------------|
| 1 x LED                               | 15W RGBW                 |
| Angles                                | 4°   10°   45°           |
| Power consumption                     | 17 W                     |
| Alimentation                          | 100V-240V, AC, 60Hz-50Hz |
| IEC IN/OUT                            |                          |
| 3-pin DMX IN/OUT                      |                          |
| Automatic or music-sensitive programs |                          |
| DMX control                           | 1,4,7,12 channels        |
| Infrared remote control               |                          |
| Dimensions                            | 135 x 203 x 172 mm       |
| Net weight                            | 1,4 kgs                  |

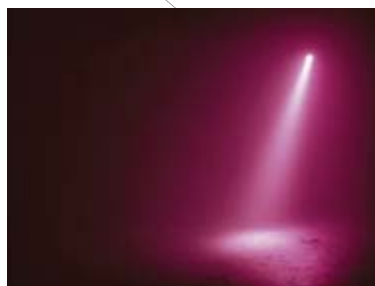

# PIN15W

Beam projectors with 4-in-1 15W warm white LEDs  
**4° | 10° | 45°**  
 ref 10709



- + 15W COB LED WW
- + 4° Optical collimator
- + 10° and 45° lenses
- + Compact dimensions
- + Infrared remote control

**NEW**



|                                       |  |
|---------------------------------------|--|
| 1 x LED                               | 15W warm white                         |
| Angles                                | 4°   10°   45°                         |
| Power output                          | 3280/1500/215 Lux pour 4°/10°/45° @ 4m |
| Power consumption                     | 17 W                                   |
| Alimentation                          | 100V-240V, AC. 60Hz-50Hz               |
| IEC IN/OUT                            |  |
| 3-pin DMX IN/OUT                      |  |
| Automatic or music-sensitive programs |  |
| DMX control                           | 1,2 channels                           |
| Infrared remote control               |  |
| Dimensions                            | 135 x 203 x 172 mm                     |
| Net weight                            | 1,4 kgs                                |



# NINJA 7i

La rotation infinie à très grande vitesse\*

\*High-speed infinite rotation



by **Contest**<sup>®</sup>





# NINJA 7i

7 x 15W 4-in-1 LEDs moving head  
**NINJA à l'infini**  
 ref 10405



- + Incredible light output
- + Non-stop PAN & TILT
- + 7 x 15 Watts 4-in-1 OSRAM® LEDs



### INFINITE ROTATION

Discover a new way of thinking about lighting. We kept the projection quality, precision and speed of our NINJA 7x15QC and added a 360° non-stop rotation to create the NINJA7i. This moving head will add an incredible dynamism and spectacular movement effects to your shows.

### EVEN MORE BRIGHTNESS

The NINJA7i moving head is fully equipped with the brand new 15 Watts OSRAM® LEDs, renowned for their brightness and consistency. They deliver an incredible light output thanks to high quality individual lenses. The NINJA7i moving head also allows you to create unprecedented colour effects by controlling separately the ring and the center

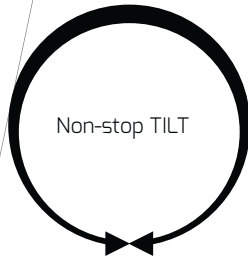

Our Ninja7i is equipped with the "Infinity" technology allowing limitless PAN and TILT rotations. Its powerful motors make it the fastest moving head with non-stop rotation.

|                     |       |       |      |
|---------------------|-------|-------|------|
| Intensity 11° (lux) | 25500 | 11890 | 4410 |
| Intensity 20° (lux) | 5120  | 2369  | 863  |

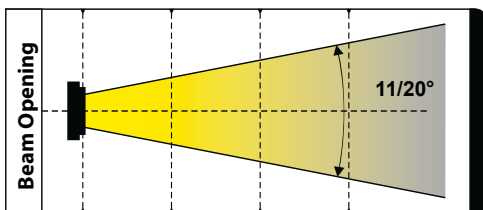

|                  |        |        |        |
|------------------|--------|--------|--------|
| Distance (m)     | 2      | 3      | 5      |
| Diameter 11° (m) | Ø 0,38 | Ø 0,57 | Ø 0,96 |
| Diameter 20° (m) | Ø 0,70 | Ø 1,05 | Ø 1,76 |



## FLY4NINJA-S1

Flight case designed for 4 Ninja7i  
 ref 10076

This flight case has been specifically designed to safely transport 4 of your Ninja projectors and all their accessories.

# NINJA 7x15QC

Quadricolore moving beam with seven 15W LEDs  
**Unprecedented power and speed**  
 ref 10075

Its incredible movement speed and light output lead us to think the Ninja moving head will revolutionise the lighting business.

- + A tremendous light output
- + Extremely fast movements
- + 7x15 Watts OSRAM® quadricolour LEDs

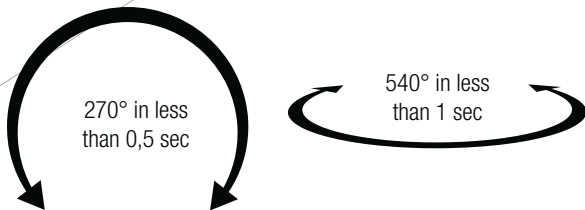

## STUNNING MOVEMENTS

It shines at all kind of movements: Sweeping in rhythm, swift movements, slow tracking shots and more. The Ninja-7x15QC moving head will give an incredible dynamism to your shows thanks to its extremely fast and precise movements. Enter a new conception of lighting.



## FLY4NINJA-S1

4 Ninja-7x15QC moving head flight case  
 ref 10076

This flight case has been specially designed for 4 Ninja-7x15QC moving heads and all their features allowing you to transport them safely.



|                     |       |       |      |
|---------------------|-------|-------|------|
| Intensity 11° (lux) | 25500 | 11890 | 4410 |
| Intensity 20° (lux) | 5120  | 2369  | 863  |

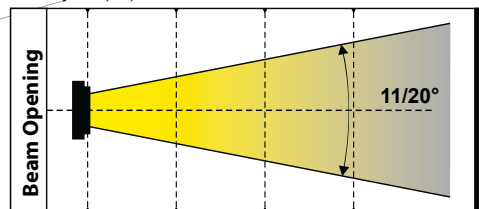

|                  |        |        |        |
|------------------|--------|--------|--------|
| Distance (m)     | 2      | 3      | 5      |
| Diameter 11° (m) | Ø 0,38 | Ø 0,57 | Ø 0,96 |
| Diameter 20° (m) | Ø 0,70 | Ø 1,05 | Ø 1,76 |

## EVEN MORE BRIGHTNESS

The Ninja-7x15QC moving head is fully equipped with the brand new 15 Watts OSRAM® LEDs, renowned for their brightness and consistency. They deliver an incredible light output thanks to high quality individual lenses. The Ninja-7x15QC moving head also allows you to create unprecedented colour effects by controlling separately the ring and the center.

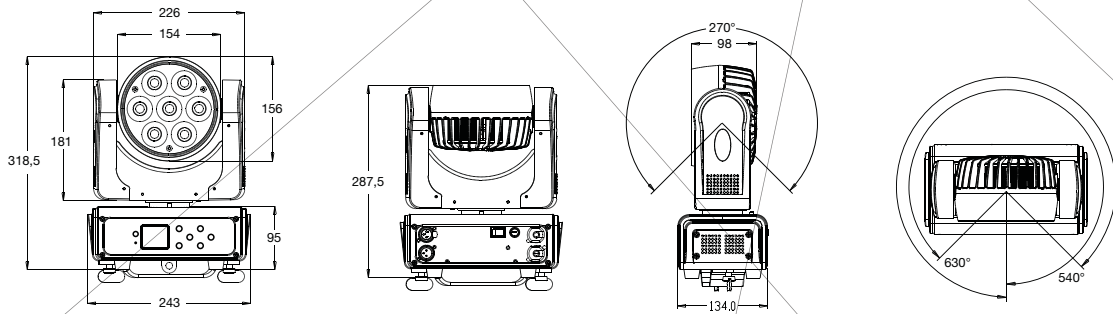
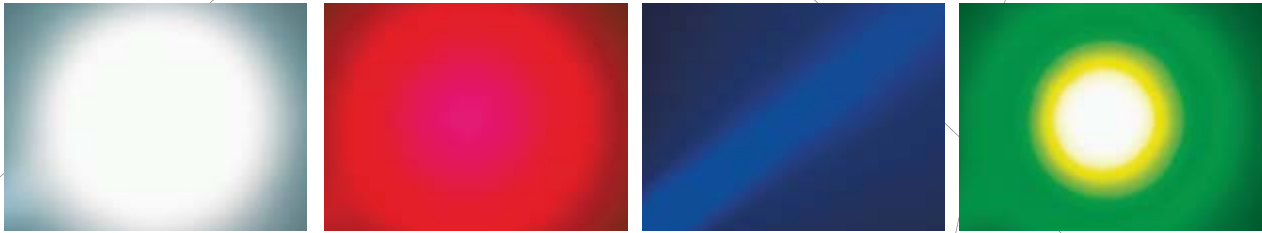

### 3 APERTURE ANGLES FOR A MAXIMUM ADAPTABILITY

The Ninja-7x15QC and Ninja7i opens at 11° and is delivered with two accessories allowing you to control the beam and its aperture angle:

- The Frost filter is a flow diffuser with a wash effect and a 20° aperture
- The Spoiler concentrates the light flow to create a beam effect on a 9° angle (not compatible on Ninja7i)

### TECHNICAL SPECIFICATIONS

#### SOURCE LUMINEUSE

- 7x15W OSRAM LEDs
- 4-in-1: Red, Green, Blue, and White within the same source
- Expected lifespan of 50.000 hours
- Low temperature, low power consumption, can be operated non-stop for many hours

#### COLOURS

The ring and the center both have independent settings

- Colour macros
- Colour presets

#### EFFECTS

- Adjustable strobe: 1-18 flashes per second and random strobe
- Adjustable electronic dimmer: 0-100%

#### CONTROL

- Standard DMX-512
- 15 to 21 DMX channels (Ninja-7x15QC)
- 16 to 25 DMX channels (Ninja7i)
- Assignable patch to every channel
- 7 built-in programs accessible from the DMX and customisable
- Built-in musical programs
- Automatic detection of the DMX, slave or master mode
- Colour LCD drop-down menu to choose and assign the different modes
- Battery-operated memory system to address and choose modes without the 230V power supply
- Compatible with RDM for console feedbacks

#### MOVEMENTS

- Regular 8 or 16-bit Pan and Tilt resolutions restricted to 630° and 270°
- Infinite movement allowing a non-stop Pan and Tilt rotation (Ninja7i)
- Adjustable speed via the DMX
- Position memory and auto-repositioning

#### OPTICAL SYSTEM

- Beamwidth: 10°
- Light output: 4400 Lux at 5m

#### ADDITIONAL CHARACTERISTICS

- Adjustable fan speed
- Power consumption: 140W max.
- Power supply: 100/240V, AC - 50/60Hz
- Net weight: 5.5 kg

#### PACKAGE CONTENTS

- The moving head
- Quicklock/Omega fixation holder
- The user guide
- 1 safety cable
- 1 DMX cable
- 1 x 2 poles + earth power cord / powerCON







# **LIGHT PERFORMERS**

# PIXXEN

L'invasion de la technologie LED\*

\*The LED technology invasion

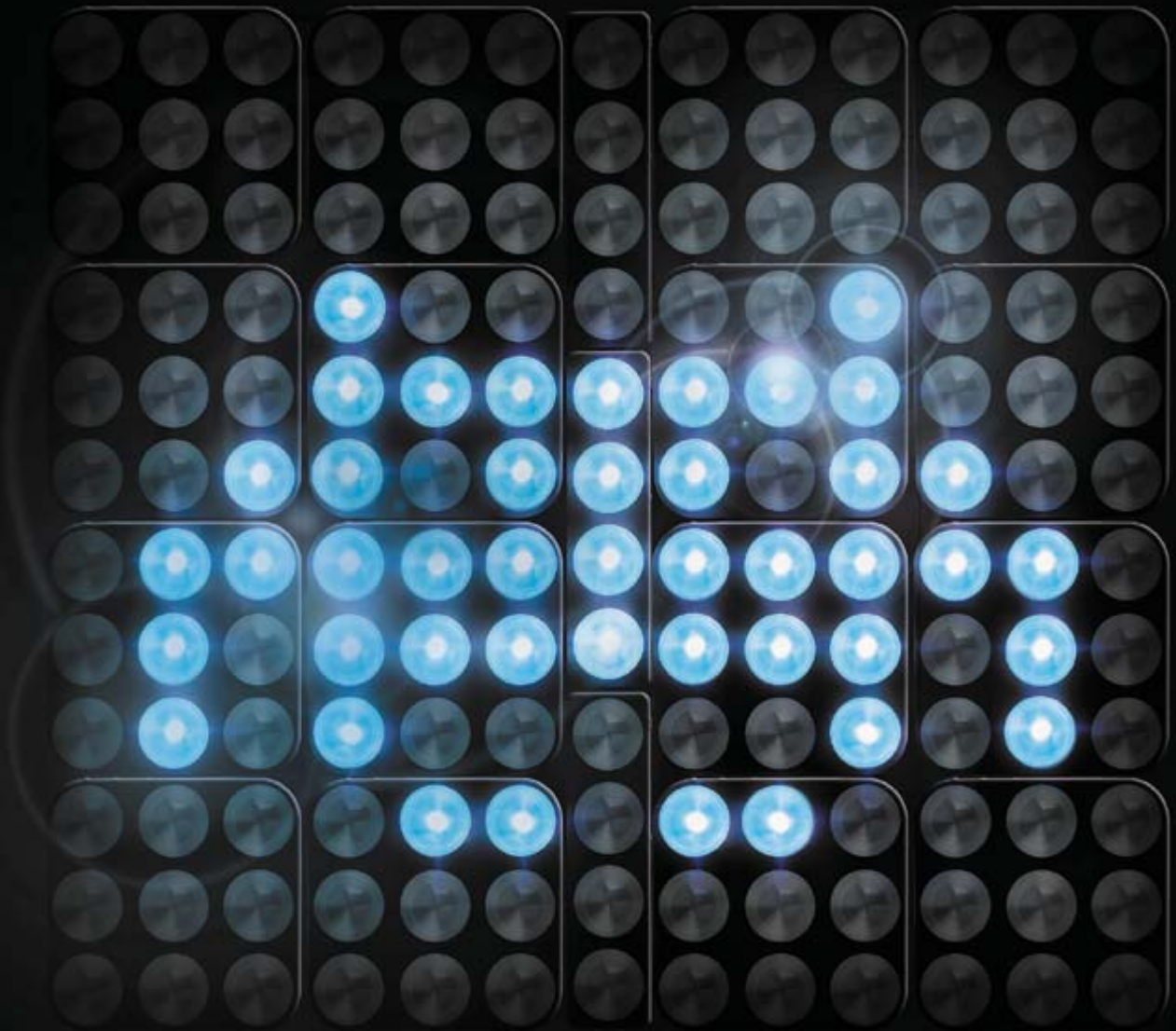

by **Contest**<sup>®</sup>





BRIGHT VIVID COLOURS, MULTI-PROJECTOR SEQUENCING, MANUAL, DMX OR AUTO PIXEL EFFECTS



### Total control via sweetlight pixel

Create efficient and impressive animations with our Sweetlight control Pixel module.

No new complex protocols. Enjoy the simplicity of your PIXXEN projectors endless control possibilities via three simple tools: gradations, step/fade sequencing or text writing.

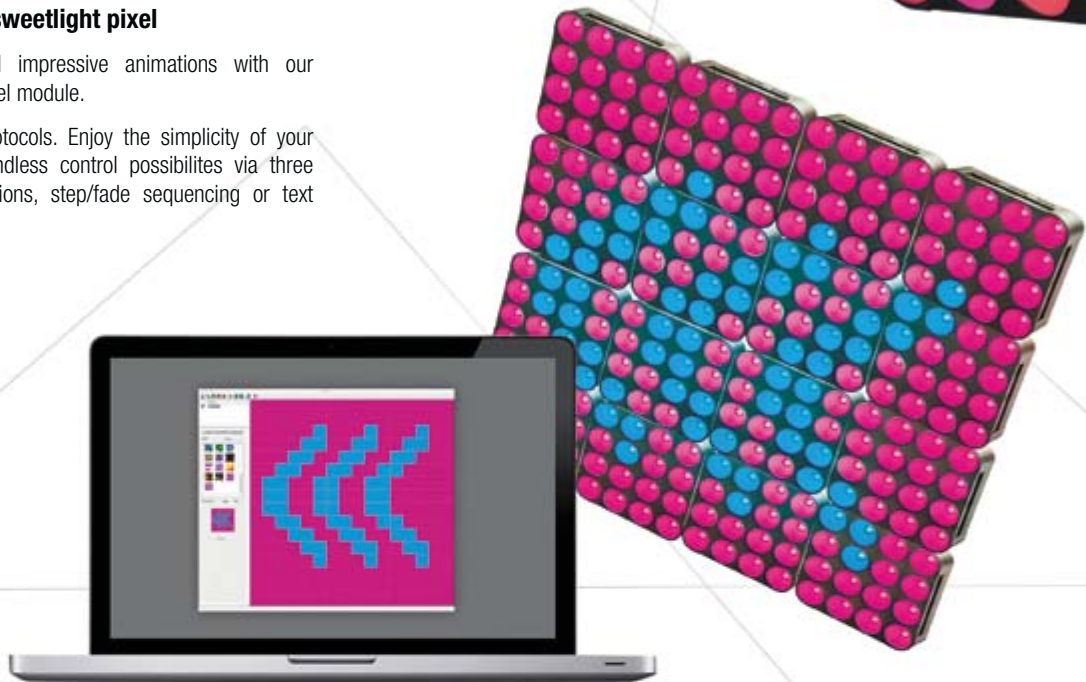

### Impressing is easy

The PIXXEN range was designed to be easy to handle.

- Multi-mode DMX
- Master/Slave mode with sequencing programs
- Upgrade your software via USB and an external software



**WELCOME TO THE FUTUR**

Vast colorimetry, outstanding brightness and tremendous power.  
The Chip On Board technology extends the LED abilities.

- MORE POWER over a small area
- OPTIMAL COLOR RENDERING thanks to the multiplication of the sources.
- BETTER CONSISTENCY thermal dissipation directly on the aluminium plate



# PIX44

16 LEDs 30 W TRI COB Flood Projector

**The perfect multipurpose projector**

ref 10016



- + Huge 480 W power output
- + Very wide aperture angle
- + Vast colour palette
- + Auto and DMX pixel mapping



- + 240 W for an outstanding power
- + Very wide aperture angle
- + Vast colour palette
- + Auto and DMX pixel mapping



# PIX18

LED Bar with 8 30W TRI COB LEDs

**Online gradiation and animation effects**

ref 10018

# PIX14

LED Bar with 4 30-W TRI COB LEDs

**An ultra-compact and incredible brightness**

ref 10017

**A 60° APERTURE**

The COB technology coupled with an aluminium parabolic reflector and a 60° beam offers an unrivaled magnificent render and homogeneity.



- + 120 W of outstanding power
- + Very wide aperture angle
- + Vast colour palette
- + 20 auto-sequenced projectors





# PIX9W44

6x9W TRI LEDs Floodlight projector

**Multicoloured pixel effects**

ref 10135

A very powerful projector allowing flash effects and step-by-step incredible animations.

- + Bright, vivid colours
- + Create multi-projector sequences
- + Pixel effects with the Auto, DMX or Manual modes



- + Bright, vivid colours
- + Create multi-projector sequences
- + Pixel effects with the Auto, DMX or Manual modes

# PIX9W33

9x9W TRI LEDs Floodlight projector

**Combining many effects**

ref 10133

The PIX9W33 has more than one strings to its bow. It is capable of Pixel effects, colour gradations, and quick or progressive colour-changing. It benefits of all the PIXXEN series features in a very compact format. It really is top of the line when it comes to displaying animations, or creating visual atmospheres.

# PIX9W14

4x9W TRI LED light bar

**The most compact PIXXEN projector**

ref 10134

The PIX9W14 fits in nomad and permanent installations thanks to its double suspension bracket. It is compact, powerful, very efficient and is designed for online effects. You can create sequences with up to 20 projectors to flood the dancefloor with vivid, intense colours.

- + Bright, vivid colours
- + Create multi-projector sequences
- + Pixel effects with the Auto, DMX or Manual modes
- + Double suspension brackets for an optimal ground handling



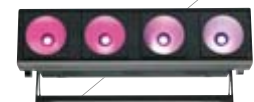

|                                    | <b>PIX44</b>   | <b>PIX18</b>                   | <b>PIX14</b>                   |
|------------------------------------|--|--------------------------------|--------------------------------|
| <b>Ref</b>                         | 10016  | 10018                          | 10017                          |
| <b>Number of LEDs</b>              | 16 COB TRI LEDs  | 8 COB TRI LEDs                 | 4 COB TRI LEDs                 |
| <b>LEDs model</b>                  | 30 W COB TRI   |                                |                                |
| <b>Beam aperture</b>               | 60°  |                                |                                |
| <b>OPERATING MODE</b>              |  |                                |                                |
| <b>DMX channels</b>                | 2/3/4/5/6/48 or 51   | 2/3/4/5/6/24 or 27             | 2/3/4/5/6/12 or 15             |
| <b>Programmed colours</b>          | 10 colours in direct access                                  |                                |                                |
| <b>Built-in colour programs</b>    | 5 fade/step colour macros                                    |                                |                                |
| <b>Built-in animation programs</b> | 8 pattern sequences with a chaser                            |                                |                                |
| <b>Speed adjustment</b>            | 1-99   |                                |                                |
| <b>Audio mode</b>                  | sensitivity 1-99   |                                |                                |
| <b>Multi-slaves mode</b>           | Auto-sequencing up to 5 PIX44                                | Auto-sequencing up to 10 PIX18 | Auto-sequencing up to 20 PIX14 |
| <b>SPECIFICATIONS</b>              |  |                                |                                |
| <b>DMX connectors</b>              | 3 pins IN/OUT XLR connectors<br>5 pins IN/OUT XLR connectors |                                |                                |
| <b>Power supply connectors</b>     | PowerCON® INPUT/OUTPUT                                       |                                |                                |
| <b>Cooling system</b>              | 4 thermo-regulated fans                                      | 1 thermo-regulated fan         | 1 thermo-regulated fan         |
| <b>Power supply</b>                | 100/240V - 50/60Hz, AC                                       | 100/240V - 50/60Hz, AC         | 100/240V - 50/60Hz, AC         |
| <b>Power consumption</b>           | 500 W  | 240 W                          | 120 W                          |
| <b>Measurements</b>                | 345 x 365 x 180 mm   | 880 x 170 x 150 mm             | 440 x 170 x 150 mm             |
| <b>Net weight</b>                  | 8.25 kg  | 8 kg                           | 5 kg                           |

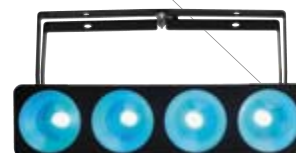

|                                    | <b>PIX9W44</b>                                | <b>PIX9W33</b>                   | <b>PIX9W14</b>                  |
|------------------------------------|---|----------------------------------|---------------------------------|
| <b>Ref</b>                         | 10135   | 10133                            | 10134                           |
| <b>Number of LEDs</b>              | 16 RGB LEDs                                   | 9 RGB LEDs                       | 4 RGB LEDs                      |
| <b>LEDs model</b>                  | 9 W RGB LEDs - Expected lifespan 30.000 hours |                                  |                                 |
| <b>Beam aperture</b>               | 25°   |                                  |                                 |
| <b>OPERATING MODE</b>              |   |                                  |                                 |
| <b>DMX channels</b>                | 2/3/4/5/6/48 or 51                            | 2/3/4/5/6/27 or 30               | 2/3/4/5/6/12 or 15              |
| <b>Programmed colours</b>          | 10 colours in direct access                   |                                  |                                 |
| <b>Built-in colour programs</b>    | 5 fade/step colour macros                     |                                  |                                 |
| <b>Built-in animation programs</b> | 8 pattern sequences with a chaser             |                                  |                                 |
| <b>Speed adjustment</b>            | 1-99  |                                  |                                 |
| <b>Audio mode</b>                  | Sensitivity 1-99                              |                                  |                                 |
| <b>Multi-slaves mode</b>           | Auto-sequencing up to 5 PIX9W44               | Auto-sequencing up to 10 PIX9W33 | Auto-sequencing up to 9 PIX9W14 |
| <b>SPECIFICATIONS</b>              |   |                                  |                                 |
| <b>DMX connectors</b>              | 3 pins IN/OUT XLR connectors                  |                                  |                                 |
| <b>Power supply connectors</b>     | IEC input/output                              |                                  |                                 |
| <b>Cooling system</b>              | Thermo-regulated fan                          | Thermo-regulated fan             | Convection                      |
| <b>Power supply</b>                | AC 100/240V - 50/60Hz                         |                                  |                                 |
| <b>Power consumption</b>           | 200 W   | 110 W                            | 48 W                            |
| <b>Measurements</b>                | 345 x 345 x 180 mm                            | 260 x 260 x 180 mm               | 340 x 140 x 140 mm              |
| <b>Net weight</b>                  | 7.7 kg  | 4.9 kg                           | 2.9 kg                          |

# irLED64-18x12SIX

Une puissance phénoménale et 6 couleurs incroyables\*

\*6 flamboyant colours and an incredible power

version  
SILVER

version  
BLACK

by **Contest**<sup>®</sup>





EXCLUSIVE COLOUR PALETTE  
 NEW 12 WATTS SIX LEDS  
 NEW SELF-LOCKING MOUNTING BRACKET  
 NEW CONTROL OPTIONS



### Sublimated by uv light

UV light is used to enhance white shades, turning them into an intense phosphorescent white. When UV light is added to stronger colours it emphasizes their contrast, deepens their shade and you obtain a whole new palette of exclusive colours.

### 256 000 billion colours

The new SIX diode offers a quasi-infinite colour palette: In addition to the Green/Red/Blue mix, the white enhances the brightness, the amber brings warmth to the bottom of the colour spectrum and the UV allows you to use all of the phosphorescent colours. The mix of shade is smooth, shadowless thanks to the individual lens system.



### Take control

The irLED64-18x12SIX offers tons of modes of operation and adapts to all kinds of events. The DMX chart can be adjusted from 2 to 9 channels. The Auto mode has numerous variable speed colour macros. You can also create your own program at the exact speed you want. Every function can be controlled via the infrared remote control.



### A user-focused design

The irLED64-18x12SIX has both DMX IN and OUT plugs allowing you to cascade up to 10 projectors. You can use all the functionalities via a wide control screen at the rear of the projector or via the supplied remote control.

### New moving head with STOP system

The irLED64-18x12SIX has a new double mounting bracket revolutionizing its ground handling. Thanks to the automatic abutment point, you can tighten the projector independently from the mounting bracket blocking. Manipulate and adjust the projector with an optimal stability.

# irLED SERIES

The Contest irLED LEDs projectors series. They feature high-performance lenses perfectly adapted to any kind of installation, with an incredible light output and projection quality. They are available with a black or aluminium finishing.

60

## irLED64-18x12SIX

Six-colour LEDs PAR projector

**A phenomenal power and incredible colours**

- + Exclusive colour palette
- + New 12 Watts SIX LEDs
- + New self-locking mounting bracket
- + New Master Dimmer mode



irLED64  
**18x12SIXss**

Finishing : Aluminium  
ref 10137

irLED64  
**18x12SIXsb**

Finishing : Satin black  
ref 10138



**REMOTE CONTROL**

The whole irLED series is supplied with remote controls. The irLED64-18x12SIX is supplied with an infrared remote control to access the colour control, built-in programs, DMX settings and a lot more.

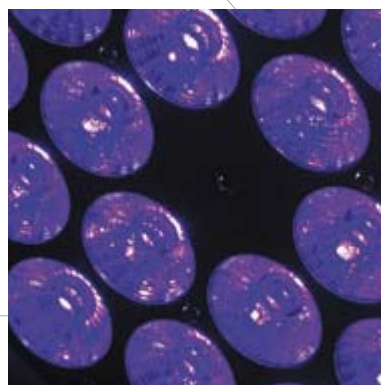
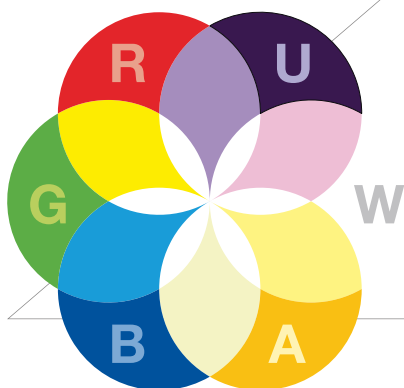

**SUBLIMATED BY UV LIGHT**

UV light is used to enhance white shades, turning them into an intense phosphorescent white.

When UV light is added to stronger colours it emphasizes their contrast, deepen their shade and you obtain a whole new palette of exclusive colours..



**NEW MOVING HEAD WITH STOP SYSTEM**

The irLED64-18x12SIX has a new double mounting bracket revolutionising ground handling. Thanks to the automatic abutment point, tightening the projector is independent from the mounting bracket blocking. You can now manipulate and adjust the projector with an optimal stability.

**FLY-irLED-64x6**

Flight case for 6 PAR64 projectors  
ref 10338



This flight case has been specifically designed to safely transport your irLED64 projectors and all their accessories.

**TECHNICAL SPECIFICATIONS**

- 18 six-colour LEDs RGB + White + Amber + Ultraviolet
- 12W LEDs - 30 000 hours
- Beamwidth : 40°
- Light output : 5020 Lux at 2 m
- High efficiency individual lenses for a perfect light diffusion
- Access to all functions via the IR remote control
- Digital display drop-down menu to change the settings
- IEC input/output sockets
- Operating mode :
  - 2-9 DMX channels
  - Fixed colours
  - Step/Fade programs with adjustable speed
- Automatic mode
- Sound sensitive automatic mode
- Slave mode
- Edit and play your own 20-step program
- Power consumption : 240 W
- Power supply : 100/240V - 50/60Hz, AC
- DMX input/output
- Black or silver aluminium housing
- Double holding bracket with STOP SYSTEM. Mechanical lock to prevent the bracket from fully opening once on the ground.
- Measurements : 340 x 270 x 220 mm
- Net weight : 5,4 kg



# irLED64-18x12SIXsb-Air

PAR64 projector with 18x6-colour LEDs and wireless DMX

**A phenomenal power and incredible colours**

Ref 10532

62



The Contest irLED LEDs projectors series. They feature high-performance lenses perfectly adapted to any kind of installation, with an incredible light output and projection quality.



- + Long-range wireless DMX reception/transmission
- + Compatible with the air-BOX
- + Compatible with airLED and IPair projectors
- + New Master Dimmer mode



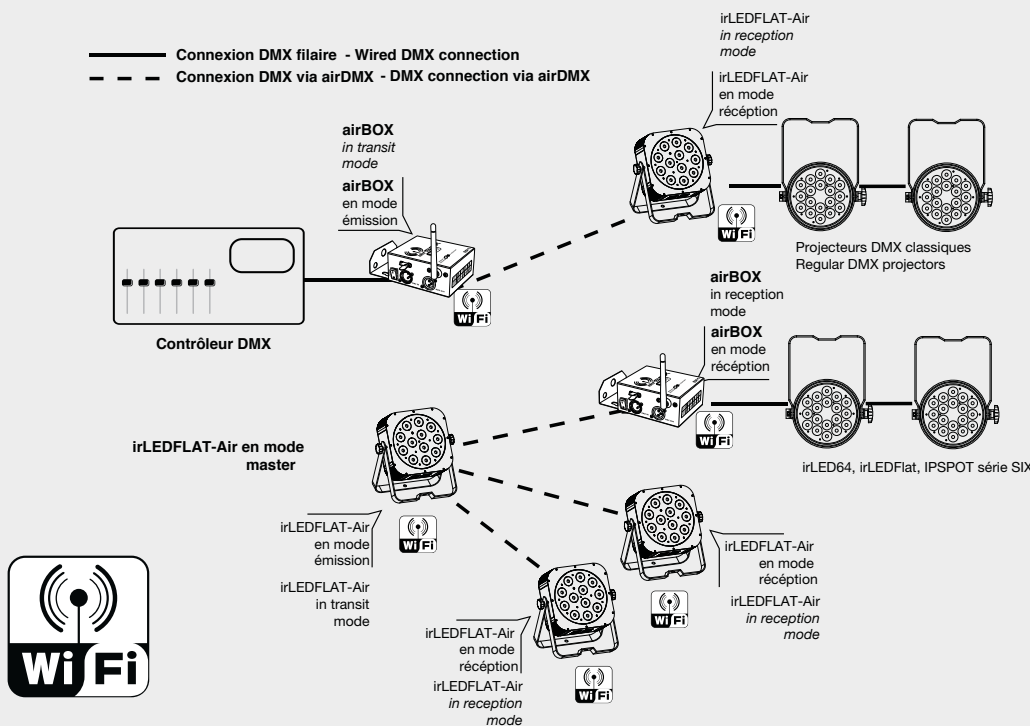

POWER,  
COLOURS AND  
THE AIRDMX  
TECHNOLOGY  
ON TOP OF  
THAT



**SUBLIMATED BY UV LIGHT**

UV light is used to enhance white shades, turning them into an intense phosphorescent white. When UV light is added to stronger colours it emphasizes their contrast, deepen their shade and you obtain a whole new palette of exclusive colours..



**REMOTE CONTROL**

The whole irLED series is supplied with remote controls. The irLED64-18x12SIX is supplied with an infrared remote control to access the colour control, built-in programs, DMX settings and a lot more.

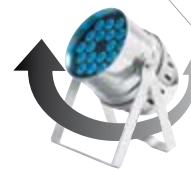

**NOUVELLE LYRE AVEC STOP SYSTEM**

The irLED64-18x12SIX has a new double mounting bracket revolutionising ground handling. Thanks to the automatic abutment point, tightening the projector is independent from the mounting bracket blocking. You can now manipulate and adjust the projector with an optimal stability.

**TECHNICAL SPECIFICATIONS**

**AIRDMX**

- Built-in AirDMX wireless receiver/transmitter
- Average range of 100m in open land
- Frequency band: 2.4 Ghz
- Compatible with the AirBox-ER1

- 18 six-colour LEDs RGB + White + Amber + Ultraviolet
- 12W LEDs - 30 000 hours
- Beamwidth : 40°
- Light output : 5020 Lux at 2 m
- High efficiency individual lenses for a perfect light diffusion
- Access to all functions via the IR remote control
- Digital display drop-down menu to change the settings
- IEC input/output sockets
- Operating mode :
  - 2-9 DMX channels
  - Fixed colours
  - Step/Fade programs with adjustable speed

- Automatic mode
- Sound sensitive automatic mode
- Slave mode
- Edit and play your own 20-step program
- Power consumption : 240 W
- Power supply : 100/240V - 50/60Hz, AC
- DMX input/output
- Black or silver aluminium housing
- Double holding bracket with STOP SYSTEM. Mechanical lock to prevent the bracket from fully opening once on the ground.
- Measurements : 340 x 270 x 220 mm
- Net weight : 5,4 kg

# irLED64-18x10FIVE

18x10W LEDs PAR Projectors with 5 colours

**5 in 1 LEDs allowing magnificent warm colours**

64

- + Primary colours + white  
+ amber
- + Exceptional rendering
- + Aperture angle: 40°
- + New Master Dimmer mode

New firmware with user program  
New mounting bracket with Stop system



## irLED64 **18x10FIVEsb**

Finishing : Satin black  
Ref 10072

## irLED64 **18x10FIVEss**

Finishing : Aluminium  
Ref 10073



## FLY-irLED-64x6

FLight case for 6 PAR64 projectors  
ref 10338

This flight case has been specifically designed to safely transport your irLED64 projectors and all their accessories.





**REMOTE CONTROL**

The whole irLED series is supplied with remote controls. The irLED64-18x12SIX is supplied with an infrared remote control to access the colour control, built-in programs, DMX settings and a lot more.



**10 W RGBWA 5 IN 1 LEDS**

The 5-colour LED allow you to mix the three primary colours and to add white to create vibrant colours, but also pastel shades. You can also add amber to add warm and unprecedented shades to your projections or beams. The 40° aperture angle is able to cover large areas.

**PILOT8**

You can now get a foothold in the spotlight without taking any risk with the PILOT-8. It is easy to access and offers many possibilities. It was designed for LEDs projectors, with 8 group-adaptable channels so you can easily mix different projectors.

Ref 10126



Page 175

**TECHNICAL SPECIFICATIONS**

|   |  |
|---|--|
| 18 x 5-colour LEDs RGB+White+Amber                              | - Automatic mode   |
| 10W LEDs - 50 000 hours   | - Sound sensitive automatic mode   |
| Beamwidth : 40°   | - Slave mode   |
| Light output : 4310 Lux at 2 m                                  | - Edit and play your own 20-step program   |
| High efficiency individual lenses for a perfect light diffusion | Power consumption : 165 W  |
| Access to all functions via the IR remote control               | Power supply : 100/240V - 50/60Hz, AC  |
| Digital display drop-down menu to change the settings           | DMX input/output socket  |
| IEC input/output sockets  | Black or silver aluminium housing  |
| Operating mode :  | Double holding bracket with STOP system  |
| - 2-8 DMX channels  | Double holding bracket with STOP SYSTEM. Mechanical lock to prevent the bracket from fully opening once on the ground. |
| - Fixed colours   | Measurements : 340 x 270 x 220 mm  |
| - Step/Fade programs with adjustable speed                      | Net weight : 4,6 kg  |

# irLED64-18x3TC

18x3W Tricolor LEDs PAR64 projector

**An ideal combination of power and beamwidth**

## 3 W TRICOLOR LEDs

The trichromatic diod mixes colors within the same lens, allowing a more accurate coloration without colored shadows.

66

Multiple modes, 18 high power trichromatic LEDs, high performance individual lenses, multifunctional remote control... The irLED64-18x3TC offers a tremendous light output without leaving out its precision. It is versatile and adapts really well to any kind of nomad or permanent installations thanks to its vast colour palette and built-in programs designed for stages, decoration and ambient lighting. The double hanging bracket can be used to suspend it or to place it on the ground safely.

- + PAR64 projector
- + Tricolor LEDs
- + 40° aperture
- + New master Dimmer mode



Infrared multi-functions remote control supplied

## irLED64 18x3TCss

Finishing : Aluminium  
ref 9875

## irLED64 18x3TCsb

Finishing : Satin black  
ref 9876

### TECHNICAL SPECIFICATIONS

|  |  |   |
|--|--|---|
| 18x3W LEDs   | IEC input/output                           | - Slave mode                            |
| 3W RGB LEDs - Expected lifespan 50.000 hours       | Operating mode:                            | Power consumption : 60 W                |
| LEDs aperture angle: 40°                           | - 2-6 DMX channels                         | Power supply : 100/240 V - 50/60 Hz, AC |
| Light output: 2670 Lux at 2 metres                 | - Fixed colours                            | Aluminium housing                       |
| Individual high performance lenses                 | - Step/Fade programs with adjustable speed | Double holding bracket                  |
| Access all functions via the IR remote control     | - Automatic mode                           | Measurements : 340 x 270 x 220 mm       |
| Display with drop-down menu to access the settings | - Sound sensitive automatic mode           | Net weight : 5 kg                       |

## FLY-irLED-64x6

Flight case for 6 PAR64 projectors  
ref 10338

This flight case has been specifically designed to safely transport your irLED64 projectors and all their accessories.





# irLED56-12x3TC

12x3W Tricolor LEDs PAR56 projector

**Tricolor and compact**



- + PAR56 projector
- + Tricolor LEDs
- + 40° aperture
- + New master Dimmer mode

## irLED56 12x3TCsb

Finishing: Satin black

ref 9872

## irLED56 12x3TCss

Finishing: Aluminium

ref 9871



Infrared multi-functions  
remote control supplied



### TECHNICAL SPECIFICATIONS

|  |  |   |
|--|--|---|
| 12x3W LEDs   | Operating mode:                            | Power supply : 100/240 V - 50/60 Hz, AC |
| 3W RGB LEDs - Expected lifespan 50.000 hours       | - 2-6 DMX channels                         | Aluminium housing                       |
| LEDs aperture angle: 40°                           | - Fixed colours                            | Double holding bracket                  |
| Light output: 1170 Lux at 2 metres                 | - Step/Fade programs with adjustable speed | Black or aluminium finishing            |
| Individual high performance lenses                 | - Automatic mode                           | Measurements : 320 x 250 x 2170 mm      |
| Access all functions via the IR remote control     | - Sound sensitive automatic mode           | Net weight : 2.8 kg                     |
| Display with drop-down menu to access the settings | - Slave mode                               |   |
| IEC input/output                                   | Power consumption : 40 W                   |   |

Light performers 5000s PAR Projectors



# GAMME Air

Faites communiquer la lumière  
pour plus de liberté\*

\*Communicate with light for more freedom



by **Contest**® 

# GAMME irLED



| Model                          | <b>irLED64<br/>18x12SIXsb-Air</b> | <b>irLED64<br/>18x12SIX</b>     | <b>irLED64<br/>18x10FIVE</b>    | <b>irLED64<br/>18x3TC</b>     | <b>irLED56<br/>12x3TC</b>     |
|--------------------------------|-----------------------------------|---------------------------------|---------------------------------|-------------------------------|-------------------------------|
| REF                            | 10532 (black)                     | 10138 (black)<br>10137 (silver) | 10072 (black)<br>10073 (silver) | 9878 (black)<br>9877 (silver) | 9872 (black)<br>9871 (silver) |
| LEDs model                     | RGBWAUV                           | RGBWAUV                         | RGBWA                           | RGB<br>(3 internal colours)   | RGB<br>(3 internal colours)   |
| Number of LEDs/power           | 18 x 12 Watts                     | 18 x 12 Watts                   | 18 x 10 Watts                   | 18 x 5 Watts                  | 12 x 3 Watts                  |
| Beamwidth                      | 40°                               | 40°                             | 40°                             | 40°                           | 40°                           |
| Light output at 2 m            | 5020 Lux                          | 5020 LUX                        | 4770 LUX                        | 2900 Lux                      | 1030 Lux                      |
| Lenses                         | Individual lenses                 | Individual lenses               | Individual lenses               | Individual lenses             | Individual lenses             |
| Input/output power socket      | Yes                               | Yes                             | Yes                             | Yes                           | Yes                           |
| Infrared remote control        | Yes                               | Yes                             | Yes                             | Yes                           | Yes                           |
| DMX channels                   | 2-9 channels                      | 2-9 channels                    | 2-8 channels                    | 2-6 channels                  | 2-6 channels                  |
| Colour macros                  | 46                                | 46                              | 32                              | 20                            | 20                            |
| Programs                       | 14                                | 14                              | 5                               | 5                             | 5                             |
| Free space for user's programs | Yes<br>1-20 steps max.            | Yes<br>1-20 steps max.          | Yes<br>1-20 steps max.          | -                             | -                             |
| Holding bracket STOP system    | Yes                               | Yes                             | Yes                             | -                             | -                             |
| Air Dmx                        | Yes                               | -                               | -                               | -                             | -                             |
| New Master Dimmer mode         | Yes                               | Yes                             | Yes                             | Yes                           | Yes                           |
| Flicker Free                   | Yes                               | Yes                             | Yes                             | -                             | -                             |
| Power consumption              | 240 W                             | 240 W                           | 165 W                           | 100 W                         | 40W                           |
| Measurements                   | 340 x 270 x 220 mm                | 340 x 270 x 220 mm              | 340 x 270 x 220 mm              | 340 x 270 x 220 mm            | 320 x 250 x 170 mm            |
| Net weight                     | 5,4 kg                            | 5,4 kg                          | 4,6 kg                          | 5 kg                          | 2,8 kg                        |



# GAMME irLEDFLAT

La rencontre entre UV et couleur\*

\*Where UV and colour meet



by **Contest**<sup>®</sup>





# irLED FLAT SERIES

LEDs compact projectors  
UV-boosted colours

- Exclusive color palette  
RGB + White + Amber + Ultraviolet LEDs
- 12 Watts SIX LEDs
- Self-locking mounting bracket
- Wireless DMX



## Sublimated by UV light

UV light is used to enhance white shades, turning them into an intense phosphorescent white. When UV light is added to stronger colours it emphasizes their contrast, deepens their shade and you obtain a whole new palette of exclusive colours.

## Take control

The irLEDFLAT series offers tons of mode of operation and adapts to all kinds of events. The DMX chart can be adjusted from 2 to 9 channels. The Auto mode has numerous variable speed colour macros. You can also create your own program at the exact speed you want. The whole functions can be controlled via the infrared remote control.



# irLEDFLAT-12x12SIX

72

Six-colour LEDs compact projector

**Maximum power has never been so small**

ref 10143

- + Exclusive colour palette
- + 12 Watts SIX LEDs
- + Beamwidth 40°
- + Wireless function (Air version)
- + New Master Dimmer mode



## irLEDFLAT- 12x12SIXb

Finishing : Aluminium

Ref 10143

## irLEDFLAT- 12x12SIXb-Air

With wireless DMX

Ref 10526



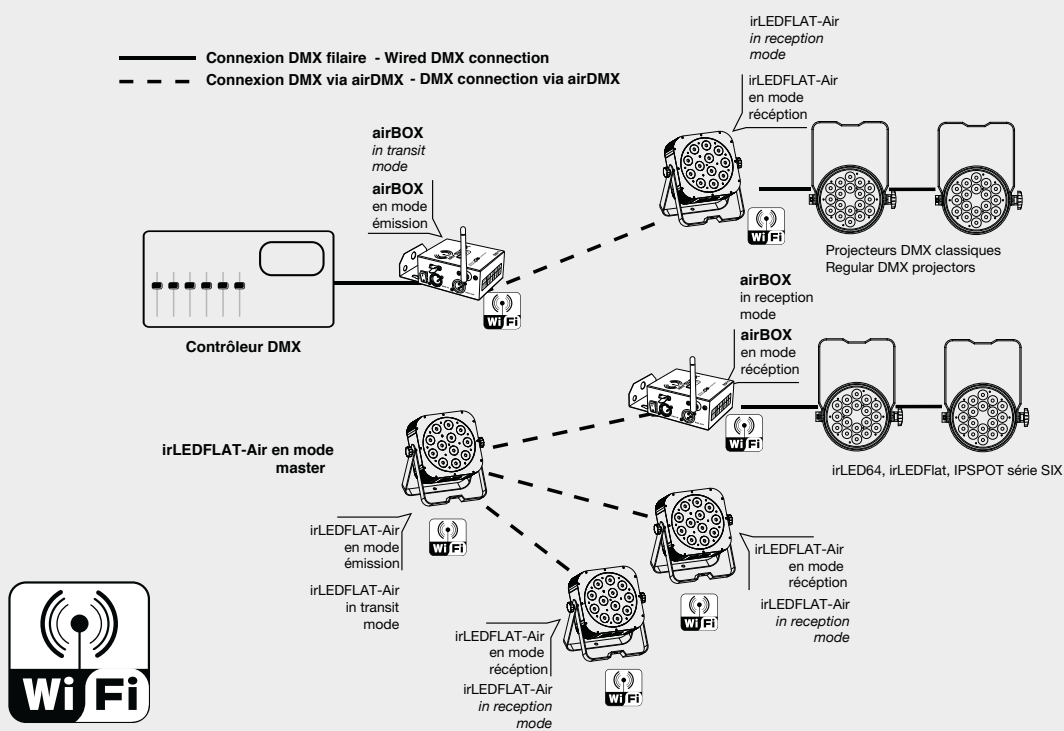

PERFECT TO START YOUR DMX CIRCUIT AND AVOID CABLES FROM YOUR CONTROLLER



**SUBLIMATED BY UV LIGHT**



UV light is used to enhance white shades, turning them into an intense phosphorescent white.

When UV light is added to stronger colours it emphasizes their contrast, deepen their shade and you obtain a whole new palette of exclusive colours.



**NEW BRACKET WITH STOP SYSTEM**

The six-colour Flat series has a new double mounting bracket revolutionizing its ground handling. Thanks to the automatic abutment point, tightening the projector is independent from the mounting bracket blocking. You can now manipulate and adjust the projector with an optimal stability

**REMOTE CONTROL**



The whole irLED series is supplied with remote controls. The six-colour Flat series is supplied with an infrared remote control to access the colour control, built-in programs, DMX settings and a lot more.



**FLY8-IRLEDFLAT**

Flight-case for 8x FLAT12SIX  
ref 10739

**TECHNICAL SPECIFICATIONS**

**AIRDMX**

- Built-in AirDMX wireless receiver/transmitter
- Average range of 100m in open land
- Frequency band: 2.4 Ghz
- Compatible with the AirBox-ER1

- 5xSix-colour LEDs RGB + White + Amber + Ultraviolet
- 12W LEDs - 30 000 hours
- Beamwidth : 40°
- Light output : 580 Lux at 3 m
- High performance individual lenses for a perfect light diffusion
- Access to all functions via the IR remote control
- Digital display drop-down menu to change the settings
- IEC input/output sockets
- Operating modes:
  - 2-9 DMX channels
  - Fixed colours

- Step/Fade programs with adjustable speed
- Automatic mode
- Sound sensitive automatic mode
- Slave mode
- Edit and play your own 20-step program
- Power consumption : 80 W
- Power supply : AC 100/240V - 50/60Hz
- DMX input/output
- Double holding bracket with STOP SYSTEM. Mechanical lock to prevent the bracket from fully opening once on the ground.
- Measurements : 240 x 265 x 110 mm
- Net weight : 2,8 kg

# irLEDFLAT-5x12SIXb

74

Six-colour LEDs compact projector

**Maximum power has never been so small**

- + Exclusive colour palette
- + 12 Watts SIX LEDs
- + Beamwidth 40°
- + DMX Wireless function
- + New Master Dimmer mode



## irLEDFLAT- **5x12SIXSb**

Finishing : Aluminium  
Ref 10142



## irLEDFLAT- **5x12SIXb-Air**

With wireless DMX  
Ref 10525





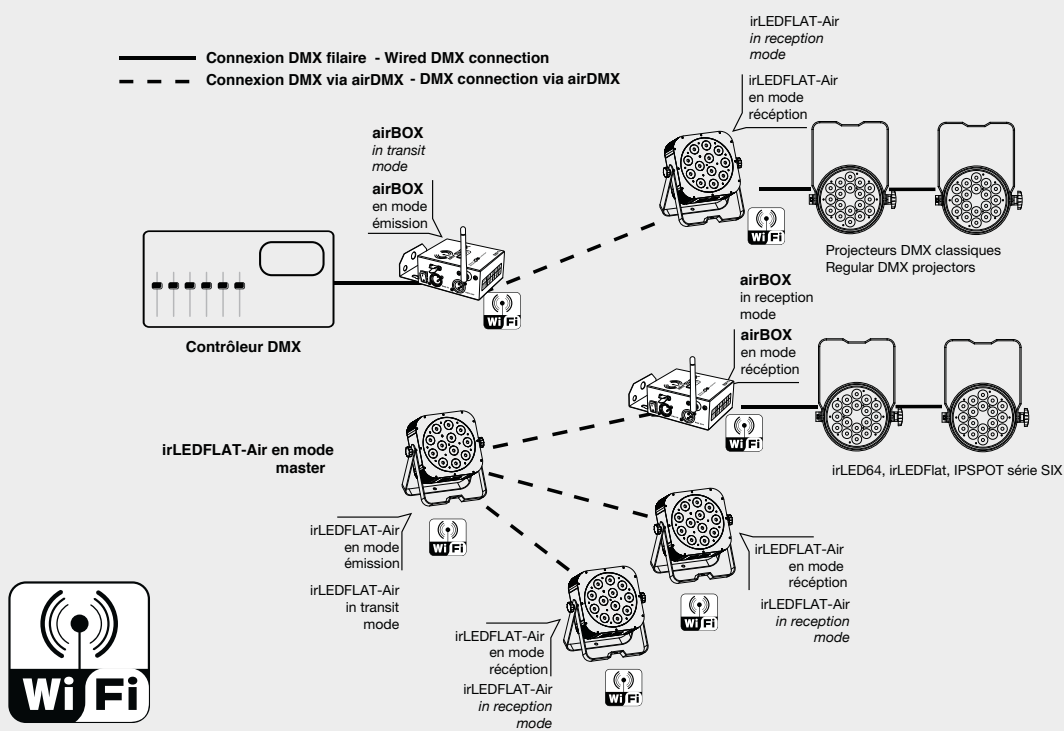

PERFECT TO START YOUR DMX CIRCUIT AND AVOID CABLES FROM YOUR CONTROLLER



**SUBLIMATED BY UV LIGHT**



UV light is used to enhance white shades, turning them into an intense phosphorescent white. When UV light is added to stronger colours it emphasizes their contrast, deepen their shade and you obtain a whole new palette of exclusive colours.

**REMOTE CONTROL**



The whole irLED series is supplied with remote controls. The six-colour Flat series is supplied with an infrared remote control to access the colour control, built-in programs, DMX settings and a lot more.



**NEW BRACKET WITH STOP SYSTEM**

The six-colour Flat series has a new double mounting bracket revolutionizing its ground handling. Thanks to the automatic abutment point, tightening the projector is independent from the mounting bracket blocking. You can now manipulate and adjust the projector with an optimal stability



**FLY8-IRLEDFLAT**

Flight-case for 8x FLAT12SIX  
ref 10739

**TECHNICAL SPECIFICATIONS**

**AIRDMX**

- Built-in AirDMX wireless receiver/transmitter
- Average range of 100m in open land
- Frequency band: 2.4 Ghz
- Compatible with the AirBox-ER1

- 5xSix-colour LEDs RGB + White + Amber + Ultraviolet
- 12W LEDs - 30 000 hours
- Beamwidth : 40°
- Light output : 580 Lux at 3 m
- High performance individual lenses for a perfect light diffusion
- Access to all functions via the IR remote control
- Digital display drop-down menu to change the settings
- IEC input/output sockets
- Operating modes:
  - 2-9 DMX channels
  - Fixed colours

- Step/Fade programs with adjustable speed
- Automatic mode
- Sound sensitive automatic mode
- Slave mode
- Edit and play your own 20-step program
- Power consumption : 80 W
- Power supply : AC 100/240V - 50/60Hz
- DMX input/output
- Double holding bracket with STOP SYSTEM. Mechanical lock to prevent the bracket from fully opening once on the ground.
- Measurements : 240 x 265 x 110 mm
- Net weight : 2,8 kg

# irLEDFLAT-3x12SIXb

Six-colour LEDs compact projector

**An ultra-compact, infinite colour palette**

ref 10141

76



- + Exclusive colour palette
- + New 12 Watts SIX LEDs
- + New self-locking mounting bracket
- + New Master Dimmer mode



## FLY8-IRLEDFLAT

Flight-case for 8x FLAT12SIX

ref 10739

### TECHNICAL SPECIFICATIONS

3xSix-colour LEDs RGB + White + Amber + Ultraviolet

3x12W LEDs- 30 000 hours

Beamwidth : 40°

Light output : 300 Lux at 3 m

High performance individual lenses for a perfect light diffusion

Access to all functions via the IR remote control

Digital display drop-down menu to change the settings

IEC input/output sockets

Operating mode:

- 2-9 DMX channels
- Fixed colours

- Step/Fade programs with adjustable speed

- Automatic mode

- Sound-sensitive automatic mode

- Slave mode

- Edit and play your own 20-step program

Power consumption : 45 W

Power supply: 100/240V - 50/60Hz, AC

DMX input/output

Double holding bracket with STOP SYSTEM, Mechanical lock to prevent the bracket from fully opening once on the ground.

Measurements :212 x 218 x 110 mm

Net weight : 2,1 kg

# irLEDFLAT SERIES



| MODEL                             | irLEDFLAT-12x12SIXb | irLEDFLAT-12x12SIXb-Air | irLEDFLAT-5x12SIXb  | irLEDFLAT-5x12SIXb-Air | irLEDFLAT-3x12SIXb  |
|-----------------------------------|---------------------|-------------------------|---------------------|------------------------|---------------------|
| Ref                               | 10143               | 10526                   | 10142               | 10525                  | 10141               |
| LEDs model                        | RGBWA+UV            | RGBWA+UV                | RGBWA+UV            | RGBWA+UV               | RGBWA+UV            |
| Number of LEDs/<br>power          | 12 X 12 W           | 12 X 12 W               | 5 X 12 W            | 5 X 12 W               | 3 X 12 W            |
| Beamwidth                         | 40°                 | 40°                     | 40°                 | 40°                    | 40°                 |
| Light output at<br>3 m            | 1400 LUX            | 1400 LUX                | 680 LUX             | 680 LUX                | 300 LUX             |
| Lenses                            | Individual lenses   | Individual lenses       | Individual lenses   | Individual lenses      | Individual lenses   |
| Input/output<br>power socket      | Yes                 | Yes                     | Yes                 | Yes                    | Yes                 |
| Infrared remote<br>control        | Yes                 | Yes                     | Yes                 | Yes                    | Yes                 |
| DMX channels                      | 2-9 channels        | 2-9 channels            | 2-9 channels        | 2-9 channels           | 2-9 channels        |
| Colour macros                     | 46                  | 46                      | 46                  | 46                     | 46                  |
| Programs                          | 14                  | 14                      | 14                  | 14                     | 14                  |
| Free space for<br>user's programs | YES 1-20 steps max. | YES 1-20 steps max.     | YES 1-20 steps max. | YES 1-20 steps max.    | YES 1-20 steps max. |
| Holding bracket<br>STOP system    | Yes                 | Yes                     | Yes                 | Yes                    | Yes                 |
| Flicker Free                      | Yes                 | Yes                     | Yes                 | Yes                    | Yes                 |
| Air DMX                           | No                  | Yes                     | No                  | Yes                    | No                  |
| New Master<br>DimmerMode          | Yes                 | Yes                     | Yes                 | Yes                    | Yes                 |
| Power consump-<br>tion            | 160 W               | 160 W                   | 80 W                | 80 W                   | 45 W                |
| Measurements                      | 275 x 310 x 110 mm  | 275 x 310 x 110 mm      | 240 x 265 x 110 mm  | 240 x 265 x 110 mm     | 212 x 218 x 110 mm  |
| Net weight                        | 3,4 kg              | 3,4 kg                  | 2,8 kg              | 2,8 kg                 | 2,1 kg              |

## DAISY-CHAINING ACCESSORIES

### IECMF1

1m male/female IEC power cord  
ref 9889

### IECMF3

3m male/female IEC power cord  
ref 9890

### IECMF5

5m male/female IEC power cord  
ref 9891

### IECMF7

7m male/female IEC power cord  
ref 9892

# irLEDFLAT-5x50C

5x5W Quadricolor LEDs compact projector  
**Pastel, vivid colours**

- + Compact format
- + Quadricolor LEDs
- + 40° aperture
- + New Master Dimmer mode



## irLEDFLAT-5X50Cb

ref 9917

## irLEDFLAT-5X50Cb-Air

Avec DMX sans fil  
ref 10524



- + Compact format
- + Quadricolor LEDs
- + Clear crystal 25° lenses
- + Clear crystal 10° lenses (10° version)
- + More than 1800 Lux at 3m
- + New Master Dimmer mode



## irLEDFLAT-5X50Cb25°

ref 9973

## irLEDFLAT-5X50Cb10°-Air

Avec DMX sans fil  
ref 10527





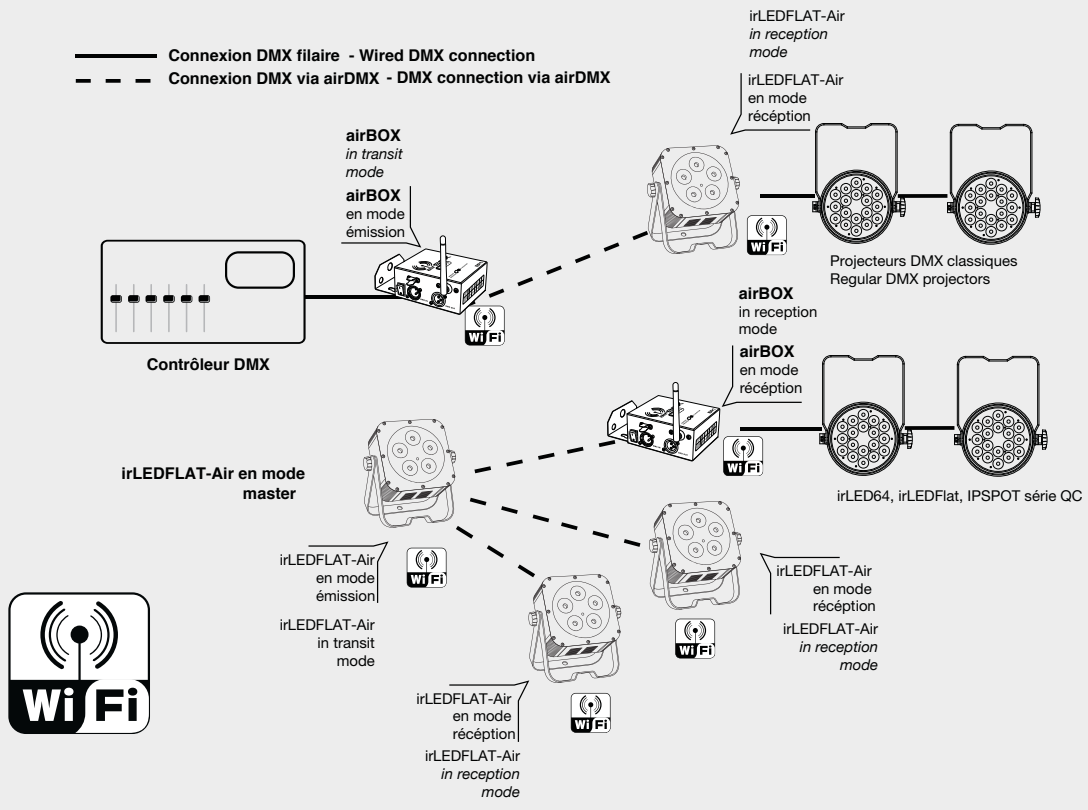

PERFECT TO START YOUR DMX CIRCUIT AND AVOID CABLES FROM YOUR CONTROLLER



**RGBW**  
Adding white unlocks a whole range of pastel colours, inaccessible until now, and colours more natural and shinier than ever.

**40° | 25° | 10°**  
Its 5 high-power 4-colour LEDs with high-performance individual lenses allow this projector to deliver a remarkable brightness and colour spreading, while remaining discreet. The 4-colour irLEDFLAT is perfect for indoor lighting and emphasizing on volumes, and offers a vast colour palette with wide aperture angle.



**REMOTE CONTROL**  
The whole irLED series is supplied with remote controls to access the colour control, built-in programs, DMX settings and a lot more.



**FLY8-IRLEDFLAT**  
Flight-case for 8x FLAT12SIX  
ref 10739

**TECHNICAL SPECIFICATIONS**

**AIRDMX**  
Built-in AirDMX wireless receiver/transmitter  
Average range of 100m in open land  
Frequency band: 2.4 Ghz  
Compatible with the AirBox-ER1

5x5W quadrichromic LEDs - Expected lifespan 50.000 hours  
**irLEDFLAT-5X5QCb & irLEDFLAT-5X5QCb-Air**  
Beam aperture angle: 40°  
Light output: 640 Lux at 3 metres  
**irLEDFLAT-5X5QCb25°**  
Beam aperture angle: 25°  
Light output: 1890 Lux at 3 metres  
Modes:  
2-7 DMX channels  
Fixed colours  
Fade/Step programs with adjustable speed  
Automatic mode

Music-sensitive auto mode  
Slave mode  
Power consumption: 30 W  
Power supply : 100/240V - 50/60 Hz, AC  
Power input/output  
DMX input/output  
Infrared remote control  
Infrared sensor (at the front) + remote sensor with a 1m power cord  
Black aluminium housing  
Double suspension bracket  
Dimensions: 240 x 110 x 265 mm  
Net weight: 2.8 kg

# irLEDFLAT-1x30TCb

Le projecteur grand-angle\*

\*It sees things big



by **Contest**





# irLEDFLAT-1x30TCb

30W COB LED compact projector

**A wide angle projector**

Ref 10130

State-of-the-art technology met power and the irLEDFLAT-1X30TCb projector, was born. The detachable condenser lens offers two aperture angles: 25° and 80°, its beam is both incredibly powerful and colourful.

- + 2 aperture angles :  
25° and 80°
- + 30W trichromic diod -  
COB technology



## TECHNICAL SPECIFICATIONS

|   |  |
|---|--|
| 1 RGB LED   | Fade/Step programs with adjustable speed |
| 30W COB LED - Expected lifespan 30.000 hours  | Automatic mode                           |
| Beamwidth: 25°-80°  | Music-sensitive auto mode                |
| Light output: 410 Lux at 3 meters with a 25° angle  | Slave mode                               |
| A condenser lens allows you to reduce the beam aperture angle, adding more range to the beam with the same colour quality | Play and edit your own 20-step program   |
| Display with drop-down menu to access the settings  | Power consumption: 45W                   |
| IEC power input/output  | Power supply: 100/240V - 50/60Hz, AC     |
| Modes:  | DMX input/output                         |
| 2-6 DMX channels  | Double suspension bracket                |
| Fixed colours   | Dimensions: 208 x 221 x 120 mm           |
|   | Net weight: 2.1 kg                       |

# IPair 5x12Six

Projecteur IP65, Air DMX, sur batterie\*

\*Battery-operated, IP 65 Air DMX projector





# IPAIR-5x12SIX

IP65, AirDMX, battery-operated projector

**5 x 12W 6-in-1 LEDs**

ref 10411



IPair-5x12SIX is a new weatherproof projector equipped with 5 x 12W RGBWA + UV LEDs, suitable for mains or battery operations.

It also features a built-in WiFi receiver/transmitter compatible with any AirDMX product, a Lithium battery and infrared remote control. That means it is always ready to illuminate any place you want, both indoors and outdoors.

- + Protected against water projections
- + Strong aluminium housing
- + 12W RGBWA UV LEDs (6-in-1)
- + Wifi DMX compatible AirBox, Air
- + Weatherproof IN/OUT DMX and IN/OUT power sockets
- + New Master Dimmer mode
- + Compatible with 220 and 290mm squares structures
- + Ergonomic housing for ground handling 5-position adj

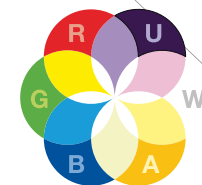

## FLY-IPAIRx6

Flight case designed for 6 IPAIR-5x12SIX

ref 10464

This flight case has been specifically designed to safely transport 6 of your IPAIR-5x12SIX projectors and all their accessories.



The housing can be directly installed onto the ground to create amber lighting effects. The housing can be adjusted via its adjustable bracket with 5 positions located beneath the projector.



### TECHNICAL SPECIFICATIONS

#### OPTICAL SYSTEM

- 5 x 12W 6-in-1 LEDs - 30 000 hours
- Light output: 844 Lux at 3m
- Clear Crystal lenses to perfectly spread beams
- Beamwidth: 25°

#### AIRDMX

- Built-in airDMX wireless receiver/transmitter
- Average range of 100m in open area
- Frequency range: 2.4 GHz
- Compatible with the AirBox-ER1

#### FUNCTIONS

- Drop-down display allowing you to:
- Choose the DMX address
- Choose the number of channels: from 3 - 10
- Choose the built-in programs
- Choose the preset colours
- Master/Slave mode
- 20-step customisable user program
- Infrared remote control

#### CONNECTORS

- DMX IN and OUT via 3-pin IP sockets,
- POWER IN/OUT via 3-pin IP sockets

#### ADDITIONAL CHARACTERISTICS

- Power supply: 100-240V/50-60Hz
- Power consumption: 65 W
- 12-cell Lithium battery 22,2V 4,4Ah 500 charge cycles max.
- Battery life: 6 hours with colour changes  
4 hours when using white (RGBW)
- Charge cycle: 5 hours
- Tightness level: IP65
- Finish: Black
- Dimensions: 240 x 165 x 280 mm
- Weight: 3.5 kg

#### PACKAGE CONTENTS

- The moving head
- The user guide
- An adjustable double mounting bracket
- An infrared remote control
- A 2 poles + earth IP/IEC cord

### ACCESSORIES

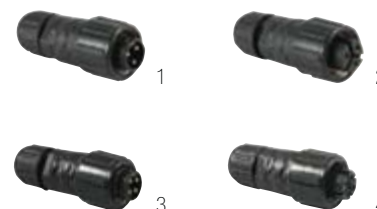

|   |       |           |  |
|---|-------|-----------|--|
| 1 | 10465 | FCIP-DMXm | Male waterproof DMX plug for IPAIR- IP68     |
| 2 | 10466 | FCIP-DMXf | Female waterproof DMX plug for IPAIR- IP68   |
| 3 | 10467 | FCIP-POWm | Male waterproof POWER plug for IPAIR- IP68   |
| 4 | 10468 | FCIP-POWf | Female waterproof POWER plug for IPAIR- IP68 |

# airLED9x3TCb

A unique portable spot light.

**A total autonomy**

ref 9957

84



## THIS IS A ONE-OF-A-KIND PORTABLE SPOTLIGHT.

It either works with a battery or plugged into an AC outlet, with a wired DMX signal, but also wirelessly (via Wi-Fi). It features all the characteristics of the irLED series: an exceptional coloration thanks to the individual lenses, the 3 Watts trichromatic LEDs produce an incredible brightness, and it is supplied with an infrared remote control.

- + Operates either with a battery or plugged
- + DMX reception and transmission via Wi-Fi (airDMX)

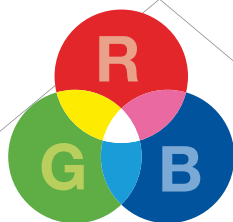

### THE AIRDMX NETWORK

The airLED-9x3tcb projector is an airDMX device. In addition of all the classic characteristics of a projector it can be perfectly integrated in any airDMX network either as a receiver or as a transmitter and broadcast an incoming wired DMX signal into a Wi-Fi signal.



**A SEVERAL HOURS AUTONOMY**

The lithium-ion battery provides many benefits: it has an impressive autonomy, it does not require specific adaptators to be charged (just a regular AC socket), and can be used and stored in any position (lithium-ion batteries are acid-free).



**TRICOLOR LEDS**

The trichromatic diode mixes colors within the same lens allowing a more accurate coloration without colored shadows.



**TAKE CONTROL**

The airLED-9x3tcb has its own infrared remote control that you can use to access the settings and all the internal colors as well as a user program allowing you to create your own sequencing. The aerial, wired master-slave mode can synchronize several projectors simultaneously.

**TECHNICAL SPECIFICATIONS**

- 9x3W LEDs
- 3W tricolor LEDs - 50 000 hours
- Beamwidth : 40°
- Light output : 1160 Lux at 3 m
- High performance individual lenses
- airDMX Wi-Fi transmitter or receiver via 7 frequencies
  - Average range of 100m in open space\*
  - Frequency range 2.400-2.483GHz ISM
  - Compatible with the AirBox-ER1
- Integrated 21-cell lithium-ion battery.
  - Full charge : approximately 5 hours
  - Autonomy : approximately 56 hours at full power / approximately 9 hours with colour changes\*
  - Can be used while recharging
- Digital drop-down display
- Operating mode :
  - 2-6 DMX channels
  - Fixed colours
  - Fade/Step programs with adjustable speed

- Customizable user program
- Automatic mode
- Sound-sensitive automatic mode
- Slave mode
- Supplied with an infrared remote control
- Power consumption: 66W
- Power supply :
  - 100/240V - 50/60Hz, AC
  - 21-cell lithium-ion battery :
  - 26V - 6.6AH - 170WH
- The battery can be charged up to 500 times
- Input/output power socket (up to 10 devices linked together for a maximum of 10 Amps)
- DMX input/output
- Metal housing
- Thermo-regulated ventilation system
- Double mounting/holding bracket
- Measurements : 200 x 200 x 148 mm
- Net weight : 4.5 kg

\* Non-contractual informations, may differ due to usage conditions.

**FLY-irLED-64x6**

Flight case for 6 PAR64 projectors  
ref 10338

This flight case has been specifically designed to safely transport your airLED projectors and all their accessories.



# THE airDMX NETWORK



You can now add Wi-Fi to your actual projectors and remotely control them with the new airDMX technology. You will save a lot of time. It is so simple, so subtle, so real.

The airDMX system is a Wi-Fi control protocol developed by Contest and fully compatible with the standard DMX

## airDMX Network

DMX wired and wireless signal transmission via airDMX

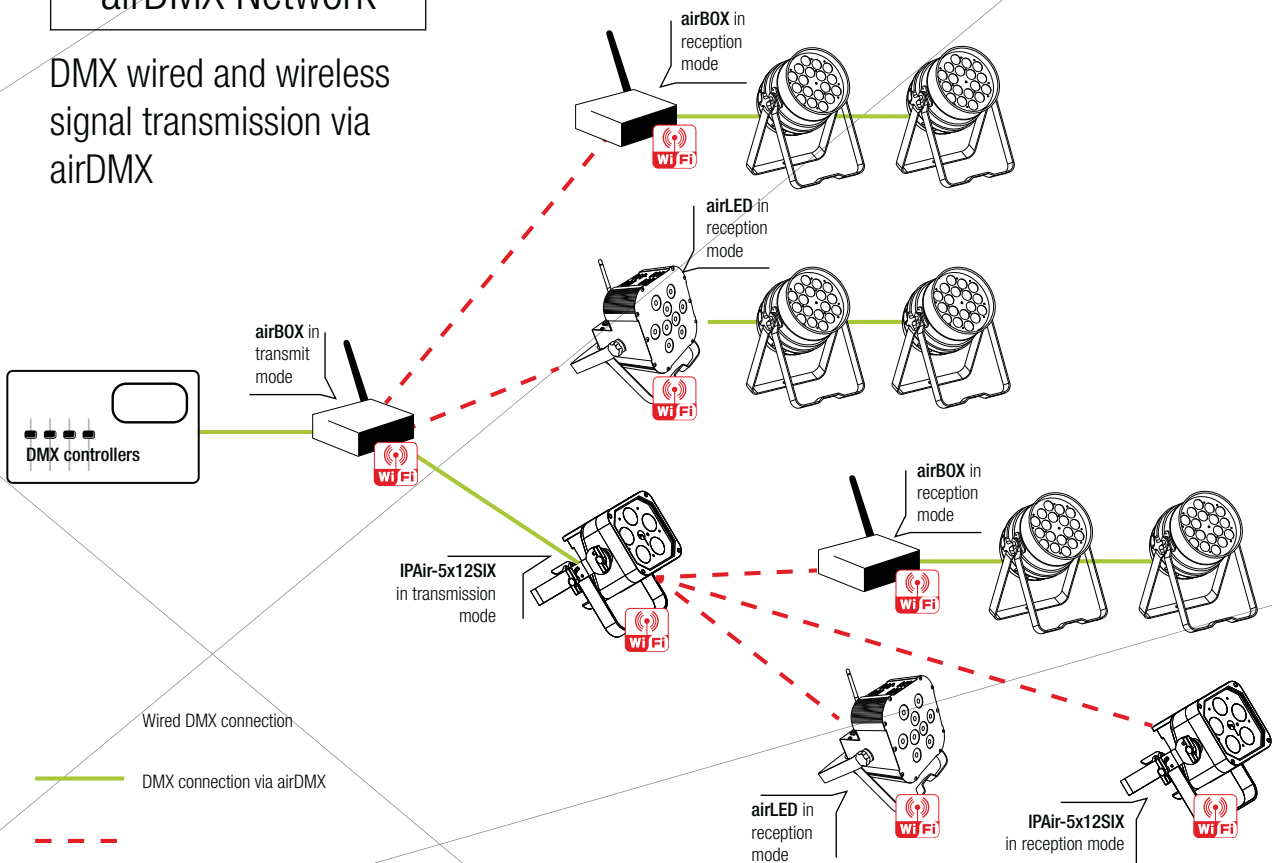

### VERY CONVENIENT, VERY FAST, VERY EFFICIENT, VERY AIRDMX

The airDMX system has been designed to simplify your nomad installations. Each airDMX compatible product can either act as an emission or a transmission device and broadcast an incoming DMX 512 wired signal into a Wi-Fi signal on its network. The 7 Wi-Fi frequencies available allow a perfect emission/reception over more than 100m\*.

\* Non-contractual informations, may differ due to usage conditions.



# airBOX-ER1-V1.3

Wireless DMX transmitter or receiver box

**Control without restraint**

ref 9966

- + airDMX in a compact format
- + Automatic transmission/reception
- + DMX512 - Wi-Fi with 7 frequencies



## RECEIVE AND TRANSMIT 512 DMX CHANNELS VIA WI-FI ON 7 FREQUENCIES.

The airBOX-ER1 allow you to transmit or receive the airDMX signal. As soon as it detects an incoming DMX wired signal the airBOX-ER1 automatically transmits it as a Wi-Fi DMX signal.

The removable attachment system allows you to easily install the airBOX-ER1 on a wall or on any suitable structure. The power socket can be used to link the airBOX-ER1 to other DMX projectors, or with both DMX and power connections.

## TECHNICAL SPECIFICATIONS

- airDMX Wi-Fi transmitter or receiver via 7 frequencies
- Average range of 100m in open space\*
- Frequency range: 2.400-2.483GHz ISM
- Select button with a tricolor light indicator
- 7 different channels allowing you to create several projector groups
- Power supply :
- 100/240 V - 50/60 Hz, AC
- Input/output power socket (up to 10 devices linked together for a maximum of 10 Amps)
- DMX input/output
- Maximum transmitting power : 20 dBm/100 mW
- Receiving sensibility: -94 dBm
- Metal housing
- Removable square edge to fix it on walls or on any suitable structure.
- Measurements : 165 x 120 x 53 mm
- Net weight : 0,5 kg



\* Non-contractual informations, may differ due to usage conditions.

# GAMME MINI LIGHT

Effets maximum  
pour un encombrement minimum\*

\*MINI LIGHT SERIES : Minimum size, maximal effects



by **Contest**<sup>®</sup>



# **MINI LIGHT SERIES**

# MINITRUSS

## 6TCb

6 x 3W RGB LEDs compact projector

**Proven efficacy in a new format**

ref 10365

**THE MINITRUSS-6TCB IS A COMPACT PROJECTOR BASED ON ONE WHICH HAS NOTHING LEFT TO PROVE.**

Specially designed to fit in any 290 mm triangular structure, it is also perfect for your mobile installations. You will surely enjoy its ease of use with a DMX controller and its many built-in colours and programs.

90

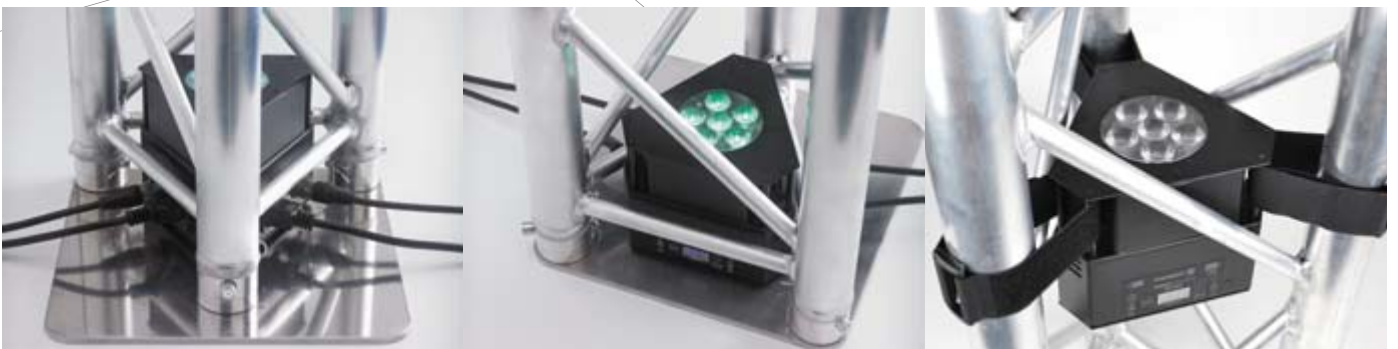

It comes with 4 straps fasteners allowing you to attach your projector to any structure, at all heights, in any position.



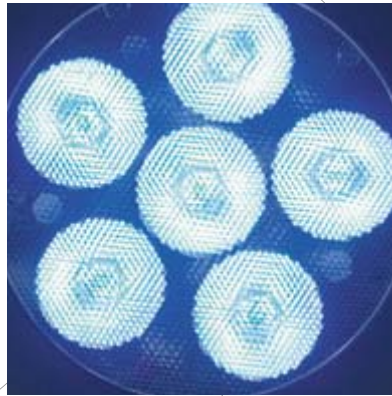

**ADVANCED FUNCTIONS**

The MINITRUSS-6TCb offers many different modes and adapt to any kind of installation. The DMX mode allows you to use 2 to 6 channels. The Auto mode gives you access to plenty of colour macros at variable speed, while the drop-down menu can be used to access other functions such as DMX and music-sensitive modes.

**HIGH PERFORMANCE LEDS**

With 6 x 3W trichromatic LEDs, the MINI-TRUSS-6TCb delivers a powerful, consistent light output.

**M8**

The M8 inserts located on the side and below the projector allow you to use hooks.



**DAISY-CHAINING**

The MINITRUSS-6TCb features power input and output sockets allowing you to daisy-chain more devices.

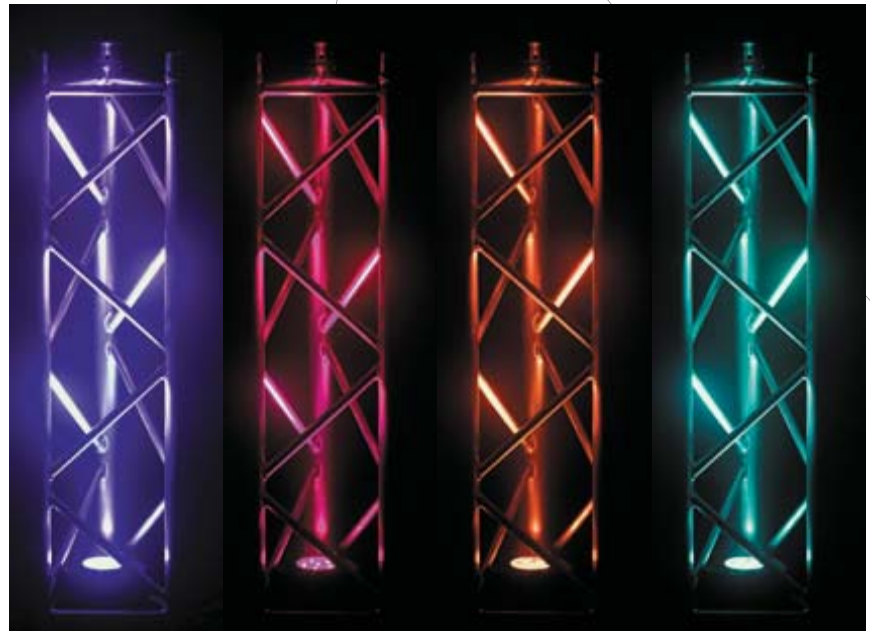

**TECHNICAL SPECIFICATIONS**

**LIGHT SOURCE**

- 3w 6 RGB LEDs
- LED: RGB 3-in-1
- Expected lifespan of 30.000 hours
- Low temperature, low power consumption, can be operated non-stop for many hours

**CONTROL**

- 2-6 DMX channels:
  - Individual colour control (R-G-B)
  - Dimmer
  - Strobe
  - Music-sensitive

**MODES**

- DMX
- Automatic
- Music-sensitive
- Master / Slave (Music-sensitive or automatic)

**OPTICAL**

Beamwidth: 30°

**ADDITIONAL CHARACTERISTICS**

- Power supply: 230V - 50Hz (input/output)
- Power consumption: 30 W
- Fuse: F1A
- Dimensions: 135 x 135 x 132 mm
- Net weight: 1.4 kg

# MINICUBE

## 6TCb









92

6x 3W TRI LEDs Compact projector  
**Colour concentrated**  
 ref 10147

### A TINY PROJECTOR WITH SO MANY POSSIBILITIES

The Minicube-6TCb features 6x3W trichromatic LEDs and produces a powerful light output with strong colours. It fits really well in both nomad and permanent installations and can be directed via a DMX controller or via the direct access to its many built-in programs and colours. Maximum power within an extremely compact projector.

#### TECHNICAL SPECIFICATIONS :

- |   |  |   |   |
|---|--|---|---|
| <br>6x3W RGB LEDs                  | <br>30° aperture angle  | <br>2-6 DMX channels               | <br>Auto |
| <br>Music-sensitive Maitre/Esclave | <br>Strobe              | <br>1 IEC 240 V 50 Hz input socket |          |
| <br>30 W                          | <br>165 x 180 x 110 mm | <br>1.350 kg                      |   |













# MINIBAR

RGB LEDs DMX Projector  
**Compact and powerful**  
 ref 10022



- + DMX, music-sensitive or auto modes
- + High performance lenses
- + Low power consumption

#### TECHNICAL SPECIFICATIONS :

- |   |  |   |  |  |   |
|---|--|---|--|--|---|
| <br>12x1W RGB LEDs | <br>30° aperture angle     | <br>3-5 DMX channels | <br>Auto              | <br>Music-sensitive | <br>Master/Slave |
| <br>Strobe         | <br>240V - 50Hz power cord | <br>20 W             | <br>295 x 78 x 110 mm | <br>1.5 kg          |   |











# TRI4U

4-projector bar with tricolor LEDs

**So small yet so versatile**

ref 9955

**TECHNICAL SPECIFICATIONS :**

|   |   |  |   |
|---|---|--|---|
| <br><b>LED</b><br>12x3W RGB LEDs | <br>25° aperture angle | <br><b>DMX</b><br>2-16 DMX channels | <br>Auto                           |
| <br>Music-sensitive              | <br>Master/Slave       | <br>Strobe                          | <br>1 IEC 240 V 50 Hz input socket |
| <br>50 W                         | <br>375 x 160 x 60 mm  | <br>2.5 kg                          |   |



- + 4 independent projectors within a light, compact housing
- + An incredible power and projection
- + Dynamic and easy-to-use built-in programs
- + An exclusive fastening system designed for light and speaker stand











# MINISET

4-projector lighting set

**It features 4 projectors, a stand, a footswitch and a transport bag**

ref 10201

**TECHNICAL SPECIFICATIONS :**

|   |   |  |   |
|---|---|--|---|
| <br><b>LED</b><br>12x9W RGB LEDs | <br>15° aperture angle | <br><b>DMX</b><br>3-15 DMX channels | <br>Auto                           |
| <br>Music-sensitive              | <br>Master/Slave       | <br>Strobe                          | <br>1 IEC 240 V 50 Hz input socket |
| <br>55 W                         | <br>910 x 242 x 50 mm  | <br>10 kg                           |   |



- + A whole set with many possibilities
- + DMX, music-sensitive or auto modes
- + The tricolor diodes offer outstanding colours
- + The footswitch makes things easier for you





Light performs

# LIVESET

La lumière est à vos pieds, pas les câbles\*

\*Light is a foot's reach, not cables

by **Contest**<sup>®</sup>





# LIVESET

4-projector bar with built-in strobes and wireless footswitch  
ref 10482

LIVESET features 4 projectors, for a total of 12 RGB LEDs and 9 Watts per LED, in addition to the 4 built-in strobes. It is entirely dedicated to stages, animation and colourful events.

It is the absolute projector to flood the room with colours wherever you use it stages, clubs, ambient lighting, thanks to its incredible colour rendering.











LIVESET features many built-in programs available both in automatic and manual modes, and an internal microphone for improved sound reactions.

And of course, all of its effects can be configured via DMX: fixed colours, strobe effects, colour variations or dynamic effects. You have full control over each RGB projector and the 4 strobe LEDs.

- + Rich colours
- + Projectors can be orientated
- + Wireless footswitch
- + 1 footswitch can control 2x LIVESET
- + Supplied with cover and stand



## TECHNICAL SPECIFICATIONS :

- |  |  |  |  |
|--|--|--|--|
| <br>12 LEDs<br>RGB 9W | <br>Aperture angle<br>15° | <br>1/4/18/19<br>channels | <br>Auto                            |
| <br>Musical           | <br>Master/Slave          | <br>4 LEDs<br>white 1W    | <br>Fiche IEC IN/OUT<br>240V - 50Hz |
| <br>108 W             | <br>910 x 242<br>x 50 mm  | <br>10 kg                 |  |

### TOTAL CONTROL AT THE TOUCH OF YOUR FOOT

Its footswitch benefits from the « WIFI » technology and allows you to remotely launch automatic or music-sensitive modes, fixed colours, black-out and also control two LIVESET with a single footswitch.

# 64 LEDs PAR

96

LED PAR64 DMX Projector











**It is more powerful than the LED-56 and projects lights on larger areas**



**LED-64RGB-SH-SI**  
Finishing : Aluminium  
ref 8977

**LED-64RGB-SH-BL**  
Finishing : Satin black  
ref 9366

**TECHNICAL SPECIFICATIONS :**

-  **LED**  
181 RGB LEDs Aperture angle 30°
-  Aperture angle 30°
-  **DMX**  
4 channels
-  **Auto**
-  Music-sensitive
-  Master/Slave
-  Strobe
-  240V  
50 Hz power cord
-  30 W
-  300 x 220 x 230 mm
-  2.3 kg

# 56 LEDs PAR

LED PAR56 DMX Projector











**The perfect projector for ambient lighting and small stages**



**LED-56RGB-SH-SI**  
Finishing : Aluminium  
ref 9054

**LED-56RGB-SH-BL**  
Finishing : Satin black  
ref 9362

**TECHNICAL SPECIFICATIONS :**

-  **LED**  
109 RGB LEDs Aperture angle 30°
-  Aperture angle 30°
-  **DMX**  
4 channels
-  **Auto**
-  Music-sensitive
-  Master/Slave
-  Strobe
-  240V - 50 Hz  
power cord
-  18 W
-  274 x 232 x 205 mm
-  1.8 kg

# 38 LEDs PAR

LED PAR38 DMX Projector











**Small size, Great performances**



**LED-38RGB-SI**  
Finishing : Aluminium  
ref 9052

**LED-38RGB-BL**  
Finishing : Satin black  
ref 9359

**TECHNICAL SPECIFICATIONS :**

-  **LED**  
75 RGB LEDs Aperture angle 30°
-  Aperture angle 30°
-  **DMX**  
4 channels
-  **Auto**
-  Music-sensitive
-  Master/Slave
-  Strobe
-  240V - 50 Hz  
power cord
-  9 W
-  180 x 154 x 135 mm
-  1 kg

# 36 LEDs PAR

LED PAR36 DMX Projector

**This very vintage LED projector will reinvent your home's interior**



**LED-36RGB-SI**  
Finishing : Aluminium  
ref 9357

**LED-36RGB-BL**  
Finishing : Satin black  
ref 9355

**TECHNICAL SPECIFICATIONS :**

-  **LED**  
56 RGB LEDs Aperture angle 30°
-  Aperture angle 30°
-  **DMX**  
4 channels
-  **Auto**
-  Music-sensitive
-  Master/Slave
-  Strobe
-  240V - 50 Hz  
power cord
-  Strobe
-  8 W
-  195 x 154 x 115 mm
-  1.2 kg



Light performers / LED PAR Projectors

# GAMME LIGHT DJ

Sortez de l'ombre\*

\*LIGHT DJ SERIES : Emerge from the shadows



by **Contest**<sup>®</sup>



NEW



# GOBOBEAM

Animation effect with 8 x 3W LEDs and moving gobos projection  
ref 10662

- + Flower « Gobos »
- + RGBA source
- + Ultra-bright multi-beam



## TECHNICAL SPECIFICATIONS :

|                                   |                                  |        |                               |
|-----------------------------------|----------------------------------|--------|-------------------------------|
| <b>LED</b><br>8 x 3W<br>RGBA LEDs | <b>DMX</b><br>1-8/12<br>channels | Auto   | Music-sensitive               |
| Master/Slave                      | Strobe                           | Easy 2 | 1 Fiche IEC IN<br>240V - 50Hz |
| 40 W                              | 290 x 160<br>x 200 mm            | 3 kg   |                               |

NEW



# TRIP TIC

Animation effect Wash, Beam and Flash  
ref 10650

- + 3-in-1 effect
- + Colour macros
- + Beam, Wash and Flash



## TECHNICAL SPECIFICATIONS :

|  |  |                       |                                     |
|--|--|-----------------------|-------------------------------------|
| <b>LED</b><br>Wash<br>3x3W LEDs<br>4 en 1 RGBW | <b>LED</b><br>Beam<br>84 LEDs - 75mW<br>8R-8A-6B-6G (x3) | 12x0,5W<br>Flash LEDs | <b>DMX</b><br>1/3/10/21<br>channels |
| Auto   | Music-sensitive  | Master/Slave          | 2,8 kg                              |
| 1 Fiche IEC IN<br>240V - 50Hz                  | 61 W   | 325 x 300 x<br>270 mm |                                     |











## NIGHTCOLOR

Wash projector 3 LEDs 1W RGB  
 ref 10648

### TECHNICAL SPECIFICATIONS :



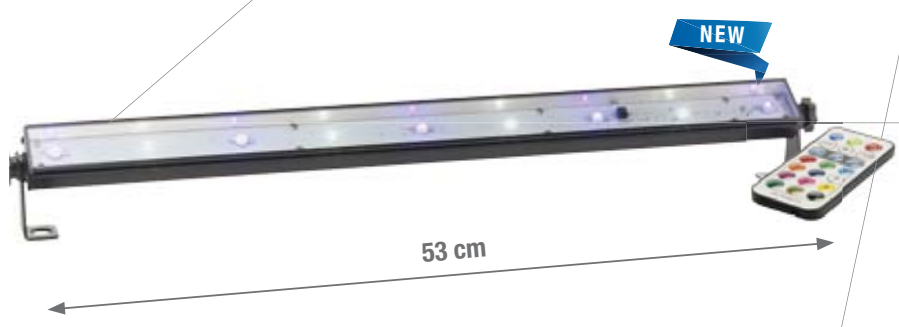





-  **LED**  
3x1W LED  
1R 1G 1B
-  **Auto**
-  **Music-sensitive**
-  **5 W**
-  **190 x 60  
x 110 mm**
-  **0,55 kg**
-  **240 V - 50 Hz  
12V DC supplied  
adapter**



## NIGHTFLUO

Lighting bar with 5 UV LEDs and 4 Flash LEDs  
 ref 10649

### TECHNICAL SPECIFICATIONS :

-  **LED**  
5 UV LEDs
-  **4 LEDs Flash**
-  **Auto**
-  **Music-sensitive**
-  **0,245 kg**
-  **12 W**
-  **530 x 40  
x 60 mm**
-  **240 V - 50 Hz  
12V DC supplied  
adapter**









## NIGHTBALL

Half-dome with 3 RGB 1W LEDs  
 ref 10711



### TECHNICAL SPECIFICATIONS :

-  **LED**  
3 x 1W RGB  
LED
-  **Auto**
-  **Music-sensitive**
-  **0,195 kg**
-  **5 W**
-  **125 x 105  
x 120 mm**
-  **240 V - 50Hz  
12V DC  
supplied  
adapter**







**NEW**

100



16 cm

**TECHNICAL SPECIFICATIONS :**

-  **LED**  
1 x 9W RGB LED
-  **Auto**
-  **Music-sensitive**
-  **10 W**
-  **180 x 160 x 190 mm**
-  **240 V - 50 Hz  
12V DC supplied adapter**
-  **0,950 kg**

# NIGHT FLOWER

Flower-like animation effect with 9W RGB LEDs  
 ref 10646









**NEW**



16 cm

**TECHNICAL SPECIFICATIONS :**

-  **LED**  
3x3W RGB LEDs
-  **Auto**
-  **Music-sensitive**
-  **10 W**
-  **180 x 160 x 190 mm**
-  **240 V - 50 Hz  
12V DC supplied adapter**
-  **0,950 kg**

# NIGHT MOTION

Mushroom-like animation effect with 3x3W RGB LEDs  
 ref 10645









**NEW**



18 cm

**TECHNICAL SPECIFICATIONS :**

-  **LED**  
3x3W RGB LEDs
-  **Auto**
-  **Music-sensitive**
-  **10 W**
-  **180 x 160 x 200 mm**
-  **240 V - 50 Hz  
12V DC supplied adapter**
-  **0,950 kg**

# NIGHT DERBY

Derby animation effect with 3 RGB LEDs  
 ref 10647















# NIGHT FURY

Animation effect with RGBWA LEDs + White Flash  
 REF 10530

- + Super-powerful and large beams
- + Stunning flash effect
- + Infrared remote control supplied



### TECHNICAL SPECIFICATIONS :

-  **LED**  
20x3W RGBWA LEDs
-  **DMX**  
1/3/10 channels
-  **Auto**
-  **Music-sensitive**
-  **Master/Slave**
-  **12x1W Flash LEDs**
-  **3,6 kg**
-  **1 Fiche IEC IN 240V - 50Hz**
-  **66 W**
-  **294 x 173 x 294 mm**











# OCTO DANGLE

Animation effect with RGBWA LEDs + RGBWUV flash  
 REF 10531

- + Very wide multi-beam projections
- + Many different modes
- + Powerful colours flashes



### TECHNICAL SPECIFICATIONS :

-  **LED**  
5x3W RGBWA LEDs
-  **DMX**  
1-7 channels
-  **Auto**
-  **Music-sensitive**
-  **Master/Slave**
-  **8x2W LEDs**  
2xR/UV, 2xG/UV  
2xB/UV, 2xW/UV
-  **4,2 kg**
-  **1 Fiche IEC IN 240V - 50Hz**
-  **66 W**
-  **313 x 169 x 246 mm**



# FLASHBEAM

Projecteur bar with 9W Tri LEDs and 4 white flash LEDs  
 ref 10481

102

FLASHBEAM features 8 RGB LEDs of 9 Watts each, and that is why it is one of the most comprehensive Light DJ effects.

The last generation of multi-beam effect gave birth to FLASHBEAM, which creates stunning animations thanks to its double projector ramp equipped with fully adjustable projectors.



- + Wide coverage area
- + Multibeam effect
- + Projectors can be manually adjusted
- + Built-in strobe
- + Music-sensitive functions
- + DMX Compatible

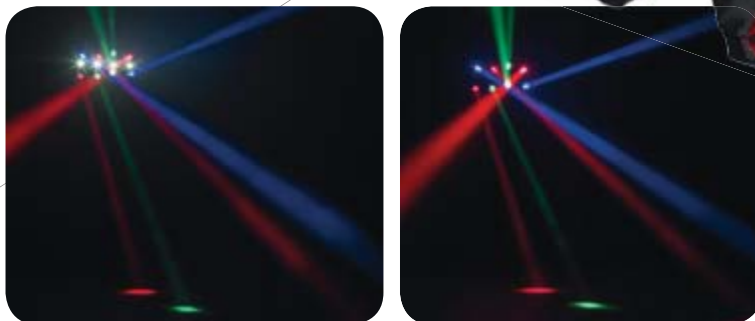

# HEXABEAM

The multifaceted rotational beam effect  
 ref 10364

Spectacular, colourful multibeam projections. The HEXABEAM features a super-powerful 32W Quad-colour LED, making it one of the most powerful Light DJ effects of its category.

An incredible optical system producing several 5° beams, colourful and astonishing animations: the HEXABEAM really is part of the latest generation of multibeam effects.













It is so adaptable you can either use it as centerpiece style effect or control several HEXABEAM in Master/Slave mode via the Easy-2 remote control.

Its exclusive internal program proves it to be formidably efficient when it comes to music-sensitive effects.



- + 1 x 32 W Quad-colour LED
- + Non-stop rotation
- + Ultra shiny and narrow beams
- + Plug 'n Play
- + Easy-2 compatible

## TECHNICAL SPECIFICATIONS :

- |  |   |   |   |
|--|---|---|---|
| <br>32 RGBW LED                   | <br>1-4 channels | <br>5° Aperture          | <br>Auto   |
| <br>Music-sensitive               | <br>Master/Slave | <br>Strobe               | <br>Easy 2 |
| <br>1 Fiche IEC IN<br>240V - 50Hz | <br>43 W         | <br>350 x 352<br>x 203mm | <br>4,6 kg |





# QUADROLL

8W RGBW LEDs roller effect  
ref 10290



## TECHNICAL SPECIFICATIONS :

- LED**  
8 W  
R/G/B/W
- DMX**  
1/3/10/14  
channels
- Auto**
- Music-sensitive**
- Master/Slave**
- Strobe**
- Easy 2**
- 240V - 50 Hz  
IEC power  
input**
- 40 W**
- 479 x 247  
x 132 mm**
- 2,2 kg**

- + 4x8W Red/Green/Blue/White LEDs
- + Crossed-light and rotating beam effects
- + Very wide aperture angle



103

# LED BEAMER

The 2x9W tricolor LEDs create a powerful multi-beam ideal for animation effects  
**New effects with a powerful moving multi-beam technology**  
ref 10023



## TECHNICAL SPECIFICATIONS :

- LED**  
2x9W RGB  
LEDs
- Auto**
- Music-sensitive**
- Strobe**
- Power cord  
with a 240V -  
50Hz plug**
- 20 W**
- 310 x 205  
x 310 mm**
- 3,4 kg**

- + Ultra-bright multi-beam
- + Music-sensitive synchronisation
- + Very easy to use



# DELIRIUM

The 320 RGBW LEDs create many unparalleled multi-beam effects  
**Many built-in programs, unlimited ultra-dynamic effects**



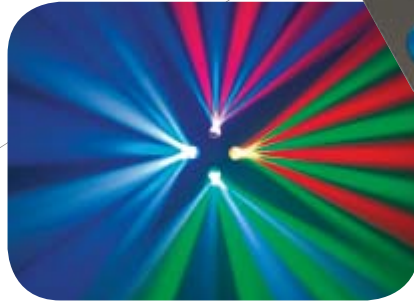
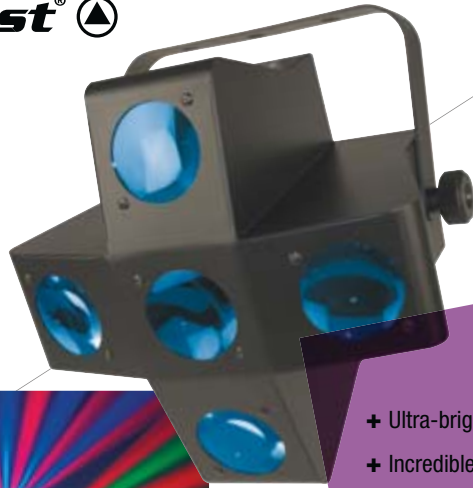







ref 9893



- + Ultra-bright multi-beam
- + Incredible, varied animations
- + Advanced music-sensitive synchronisation

## TECHNICAL SPECIFICATIONS :

104













- |   |  |  |  |
|---|--|--|--|
|  <b>LED</b><br>320 LEDs<br>R/G/B/W |  <b>DMX</b><br>4 channels |  <b>Auto</b>                                  |  <b>Music-sensitive</b> |
|  <b>Master/Slave</b>               |  <b>Strobe</b>            |  <b>1 IEC IN</b><br>240V - 50Hz<br>input plug |  <b>27 W</b>            |
|  <b>309 x 309</b><br>x 227 mm      |  <b>3.8 kg</b>            |  |  |

# LED-GUN

LED RGBW 10W Multi-beam animation effects  
**Hundreds of ultra-thin laser-like beams**  
 ref 9541



## TECHNICAL SPECIFICATIONS :

- |  |  |  |   |
|--|--|--|---|
|  <b>LED</b><br>1x10W RGBW<br>LED              |  <b>DMX</b><br>4-7 channels |  <b>65°</b><br>aperture       |  <b>Auto</b>   |
|  <b>Music-sensitive</b>                       |  <b>Master/Slave</b>        |  <b>Strobe</b>                |  <b>Easy 2</b> |
|  <b>1 IEC IN</b><br>240V - 50Hz<br>input plug |  <b>12.5 W</b>              |  <b>271 x 176</b><br>x 213 mm |  <b>3 kg</b>   |











- + Laser-like effects
- + Auto, DMX or music-sensitive modes
- + Compatible with the EASY-2 remote control



# LED-BLASTER

2x10W RGBW LEDs multi-beam animation effects  
**Flood the room with incredible multicoloured beams**  
 ref 9915

## TECHNICAL SPECIFICATIONS :

- |  |  |   |  |
|--|--|---|--|
|  <b>LED</b><br>2 LEDs<br>RGBW 10W |  <b>DMX</b><br>1-3 canaux     |  <b>Auto</b>   |  <b>Music-sensitive</b>                     |
|  <b>Master/Slave</b>              |  <b>Strobe</b>                |  <b>Easy 2</b> |  <b>1 IEC IN/OUT</b><br>240V - 50Hz<br>plug |
|  <b>34 W</b>                      |  <b>296 x 271</b><br>x 140 mm |  <b>3.8 kg</b> |  |



- + Colourful, moving multi-beam
- + Very wide angle
- + Ultra-dynamic strobe
- + EASY-2 Compatible













# LED-UV12

UV Projector  
 ref 10288



**TECHNICAL SPECIFICATIONS :**

-  **LED**  
12x3W UV LEDs
-  **Aperture angle: 60°**
-  **DMX**  
2 channels
-  **Music-sensitive**
-  **Master/Slave**
-  **Strobe**
-  **240V - 50 Hz IEC IN/ OUT power socket**
-  **35 W**
-  **295x 228 x 118 mm**
-  **2.2 kg**

- + Wide aperture angle
- + Convection cooling system
- + Compact size
- + 2 DMX channels

- + Real UV effects
- + Super wide angle
- + Compact metal housing









# LED-UV8

UV LED Projector  
**The legend's rebirth**  
 ref 9956



**TECHNICAL SPECIFICATIONS :**

-  **LED**  
8x1W UV LEDs
-  **65° aperture**
-  **Power cord with a 240V - 50Hz plug**
-  **15 W**
-  **160 x 80 x 60 mm**
-  **0.950 kg**







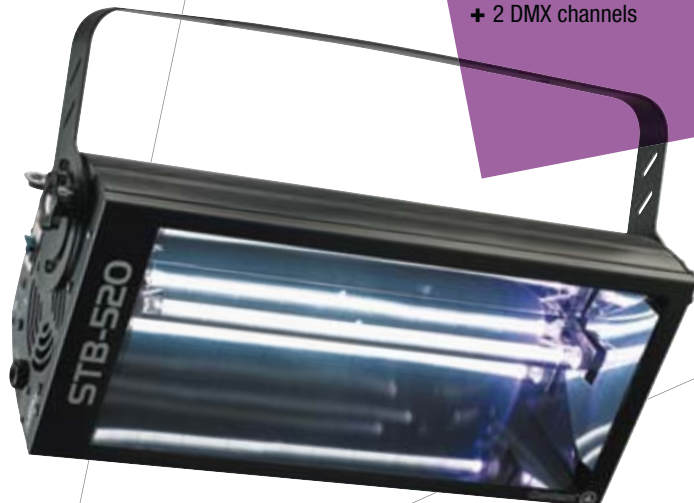



- + Large aluminium reflector
- + 1500 W
- + Auto and music-sensitive modes
- + 2 DMX channels

# STB-520

1500W Lamp stroboscope  
**Tremendous power, incredible speed**  
 ref 7122



**TECHNICAL SPECIFICATIONS :**

-  **LAMPE**  
1500W Xenon lamp
-  **DMX**  
2 channels
-  **Auto**
-  **Music-sensitive**
-  **Master/Slave**
-  **Strobe**
-  **Power cord with a 240V - 50Hz plug**
-  **1500 W**
-  **455 x 205 x 137 mm**
-  **5.2 kg**



sfx  
scenogrofx

# Une nouvelle gamme pour sublimer vos mises en scène\*

\* A new series to transcend your creations



SCENE

STORE

EXPO

# SCENOGRAFX SERIES



« A scenographer brings together volumes, objects, colours, lighting and textures ».

The concept of « scenography » can be divided into three categories:

- The « stage scenographer », who brings to life a spectacle, or a show.
- The « equipment scenographer », who designs a place in order to host shows or various spectacles.
- The « exhibition scenographer », who is particularly involved in museums and exhibitions.

## SCENE / STORE

### EQUIPMENT FOR PERMANENT OR TEMPORARY EXHIBITIONS

High performances, a very long life span and low power consumption allow the LED source to integrate compact, effective projectors, without compromising on aesthetic. They know how to highlight any kind of place or surface, while respecting the illuminated subjects.

ScenograFX projectors allow to emphasize the curves of an artwork, and bring the colours out of graphic works during temporary or permanent exhibitions.

They are also perfect to present the products from your showcase or exhibition stand in their best possible light.



## EXPO

### STAGE EQUIPMENT FOR LIVE SHOWS

Our ScenograFX series products are affordable and easy-to-install, which makes them perfect lighting solutions to highlight your events.

These projectors deliver the same light and gradation quality than filament lampsquality, thanks to its built-in dimmer modes.

LED sources bring to the table a new flexibility, and really is an interesting option. In fact, this new generation of projectors does not require any dimmer, which means less maintenance and simplified installations.

## LED LIGHT SOURCES

LED light sources bring new solutions on many levels, nowadays LEDs are used for stage, architectural and event lighting.

Building on the success of its animation projectors, Contest® keeps going in the same direction with the creation of a brand new projector series designed to produce an incredible light output, with first-class optical quality and ergonomics.





# SFX-H0150W

Horiziode asymmetrical

**Horiziode asymmetrical LED COB projector 150W white source**

ref 10702



- + LED COB 150W warm white
- + Asymmetrical projection
- + Large aperture angle

108

**NEW**

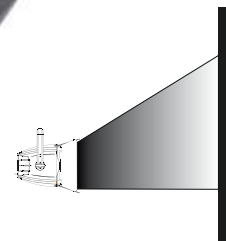

Asymmetrical projection

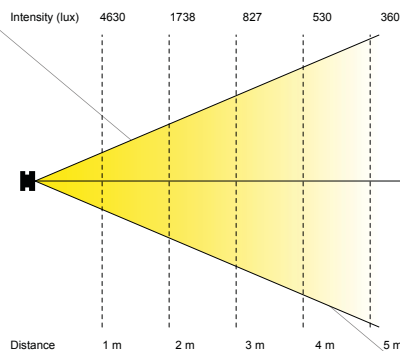
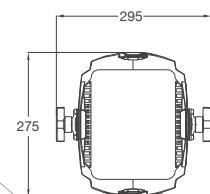
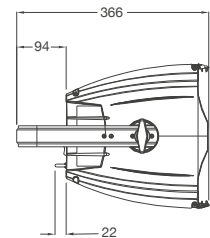
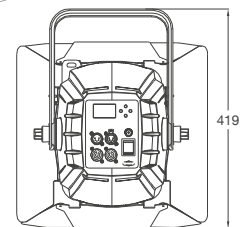

## TECHNICAL SPECIFICATIONS

### • FUNCTIONS:

- Built-in command panel with LCD drop-down display to:
- Select the DMX address
- Select the number of channels: 1 or 2
- Select dimmer modes and speed
- Strobe at adjustable speed

### • OPTICAL:

- 1 X 150W COB WARM WHITE (3200°K) LED
- CRI > 92
- Light output of 530 Lux at 4m
- Aperture angle: 90°X113°

### • CONNECTIONS:

- DMX IN and OUT via 3-pin XLR,
- POWER IN/OUT via powerCON socket
- Power supply: 100-240V/50-60Hz
- Power consumption: 155 W
- Cooling system: Cooler cell system with heat dissipater and silent fan
- Finish: Black
- Accessories: supplied with adjustable shutters, filter support, double fixation bracket and power cord powerCON
- Dimensions: 295 x 315 x 377 mm
- Weight: 6,2 kg





# SFX-H0150QC

Horiziode asymmetrical

**Horiziode asymmetrical LED COB projector 4-in-1 RGBW 150W source**

ref 10701



- + LED COB 150W RGBW
- + No fan
- + Asymmetrical projection
- + Large aperture angle

109

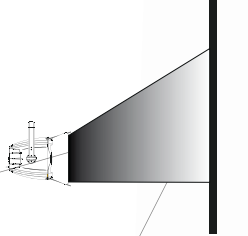

Asymmetrical projection

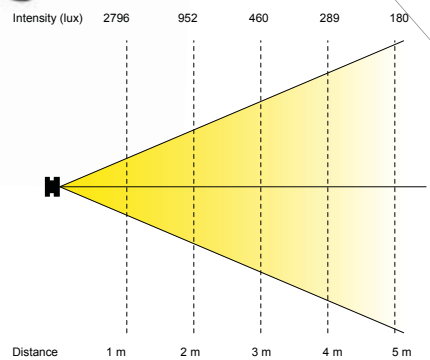
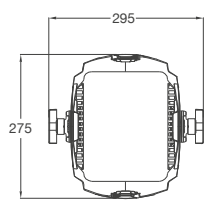
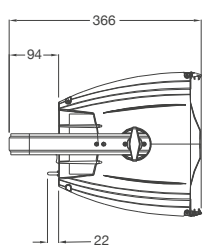
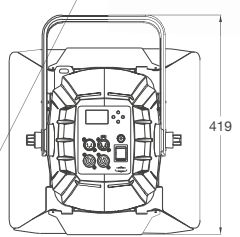

## TECHNICAL SPECIFICATIONS

### • FUNCTIONS:

- Built-in command panel with LCD drop-down display to:
  - Select the DMX address
  - Select the number of channels: 1, 4, 6 or 8
  - Select dimmer modes and speed
  - Virtual colour wheel with 24 presets
  - 7 macros with speed settings and music-sensitive mode
  - Strobe at adjustable speed

### • OPTICAL:

- 1 x 150W RGBW COB LED
- LIGHT OUTPUT OF 289 LUX AT 4M
- Colour temperature from 2800°K to 6000°K

- Aperture angle: 90°X113°

### • CONNECTIONS:

- DMX IN and OUT via 3-pin XLR,
- POWER IN/OUT via powerCON socket
- Power supply: 100-240V/50-60Hz
- Power consumption: 155 W
- Cooling system: Cooler cell system with heat dissipater and silent fan
- Finish: Black
- Accessories: supplied with adjustable shutters, filter support, double fixation bracket and power cord powerCON
- Dimensions: 295 x 315 x 377 mm
- Weight: 6,2 kg



# SFX-FR250W

Fresnel projector

**Fresnel projector with 250W white LED COB and motorized ZOOM**

ref 10707



- + LED COB 250W warm white
- + Quiet projector
- + CRI >90
- + Motorized zoom from 15° to 45°
- + Direct and simultaneous access to both dimmer and motorized zoom via DMX.

110

**NEW**

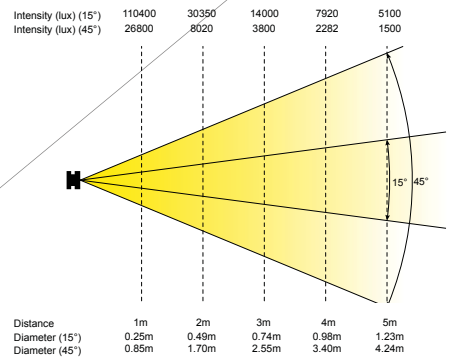

## TECHNICAL SPECIFICATIONS

### • FUNCTIONS:

- Direct access to manual Zoom
- Built-in command panel with drop-down LCD display to:
  - Select the DMX address
  - Select the number of channels: 2 or 3
  - Select the dimmer curve
  - Access to hour counter, temperature, and software information
  - Test and calibration Mode

### • OPTICAL:

- 1 x 250W Warm White (3200°K) COB LED
- CRI > 90
- Light output from 2280 - 7900 Lux at 4m

- Aperture angle via motorized zoom from 15° - 45°

### • CONNECTIONS:

- DMX IN and OUT via 3 and 5-pin XLR,
- POWER IN/OUT via powerCON socket
- Power supply: 100-240V/50-60Hz
- Power consumption: 275 W
- Cooling system: heat dissipater and silent fan
- Finish: Black
- Accessories: supplied with adjustable shutters, filter support, fixation bracket and power cord powerCON
- Dimensions: 458 x 336 x 399 mm
- Weight: 8,9 kg

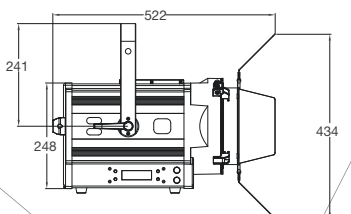
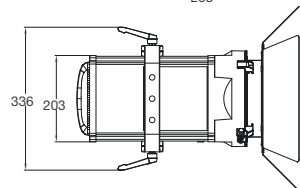
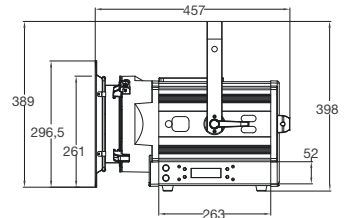



# SFX-FR150W

Fresnel projector

**Fresnel projector with 150W white LED COB and motorized ZOOM**

ref 10708



- + LED COB 150W warm white
- + Quiet projector
- + CRI >90
- + Motorized zoom from 15° to 45°
- + Direct and simultaneous access to both dimmer and motorized zoom via DMX.

**NEW**



111

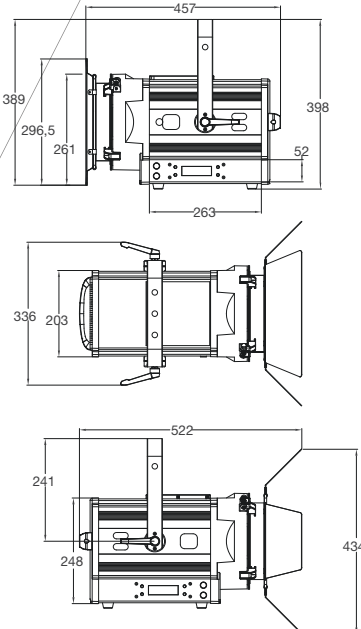
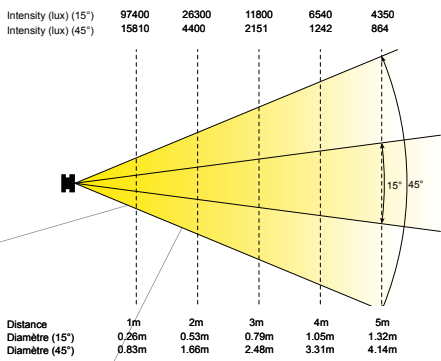

## TECHNICAL SPECIFICATIONS

• **FUNCTIONS:**

- Direct access to manual Zoom
- Built-in command panel with drop-down LCD display to:
  - Select the DMX address
  - Select the number of channels: 2 or 3
  - Select the dimmer curve
- Access to hour counter, temperature, and software information
- Test and calibration Mode

• **OPTICAL:**

- 1 x 150W Warm White (3200°K) COB LED
- CRI > 90
- Light output from 1242 - 6540 Lux at 4m

- Aperture angle via motorized zoom from 15° - 45°

• **CONNECTIONS:**

- DMX IN and OUT via 3 and 5-pin XLR,
- POWER IN/OUT via powerCON socket
- Power supply: 100-240V/50-60Hz
- Power consumption: 180 W
- Cooling system: heat dissipater and silent fan
- Finish: Black
- Accessories: supplied with adjustable shutters, filter support, fixation bracket and power cord powerCON
- Dimensions: 458 x 336 x 399 mm
- Weight: 8,9 kg





# SFX-PC60QC

Plano-convex

Plano-convex projector with 60W 4-in-1 RGBW LED COB and manual ZOOM



+ LED COB 60W 4-in-1 RGBW  
 + Built-in colour presets  
 + Manual zoom from 20° to 45°

112

## SFX-PC60QCb

Finishing : black  
 ref 10705

## SFX-PC60QCw

Finishing : white  
 ref 10706



|                       |       |       |       |       |       |
|-----------------------|-------|-------|-------|-------|-------|
| Intensity (lux) (20°) | 13500 | 3875  | 1871  | 1128  | 760   |
| Intensity (lux) (45°) | 2080  | 549   | 252   | 142   | 94.7  |
| Distance              | 1m    | 2m    | 3m    | 4m    | 5m    |
| Diameter (20°)        | 0.37m | 0.74m | 1.11m | 1.48m | 1.85m |
| Diameter (45°)        | 0.85m | 1.70m | 2.55m | 3.40m | 4.24m |

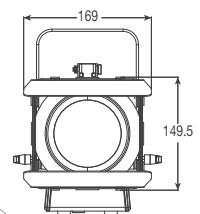
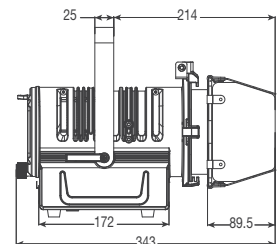
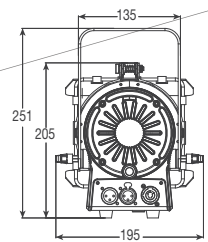

### TECHNICAL SPECIFICATIONS

• **FUNCTIONS:**

- Direct access to manual Zoom
- Built-in command panel with drop-down LCD display to:
  - Select the DMX address
  - Select the number of channels: 1, 4, 6 or 8
  - Select the dimmer curve
  - Access to hour counter, temperature, and software information
  - COLOR Mode

• **OPTICAL:**

- 1 x 60W COB RGBW LED
- Colour temperature from 2800°K to 6000°K
- Light output from 250 to 1870 Lux at 3m

- Aperture angle via manual zoom from 20° to 45°

• **CONNECTIONS:**

- DMX IN and OUT via 3-pin XLR,
- POWER IN via powerCON socket
- Power supply: 100-240V/50-60Hz
- Power consumption: 70 W
- Cooling system: forced ventilation
- Finish: Black
- Accessories: supplied with adjustable shutters, filter support, fixation bracket and power cord powerCON
- Dimensions: 241 x 196 x 173 mm
- Weight: 3,6 kg



# SFX-PC50W

Plano-convex projector

Plano-convex projector with 50W white LED COB and manual ZOOM



- + LED COB 50W warm white
- + Quiet projector
- + CRI >90
- + Manual zoom from 20° to 45°



113

## SFX-PC50Ww

Finishing : white  
ref 10704

## SFX-PC50Wb

Finishing : black  
ref 10703



|                       |       |      |      |      |     |
|-----------------------|-------|------|------|------|-----|
| Intensity (lux) (20°) | 19500 | 5000 | 2200 | 1217 | 788 |
| Intensity (lux) (45°) | 3535  | 959  | 440  | 252  | 170 |

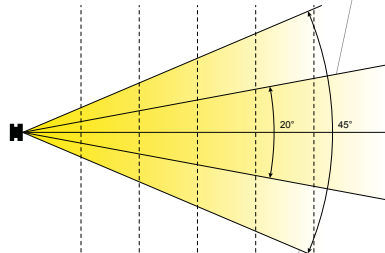

|                |       |       |       |       |       |
|----------------|-------|-------|-------|-------|-------|
| Distance       | 1m    | 2m    | 3m    | 4m    | 5m    |
| Diameter (20°) | 0.37m | 0.74m | 1.11m | 1.48m | 1.85m |
| Diameter (45°) | 0.85m | 1.70m | 2.55m | 3.40m | 4.24m |

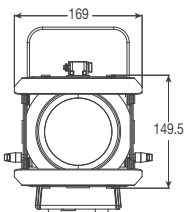
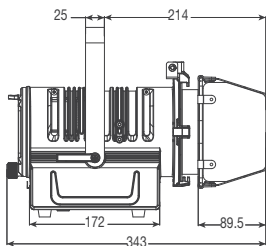
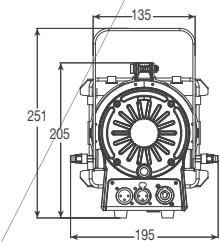

### TECHNICAL SPECIFICATIONS

**FUNCTIONS:**

- Direct access to manual Zoom
- Built-in command panel with drop-down LCD display to:
  - Select the DMX address
  - Select the number of channels: 1 or 2
  - Select the dimmer curve
  - Access to hour counter, temperature, and software information
  - Test Mode

**OPTICAL:**

- 1 x 50W COB Warm White (3200°K) LED
- CRI > 90
- Light output from 440 - 2200 Lux at 3m

- Aperture angle via manual zoom from 20° - 45°

**CONNECTIONS:**

- DMX IN and OUT via 3-pin XLR,
- POWER IN via Powercon socket
- Power supply: 100-240V/50-60Hz
- Power consumption: 55 W
- Cooling system: heat dissipater without forced ventilation
- Finish: Black
- Accessories: supplied with adjustable shutters, filter support, fixation bracket and power cord powerCON
- Dimensions: 241 x 196 x 173 mm
- Weight: 3,6 kg

# NOUVELLE SFX-DE40W

La lumière taillée sur-mesure\*

\*Tailor-made lighting







# SFX-DE40W

Profile spot

**Profile spot with 40W white LED and gobo support**

code 10700



Our SFX-DE40W is a « profile spot », equipped with a 40W COB LED reaching a colour temperature of 3200°K (Warm white). Its cast-aluminium body, beside aesthetics considerations, allows thermal dissipation using natural convection, and thus total silence.

The four blades combined with a gobo support are perfect to highlight works of art in quiet places, thanks to sharp and precise lighting.

**NEW**



- + LED COB 40W warm white
- + No fan
- + Gobo support
- + Manual focus
- + Dimmer via control knob

115

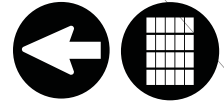
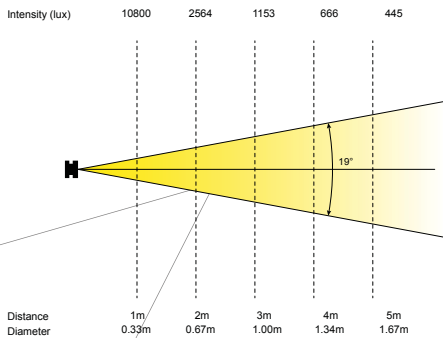

Supplied with 2 gobos



## TECHNICAL SPECIFICATIONS

### • FUNCTIONS:

- Blades shape the beam
- Electronic dimmer
- Manual focus control
- Gobo support (external diam 34mm, image 24mm)

### • OPTICAL:

- 1 x 40W white COB LED
- Colour temperature : 3200°K
- CRI 95
- Light output of 1150 Lux at 3m
- Beam angle of 19°

### • CONNECTIONS:

- POWER IN via 2P+E socket

- Power supply: 100-240V/50-60Hz
- Power consumption: 40 W
- Cooling system: convection-cooled, without forced ventilation
- Finish: Black die-cast aluminium body
- Accessories: supplied with fixation bracket, gobo support + 2 gobos
- Dimensions: 273 x 111 x 100 mm
- Weight: 1,2 kg

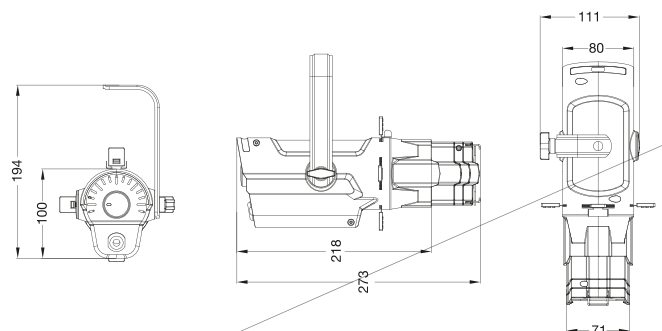



# **CONTEST ARCHITECTURE**

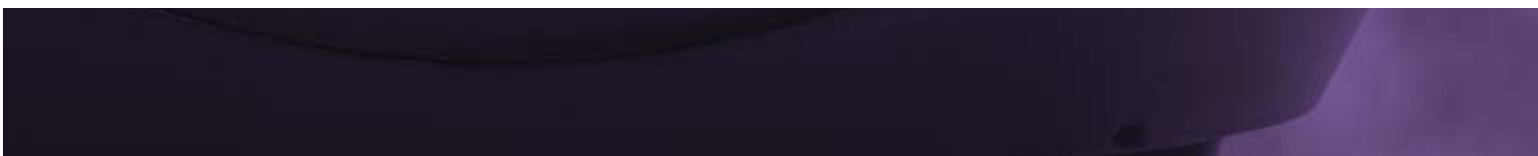

# IPFLOOD5x15QC

Le projecteur qui s'expose aux éclats sans dégâts\*

\*Getting exposed and always glows



by **Contest**<sup>®</sup>



# IPFLOOD 5x15QC

Outdoor IP65 wireless and battery-operated projector

**Fully weather-resistant**

ref 10263

118

Its IP65 aluminium housing and safety glass make it as good indoor as outdoor. The lithium-ion battery works up to 7 hours at full power, and up to 17 hours with colour changing.

The IPFLOOD5x15QC is a 5x15 quadricolor OSRAM<sup>®</sup> LEDs independent high-efficiency independent projector. It is fully orientable and produces 5,800 lux at 3m meters. It is perfect for ambient and architectural lighting. In addition to its super-powerful light output, it comes with a removable frost filter to switch from a 17° to a 43° angle in a flash.



- + 5x15 Quadricolour OSRAM<sup>®</sup> LEDs
- + Lithium-ion battery
- + Wireless DMX
- + Very resistant weatherproof housing

IPFLOOD5x15QC with Frost filter

## OPTIONS

### IPFLOOD-POW

You will require this external power supply unit to charge your projector battery

ref 10287



### FLY-IPFLOOD-S1

Charging flight case for 6 IPFLOOD-5x15QC

ref 10264

This flight case has been specially designed to easily charge and transport 6 IPFLOOD5x15QC projectors.





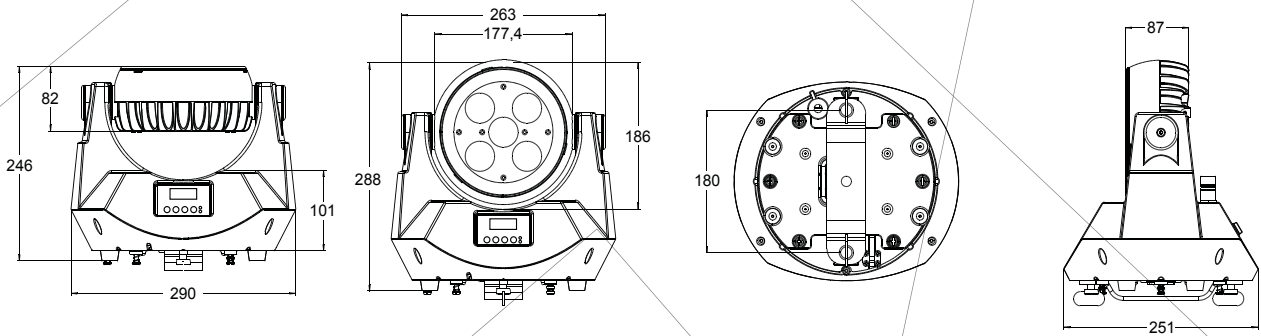

Built-in wireless DMX receiver and transmitter, WDMX-ERIP compatible



|                       |       |      |      |
|-----------------------|-------|------|------|
| Intensity (lux) (17°) | 2572  | 1140 | 637  |
| Intensity (lux) (9°)  | 12960 | 5810 | 3253 |

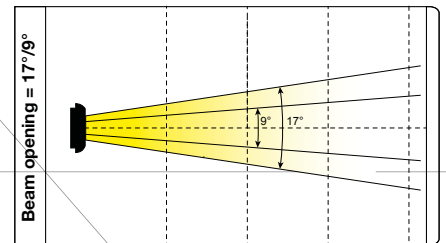

|                    |        |        |        |
|--------------------|--------|--------|--------|
| Distance (m)       | 2      | 3      | 4      |
| Diameter (m) (9°)  | Ø 0,61 | Ø 0,91 | Ø 1,22 |
| Diameter (m) (17°) | Ø 1,57 | Ø 2,35 | Ø 3,14 |

## TECHNICAL SPECIFICATIONS

### OPTICAL

- 5x15W quadricolor LEDs (50,000 hours)
- Light output 5810 lux at 3 m
- Beamwidth: 9° to 17° with the Frost filter
- Removable Frost filter

### MATERIALS

- Die-cast aluminium housing with a black gloss finishing
- Safety glass
- Tightness level : 65 (fully protected against dust and water projections)

### FUNCTIONS

- Built-in command system with a drop-down menu to select the different modes :
- Manual, Automatic, DMX (4, 6, 8 or 11/ channels).
- 8 Built-in programs accessible via the DMX.
- 10 user programs accessible via the menu.

### TECHNICAL SPECIFICATIONS

- DMX inputs and outputs.
- Power cord with a 4-pin IP connector
- DMX IN/OUT cables with 3-pin IP connectors

- Power supply : DC 22,2 - 26,2V - 70W with an optional external power unit
- Dimensions : (L x W x H) : 370 x 178 x 110 mm
- Weight : 6.8 kg

### OPTIONAL ACCESSORIES:

- External power units : IPFLOOD-POW (10287)
- Charging flight case for 6 IPFLOOD-5x15QC : FLYIPFLOOD-S1 (10264)
- DMX wireless transmitter/Receiver: WDMX-ERIP (10301)

## WDMX-ERIP

DMX wireless and waterproof transmitter/receiver  
ref 10301

The WDLX-ERIP is a wireless DMX receiver/transmitter. It's the easiest way to install your projectors.

- + Weatherproof housing
- + Transmitter/receiver
- + High-quality manufacturing
- + Wireless Solution compatible

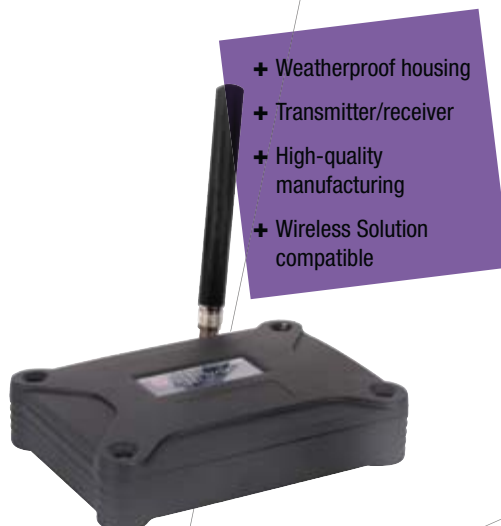

## TECHNICAL SPECIFICATIONS

- DMX channels: 512 DMX channels per unit you can daisy chain up to 16 units
- Frequency band: 2.45 GHz
- Compatibility : W-DMX G4 or G3 protocols
- Compatible : DMX and RDM signals
- Adaptive Frequency Hopping Radio
- Average range : 100 m in open land
- Power supply : 100/240V ~50/60Hz - 3W, AC
- Plastic housing : Black finishing
- Weatherproof : IP65 (fully protected against dust and water projections)
- Dimensions : 240 x 170 x 57 mm
- Net weight : 1.9 kg

# NOUVELLE GAMME IPZOOM

Magnifiez la pierre par tous les temps\*

\*Magnify stone in all weathers





# IPZOOM SERIES

Our waterproof CONTEST architecture series keeps getting bigger, with two new references: IPZOOM3x15QC and IPZOOM7x15QC.

Like the IPSPOT series, they were designed to bring out surfaces and outdoor reliefs, regardless of the current weather.

They feature a 15W RGBW LED, and deliver an exceptional light output. This new source, combined to a powerful ZOOM, generates perfect projection quality and a consistent colour mix.



## THOUGHT-OUT FOR INSTALLATIONS

Our IPZOOM projectors feature the perfect design for permanent and temporary installations. The cast aluminium housing is very resistant, IP65-compliant and allows a continued use outdoors. The pressure valve was created to prevent condensation and liquid suction through the cables.

A very intuitive OLED display allows you to visualize menus and options directly from the projector. Touch-sensitive buttons ensure waterproof protection while being resistant to wear over time.

The double fixation bracket with mechanical lock brings optimal stability to the projectors during ground handling phases. It was designed to hang your projector or use a standard fixation system, but also to smoothly and discreetly let cables run through.

## WATERPROOF CONNECTORS

IPZOOM and IPSPOT projectors all feature inputs and outputs dedicated to power supplying and DMX connections. In order to promote both discretion and simplified cabling, IPZOOM projectors are also equipped with waterproof SEETRONIC® housing and plugs.

Unused chassis remain sealed thanks to sealing plugs. In addition to the supplied adapters, you will also find a whole range of optional cables and accessories in order to create waterproof connections with more of our products.



# IPZOOM 7X15QC

Waterproof projector with 7 x 15W 4-in-1 LEDs and zoom  
ref 10657

122

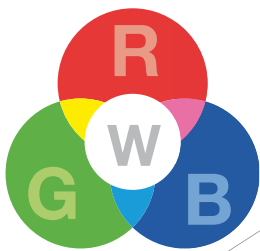

NEW

- + Powerful LEDs
- + Long-range zoom
- + Very strong aluminium housing
- + Resistant to water projections
- + Power and DMX IN/OUT via Seetronic<sup>®</sup> sealed connectors



## TECHNICAL SPECIFICATIONS

### OPTICAL

- 7 x 15W 4-in-1 RGBW LEDs
- Light output from 1250 to 13800 Lux at 3m depending on beamwidth
- Double lenses designed for an optimal light diffusion
- Motorized zoom aperture: 12° - 45°

### FUNCTIONS

- Built-in command panel with touchscreen. OLED drop-down display to:
- Select the DMX address

- Select the number of channels: 3,5,7 or 9
- Select presets and built-in shows
- Select dimming curves
- Master/Slave mode
- Manual mode

### CONNECTIONS

- DMX IN and OUT via 3-pin XLR SEETRONIC<sup>®</sup> socket with waterproof plug
- POWER IN/OUT via 3-pole SEETRONIC<sup>®</sup> socket with waterproof plug

- Power supply: 100-240V/50-60Hz
- Power consumption: 130W
- IP level: IP65
- Convection-cooled, so it is completely silent
- Pressure valve with waterproof membrane
- Finish: black cast aluminium
- Dimensions: 270 x 320 x 320 mm
- Weight: 9,9 kg



# IPZOOM3X15QC

Waterproof projector with 3 x 15W 4-in-1 LEDs and zoom  
ref 10656

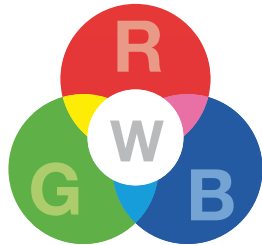

NEW



- + Powerful LEDs
- + Long-range zoom
- + Very strong aluminium housing
- + Resistant to water projections
- + Power and DMX IN/OUT via Seetronic<sup>®</sup> sealed connectors

123



## TECHNICAL SPECIFICATIONS

### OPTICAL

- 3 15W 4-in-1 RGBW LEDs
- Light output from 625 - 7760 Lux at 3m depending on beamwidth
- Double lenses designed for an optimal light diffusion
- Motorized zoom aperture: 12° - 45°

### FUNCTIONS

- Built-in command panel with touchscreen. OLED drop-down display to:
- Select the DMX address

- Select the number of channels: 3,5,7 or 9
- Select presets and built-in shows
- Select dimming curves
- Master/Slave mode
- Manual mode

### CONNECTIONS

- DMX IN and OUT via 3-pin XLR SEETRONIC<sup>®</sup> socket with waterproof plug
- POWER IN/OUT via 3-pole SEETRONIC<sup>®</sup> socket with waterproof plug

- Power supply: 100-240V/50-60Hz
- Power consumption: 70 W
- IP level: IP65
- Convection-cooled, so it is completely silent
- Pressure valve with waterproof membrane
- Finish: black cast aluminium
- Dimensions: 245 x 250 x 270 mm
- Weight: 5,8 kg



## IPZOOM ACCESSORIES

|       |  |
|-------|--|
| 10716 | SC3FXX-W - Seetronic Waterproof XLR 3P female connector - IP65 |
| 10717 | SC3MXX-W - Seetronic Waterproof XLR 3P male connector - IP65   |
| 10718 | SC5FXX-W - Seetronic Waterproof XLR 5P female connector - IP65 |
| 10719 | SC5MXX-W - Seetronic Waterproof XLR 5P female connector - IP65 |
| 10720 | SAC3FX - Seetronic Waterproof Power in connector - IP65        |
| 10721 | SAC3MX - Seetronic Waterproof Power out connector - IP65       |

|       |  |
|-------|--|
| 10722 | IPCD-1 - 3P Waterproof DMX connection cable - 1m |
| 10723 | IPCD-2 - 3P Waterproof DMX connection cable - 2m |
| 10724 | IPCD-5 - 3P Waterproof DMX connection cable - 5m |
| 10725 | IPCP-1 - Waterproof male power connector - 1m    |
| 10726 | IPCP-2 - Waterproof male power connector - 2m    |
| 10727 | IPCP-5 - Waterproof male power connector - 5m    |

# IPSPOT12SIX

12x12W 6-colour LEDs weatherproof projector  
ref 10266

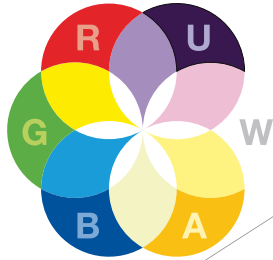

- + 12x12W 6-colour (RVBWA and UV) LEDs
- + Supplied with an infrared remote control
- + Customisable built-in programs
- + Very resistant, protected against water projections
- + New Master Dimmer mode

## TECHNICAL SPECIFICATIONS

### OPTICAL

- 12x12W 6-colour LEDs - 30,000 hours
- Light output: 1345 Lux at 3m
- Clear Crystal lenses for a perfect beam diffusion
- Lenses aperture angle : 40°

### ITS STRENGTHS :

- 6-colour LEDs
- Add UV light to create unrivaled colours
- Manual, DMX and Auto modes, customisables
- Supplied with a multifunction remote control
- Infrared sensor (front)
- IN/OUT power supply sockets

### FUNCTIONS :

- Built-in command panel with a drop-down menu allowing the:
  - DMX addressing
  - DMX channels : 3 to 10
  - Built-in programs selection
  - Built-in colours selection
  - Mode Master/Slave
- Creation of a 20-step fully customisable user program
- Use of the infrared remote control to remotely access the main functions

### CONNECTORS :

- 3-pin DMXIN/OUT connectors
- 3-pin POWER IN/OUT connectors

- Power supply : 100-240V/50-60Hz

- Power consumption : 155W

- Tightness level : IP65

- Finishing : Black

- Dimensions : 285 x 210 x 315 mm

- Weight : 6.5 kg

### PACKAGE CONTENTS :

- The projector
- The user guide
- A double hanging bracket
- An infrared remote control
- An IP/IEC 2-pole + earth power cord
- 2 IP/DMX cables (IN and OUT)
- 3 end caps : DMX IN and OUT + Power supply

## FLY-irLED-64x6

Flight case for 6 IPSPOT12SIX projectors  
ref 10338

This flight case has been specifically designed to safely transport your irLED64 projectors and all their accessories.



# IPSPOT5SIX

5x12W 6-colour LEDs weatherproof projector  
ref 10265

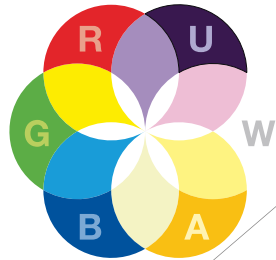

- + 5x12W 6-colour (RVBWA and UV) LEDs
- + Supplied with an infrared remote control
- + Customisable built-in programs
- + Very resistant, protected against water projections
- + New Master Dimmer mode



## TECHNICAL SPECIFICATIONS

### OPTICAL

- 5x12W 6-colour LEDs - 30,000 hours
- Light output: 623 Lux at 3m
- Clear Crystal lenses for a perfect beam diffusion
- Lenses aperture angle : 40°

### ITS STRENGTHS :

- 6-colour LEDs
- Add UV light to create unrivaled colours
- Manual, DMX and Auto modes, customisables
- Supplied with a multifunction remote control
- Infrared sensor (front)
- IN/OUT power supply sockets

### FUNCTIONS :

- Built-in command panel with a drop-down menu allowing the:
- DMX addressing
- DMX channels : 3 to 40
- Built-in programs selection
- Built-in colours selection
- Mode Master/Slave
- Creation of a 20-step fully customisable user program
- Use of the infrared remote control to remotely access the main functions

### CONNECTORS :

- 3-pin DMXIN/OUT connectors
- 3-pin POWER IN/OUT connectors

- Power supply : 100-240V/50-60Hz
- Power consumption : 65 W
- Tightness level : IP65
- Finishing : Black
- Dimensions : 250 x 190 x 300 mm
- Weight : 5.5 kg

### PACKAGE CONTENTS :

- The projector
- The user guide
- A double hanging bracket
- An infrared remote control
- An IP/IEC 2-pole + earth power cord
- 2 IP/DMX cables (IN and OUT)
- 3 end caps : DMX IN and OUT + Power supply

## ACCESSORIES



| Model       |  | Ref  |
|-------------|--|------|
| AIP-FicDMXf | Waterproof DMX female connector - IP68         | 9940 |
| AIP-FicDMXm | Waterproof DMX male connector - IP68           | 9941 |
| AIP-FicPOWf | Waterproof female power connector - IP68       | 9942 |
| AIP-FicPOWm | Waterproof male power connector - IP68         | 9943 |
| AIP-BouDMXf | Waterproof female DMX end cap - IP68           | 9944 |
| AIP-BouDMXm | Waterproof male DMX end cap - IP68             | 9945 |
| AIP-BouPOWf | Waterproof female power cap - IP68             | 9946 |
| AIP-CorPOW2 | Waterproof electric connection link IP68 - 2 m | 9948 |
| AIP-CorPOW5 | Waterproof electric connection link IP68 - 5 m | 9949 |

|                 |   |        |
|-----------------|---|--------|
| AIP-CorDMX2     | Waterproof DMX connection cable IP68 - 2 m      | 9950   |
| AIP-CorDMX5     | Waterproof DMX connection cable IP68 - 5 m      | 9951   |
| AIP-ADAPTDMXOUT | Male DMX IP68-XLR IP adaptor - female XLR - 1 m | Z07378 |
| AIP-ADAPTDMXIN  | Female DMX IP68-XLR IP adaptor - male XLR- 1 m  | Z07379 |
| AIP-ADAPTPOWout | Female IP68 -VDE power adaptor - male-1 m       | Z07380 |



# IPSPOT 15QC

ref 9935

This outdoor 15 quadrichromic LEDs projector produces an incredible brightness and a vast colour range. It is perfect for architectural lighting and adapts to all kinds of usage thanks to its many functions.

126



## TECHNICAL SPECIFICATIONS

### • Functions :

- Built-in command panel with drop-down display menu allowing you to :
- Select the DMX addressing
- Choose from 2-7 channels
- Select one of the built-in programs
- Select the built-in colours
- Use the Master/Slave mode
- New Master Dimmer mode
- The infrared remote control gives you a distant access to all the remote functions.

### • Optical :

- 15 5W quadrichromic LEDs - 50 000 hours
- Light output: 2360 Lux at 3m
- Lenses aperture angle : 40°

### • Connectors :

- DMX IN/OUT via 3-pin IP plugs
- POWER IN/OUT via 3-pin IP plugs
- Power supply : 100-240 V/50-60 Hz
- Power consumption : 95 W
- Tightness level : IP65
- Colour : Black
- Measurements : 285 x 210 x 315 mm
- Net weight : 6.2 kg

## FLY-irLED-64x6

Flight case for 6 IPSPOT

ref 10338

This flight case has been specifically designed to safely transport your irLED64 projectors and all their accessories.



# IPSPOT 7QC

ref 9934

Bright and compact, the IPSPOT7QC is a very affordable, cost-efficient and multipurpose outdoor projector very good at architectural lighting. The 7.5 Watts quadrichromic LEDs, the numerous functions and very large aperture angle are has many reasons to consider it a very good product.



## TECHNICAL SPECIFICATIONS

### • Functions :

- Built-in command panel with drop-down display menu allowing you to :
  - Select the DMX addressing
  - Choose from 2-7 channels
  - Select one of the built-in programs
  - Select the built-in colours
  - Use the Master/Slave mode
  - New Master Dimmer mode
- The infrared remote control gives you a distant access to all the remote functions.

### • Optical :

- 7.5 W quadrichromic LEDs - 50 000 hours
- Light output: 1007 Lux at 3 m
- Lenses aperture angle : 40°

### • Connectors :

- DMX IN et OUT par fiches IP 3 broches
- POWER IN/OUT par fiches IP 3 broches

### • Power supply : 100-240 V/50-60 Hz

### • Power consumption : 50 W

### • Tightness level : IP65

### • Colour : Black

### • Measurements : 250 x 190 x 300 mm

### • Weight : 5.2 kg



# IPLINE SERIES

The IPLINE series features low-angled indoor and outdoor projectors. Their incredibly powerful colorization allow them to illuminate 7 meter high walls. They are absolutely perfect if you want to bring a sign forward, or rejuvenate a building. The supplied remote control gives a total control over these projectors and a full access to the built-in programs and various functions.



Duo pixel control



128

## IPLINE12SIX

ref 10267

• Optical

- 12x12W 6-colour LEDs - 30 000 hours
- Light output: 1212 Lux at 3m
- Clear Crystal lenses for a perfect beam diffusion
- Lenses aperture angle : 40°

• Materials

Aluminium housing with black finishing

Safety glass

• IP tightening level:

- IP44 (protected from dust and oriented water sprays)

## IPLINE18TC

ref 9838

• Optical :

- 18 3W tricolor LEDs (RGB) - 50 000 hours
- Lenses aperture angle : 30°
- Light output : 690 Lux at 3 m

• Materials :

- Aluminium housing
- Safety glass

• IP Tightening level :

- IP44 (Protected from dust and oriented water sprays)



All accessories  
page 111

## IPLINE12AW

ref 9918

• Optical :

- 12 5 W bicolore LEDs White/Amber - 30 000 hours
- Lenses aperture angle : 40°
- Light output : 660 Lux at 3 m

• Materials :

- Aluminium housing
- Safety glass

• IP tightening level :

- IP44 (Protected from dust and oriented water sprays)



### ACCESSORIES FOR IPLINE18TC AND IPLINE12AW

#### DMX1

DMX IP to XLR 3-pin adaptor - 1 metre

ref 9109

#### DMX2

Waterproof DMX connection cable – 2 metres

ref 9110

#### DMX5

Waterproof DMX connection cable – 5 metres

ref 9111





**10 DIFFERENT MODES :**

- 3 DMX channels : Macro / Dimmer / Fixed colours / Pattern / Speed
- 6 DMX channels : RGBWAUV
- 7 DMX channels : RGBWAUV / Master dimmer / Strobe
- 8 DMX channels : RGBWAUV / Master dimmer / Strobe
- 10 DMX channels : RGBWA+UV / Fixed colours / Macros / Patterns / Dimmer / Strobe / Speed

- 40 DMX channels: Zone control / Fixed colours / Macros / Patterns / Dimmer / Strobe / Speed
- Built-in sequencing programs selection
- Built-in macro selection
- Built-in colour selection
- Master/Slave mode

**TECHNICAL SPECIFICATIONS**

- 3-pin IP68 DMX IN/OUT socket
- 3-pin IP68 IN/OUT power socket
- Power consumption: 150W
- Power supply: 100-240V/50-60 Hz
- Dimensions: 1000x 184 x 77 mm
- Weight: 5.5 kg

**ACCESSORIES FOR IPLINE12SIX**

| Model       |  | Ref  |
|-------------|--|------|
| AIP-FicDMXf | Waterproof DMX female connector - IP68   | 9940 |
| AIP-FicDMXm | Waterproof DMX male connector - IP68     | 9941 |
| AIP-FicPOWf | Waterproof female power connector - IP68 | 9942 |
| AIP-FicPOWm | Waterproof male power connector - IP68   | 9943 |
| AIP-BouDMXf | Waterproof female DMX end cap - IP68     | 9944 |
| AIP-BouDMXm | Waterproof male DMX end cap - IP68       | 9945 |
| AIP-BouPOWf | Waterproof male power cap - IP68         | 9946 |

|                  |  |        |
|------------------|--|--------|
| AIP-CorPOW2      | Waterproof electric connection link IP68 - 2 m | 9948   |
| AIP-CorPOW5      | Waterproof electric connection link IP68 - 5 m | 9949   |
| AIP-CorDMX2      | Waterproof DMX connection cable IP68 - 2 m     | 9950   |
| AIP-CorDMX5      | Waterproof DMX connection cable IP68 - 5 m     | 9951   |
| AIP-ADAPTD-MXOUT | Male DMX IP68-XLR IP adaptor - female XLR -1 m | Z07378 |
| AIP-ADAPTD-MXIN  | Female DMX IP68-XLR IP adaptor - male XLR-1 m  | Z07379 |
| AIP-ADAPT-POWout | Female IP68 -VDE power adaptor - male-1 m      | Z07380 |



**10 DIFFERENT MODES :**

- 2 DMX channels : Macro, Dimmer
- 3 DMX channels : Red, Green, Blue
- 4 DMX channels : Red, Green, Blue, Dimmer/Strobe
- 5 DMX channels : Red, Green, Blue, Dimmer, Strobe
- 6 DMX channels : Red, Green, Blue, Dimmer, Strobe, Macro
- Fade/Step programs with adjustable speed
- Fixed preset colours
- Manual mode
- Automatic mode
- Slave mode

**TECHNICAL SPECIFICATIONS**

- Power consumption : 65 W
- Power supply : 100/240 V - 50/60 Hz, AC
- IP Input/output power sockets
- IP DMX input/output
- IP-DMX and IP power supply adapters (supplied)
- Infrared remote control
- Double holding bracket
- Measurements : 100 x 80 x 170 mm
- Weight : 5.3 kg



**8 DIFFERENT MODES :**

- 2 DMX channels : White, Amber
- 4 DMX channels : White, Amber, Dimmer
- 6 DMX channels : White, Amber, Dimmer, Strobe, Colour macros/ Fixed colours (Varying from white to amber), Control macro
- Preset White colour variations
- Manual mode
- Fade/Step programs with adjustable speed
- Automatic mode
- Slave mode

**TECHNICAL SPECIFICATIONS**

- Power consumption : 65 W
- Power supply : 100/240 V - 50/60 Hz, AC
- Power Input/output
- IP DMX input/output
- IP-DMX and IP power supply adapters (supplied)
- Infrared remote control
- Double holding bracket
- Measurements : 100 x 80 x 170 mm
- Weight : 5 kg



**C-POWER2**

Waterproof electric connection link – 2 metres  
ref 9112

**C-POWER5**

Waterproof electric connection link – 5 metres  
ref 9113

**IPT1**

1 female to 2 males electrical  
Tee connector  
ref 9128

**IPT2**

1 Male / 2 Females Tee water-  
proof connector  
ref 9129

# NOUVEAU Artist10W

La projection gobo sur-mesure\*

\*Tailor-made gobo projection



by **Contest**<sup>®</sup>





# Artist10W

Gobo projector

**Gobo projector with 10W LED**

ref 10651

NEW

- + Supplied with a selection of gobos
- + Gobos can be personalized
- + Direct access to rotation speed control
- + Timer mode to stop the device after 6 hours of use



131



Supplied with a selection of gobos. Gobos can be printed on transparency films, polyester film of high resistance for Laser or Inkjet printers

Gobo format: external diameter of 35mm, maximum image diameter of 26mm

## TECHNICAL SPECIFICATIONS

- 1 X 10W WHITE LED
- Rotation speed control
- Power button, standby and Timer auto off
- Power consumption: 12W maximum
- Power supply: 100/240V, AC - 50/60Hz via the 12V DC supplied adapter
- PLASTIC HOUSING RESISTANT TO WATER SPLASHES
- Suspension bracket, table support and nail for ground fixation
- Dimensions: 170 x 140 x 240 mm
- Weight: 0.700 kg





# GLOSSARY

## Where should I use FLEX-LED?

FLEX-LED can be used indoor, to brighten or enhance a room, but also outdoor, for building and objects illumination thanks to this series including IP20, IP65 & IP67 products.

## What kind of LED?

Our catalogue offers 6 kinds of LED:

### Perfect for functional lighting



5054 : 4 chips (RGBW) from 0.32w/led  
Strong light output



5630 : 1 chip from 0.33w/led  
Very high light output  
Monochromatic only



5050 : 3 chips (RGB) from 0.24w/led  
Strong light output



5050 : 1 chip warm white or cold white from 0.24w/led  
High light output

### Perfect for ambient lighting



3527 : 2 chips (warm white cold white) from 0.16w/led



WS2812B :  
3 RGB chips of 0.24w/LED with built-in command circuit  
Each LED can be controlled independently

## WHY CHOOSE LEDS ?

- Very long lifespan, low maintenance
- Low energy cost
- Resistant to shocks and vibrations
- Very compact format
- No infrared or UV emissions

## Maximum ribbon length

The maximum ribbon length is not only determined by the power supply unit and driver, but also by the maximum current supported by the circuit which constitutes the ribbon.

Powering up the ribbon by both its extremities will allow you to double the maximum ribbon length indicated in the chart below.

|       |                        | Max length |
|-------|------------------------|------------|
| 9859  | COLORTAPE3065          | 16 m       |
| 10541 | COLORTAPE6020          | 8 m        |
| 10542 | COLORTAPE6020-WARM     | 5 m        |
| 9994  | COLORTAPE6065          | 8 m        |
| 9860  | COLORTAPE6067          | 8 m        |
| 10543 | COLORTAPE6067-WARM     | 5 m        |
| 10539 | PURETAPE12020-WARMCOLD | 5 m        |
| 10540 | PURETAPE12067-WARMCOLD | 5 m        |
| 10538 | PURETAPE14420-COLD     | 5 m        |
| 10536 | PURETAPE14420-WARM     | 5 m        |
| 10537 | PURETAPE6020-COLD      | 8 m        |
| 10535 | PURETAPE6020-WARM      | 8 m        |
| 9862  | PURETAPE6067-COLD      | 8 m        |
| 9861  | PURETAPE6067-WARM      | 8 m        |

## Ribbons and power consumption

How much power does a W ribbon requires and which power supply should I use ?

### Example:

9m of RGB 60 LEDs/m 14.4 W/m ribbon at 24 V (COLORTAPE6065)

Power consumption of a ribbon (en W) = length (m) x powers/metre (w/m)

The ribbon will consume  $14.4 \times 9 = 129.6$  W

### CHOOSING A POWER SUPPLY UNIT:

It is necessary to choose a power supply generating at least 10% extra power than required.

Using the same example :  $129.6 + 10\% = 142.56$  W

**POW246IP2 which produces 150 W**



## Tightness level



### 1ST DIGIT: SOLID PARTICLE PROTECTION

- IP 0X no protection
- IP 1X protected against solid particles larger than 50mm (ex.: hand contact)
- IP 2X protected against solid particles larger than 12mm (ex.: finger)
- IP 6X fully protected against dust

### 2EME DIGIT: LIQUID PROTECTION

- IP X0 no protection
- IP X5 protected from water projections from a nozzle in all directions
- IP X7 protected against immersion effects
- IP X8 suitable for immersion under specific circumstances

## Ra, also known as IRC

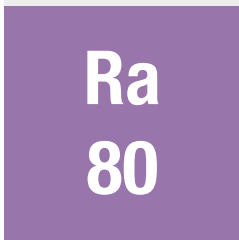

Ra levels equal to 100 match natural daylight. Colours are then perceived without any change (or loss) by the human eye.

When LEDs produce artificial light, they cannot reach CRI levels higher than 90. When installations require to be faithful to true colours (e.g. outlets, or exposition centres), it is crucial to choose equipments with IRC levels higher than 70.

## Light diffusers

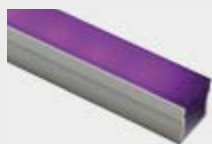

### Milk - Opal glass diffuser

Diffusion, for marking purposes. You cannot see LEDs

### Frost - 50% diffuser

Ambient lighting.  
(if the profile is deep enough).

### Crystal - Transparent

For lighting, allows to protect LEDs.

Using a sleeve might impact the light output of your ribbons, depending on its opacity.

## Flicker Free

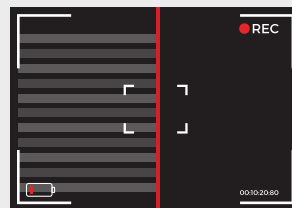

**Flicker-free** means we eradicated any flickering from light sources which usually ruin video displays.

All our ribbons, power supply units and drivers are designed to prevent this.

## Colour Temperature

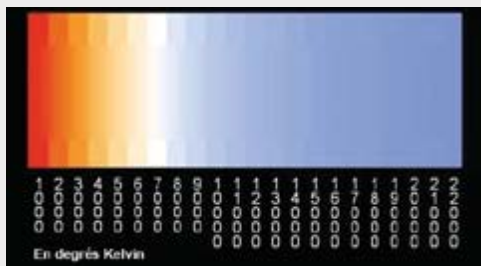

Colour temperature is expressed in Kelvin degrees (K°)  
The lower the degree, the warmer the light, whereas higher degrees offer colder shades.

## Binning

"Binning" is a selection process allowing to guarantee uniformity among LED batches.  
Thus, batches are usually designed to have the same characteristics.

However, it is good to know that there might be some significant differences between LED batches.



Our PURETAPE-WARM has been designed to create cozy, intimate ambient lighting with a surprising brightness perfectly adapted for outdoor and indoor lighting, with two models including one with high power and one IP67 product for outdoor wonders.

134



ANGLE ACCESSORIES

Finalise your installation thanks to our "L", "T", and "X" accessories series.

WARM WHITE VERSION WITH 60 LEDS PER METRE AND SILICONE SLEEVE IP67

|      |           |              |       |
|------|-----------|--------------|-------|
| IP67 | 60 LEDs/m | LED SMD 5050 | Ra 80 |
|------|-----------|--------------|-------|

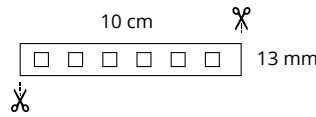

PURETAPE6067-WARM - Ref 9861

|                       |                |
|-----------------------|----------------|
| Colour temperature    | 3000 K         |
| Voltage               | 24 V           |
| Power/m               | 14,4 W         |
| Light output          | 732 lm/m       |
| Length of each ribbon | 5 m            |
| Sectile parts         | 10 cm (6 LEDs) |



- + 3000°K Warm White
- + SMD5050 high-rendering LED
- + With silicone sleeve
- + IP67 Version
- + 3M Adhesive tape and eye straps

WARM WHITE VERSION WITH 60 LEDS PER METRE IP20

|      |           |              |       |
|------|-----------|--------------|-------|
| IP20 | 60 LEDs/m | LED SMD 5050 | Ra 80 |
|------|-----------|--------------|-------|

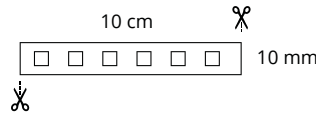

PURETAPE6020-WARM - Ref 10535

|                       |                |
|-----------------------|----------------|
| Colour temperature    | 3000 K         |
| Voltage               | 24 V           |
| Power/m               | 14,4 W         |
| Light output          | 915 lm/m       |
| Length of each ribbon | 5 m            |
| Sectile parts         | 10 cm (6 LEDs) |



- + 3000°K Warm White
- + SMD5050 high-rendering LED
- + 3M Adhesive tape

HIGH POWER WARM WHITE VERSION WITH 144 LEDS PER METRE IP20

|      |            |              |       |
|------|------------|--------------|-------|
| IP20 | 144 LEDs/m | LED SMD 5630 | Ra 80 |
|------|------------|--------------|-------|

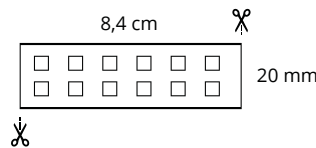

PURETAPE14420-WARM - Ref 10536

|                       |                  |
|-----------------------|------------------|
| Colour temperature    | 3000 K           |
| Voltage               | 24 V             |
| Power/m               | 47,5 W           |
| Light output          | 2452 lm/m        |
| Length of each ribbon | 5 m              |
| Sectile parts         | 8,4 cm (12 LEDs) |



- + High power-per-meter ratio
- + 3000°K Warm White
- + SMD5630 high-rendering LED
- + 3M Adhesive tape

CAUTION

A heat sink is required due to the high power of the ribbon. See our aluminium profiles





POSSIBLE SETUP

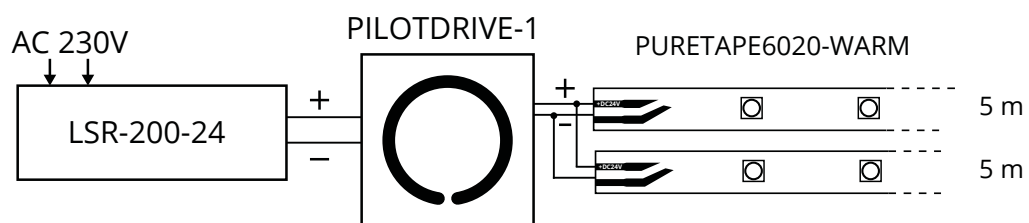



POSSIBLE SETUP

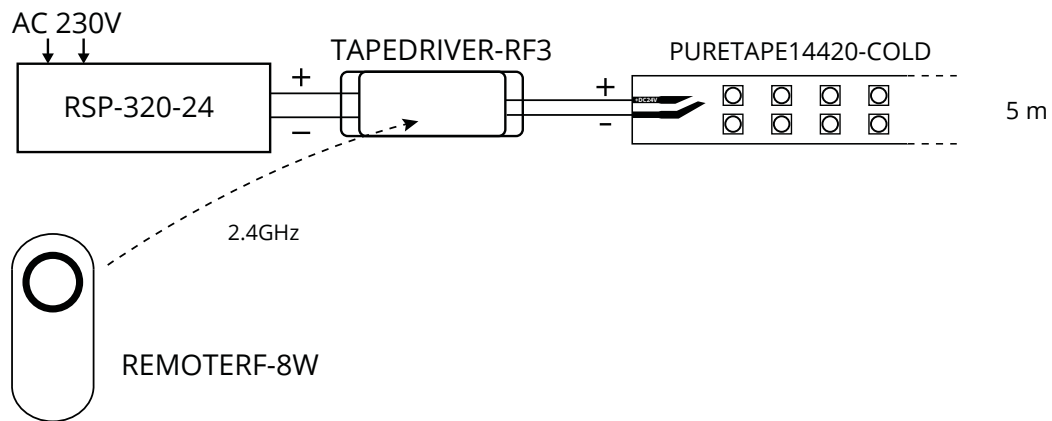

**COLD WHITE VERSION WITH 60 LEDS PER METRE AND SILICONE SLEEVE IP67**

|      |              |                    |          |
|------|--------------|--------------------|----------|
| IP67 | 60<br>LEDs/m | LED<br>SMD<br>5050 | Ra<br>85 |
|------|--------------|--------------------|----------|

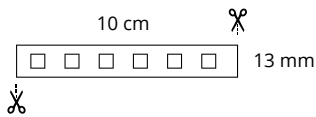

PURETAPE6067-COLD - Ref 9862

|                       |                |
|-----------------------|----------------|
| Colour temperature    | 6000 K         |
| Voltage               | 24 V           |
| Power/m               | 14,4 W         |
| Light output          | 952 lm/m       |
| Length of each ribbon | 5 m            |
| Sectile parts         | 10 cm (6 LEDs) |

- + 6000°K Cold White
- + SMD5050 high-rendering LED
- + With silicone sleeve
- + IP67 Version
- + 3M Adhesive tape and eye straps

**COLD WHITE VERSION WITH 60 LEDS PER METRE IP20**

|      |              |                    |          |
|------|--------------|--------------------|----------|
| IP20 | 60<br>LEDs/m | LED<br>SMD<br>5050 | Ra<br>85 |
|------|--------------|--------------------|----------|

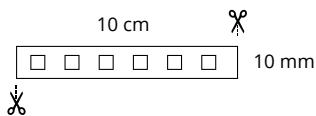

PURETAPE6020-COLD - Ref 10537

|                       |                |
|-----------------------|----------------|
| Colour temperature    | 6000 K         |
| Voltage               | 24 V           |
| Power/m               | 14,4 W         |
| Light output          | 1190 lm/m      |
| Length of each ribbon | 5 m            |
| Sectile parts         | 10 cm (6 LEDs) |

- + 6000°K Cold White
- + SMD5050 high-rendering LED
- + 3M Adhesive tape

**HIGH POWER COLD WHITE VERSION WITH 144 LEDS PER METRE IP20**

|      |               |                    |          |
|------|---------------|--------------------|----------|
| IP20 | 144<br>LEDs/m | LED<br>SMD<br>5630 | Ra<br>85 |
|------|---------------|--------------------|----------|

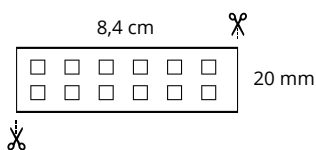

PURETAPE14420-COLD - Ref 10538

|                       |                  |
|-----------------------|------------------|
| Colour temperature    | 6000 K           |
| Voltage               | 24 V             |
| Power/m               | 47,5 W           |
| Light output          | 3065 lm/m        |
| Length of each ribbon | 5 m              |
| Sectile parts         | 8,4 cm (12 LEDs) |

- + High power-per-meter ratio
- + 6000°K Cold White
- + SMD5630 high-rendering LED
- + 3M Adhesive tape

**CAUTION**

A heat sink is required due to the high power of the ribbon.

See our aluminium profiles

The PURETAPE ribbons offer vivid white illumination perfectly adapted to ambient lighting or to rejuvenate buildings, furnitures and spaces, with two models including one with high power and one IP67 product for outdoor wonders.



The PILOTdrive1 wall-mount driver is a tactile power interface. It allows you to adjust the colour temperature and power up your LED ribbons installation.



WARM WHITE / COLD WHITE FLEX LED



WARM WHITE / COLD WHITE VERSION WITH 120 LEDS PER METRE WITH SILICONE SLEEVE IP67

**IP67**    **120** LEDs/m    **LED SMD 3527**    **Ra 80-85**

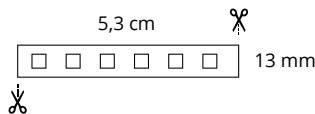

PURETAPE12067-WARMCOLD - Ref 10540

|                       |                 |
|-----------------------|-----------------|
| Colour temperature    | 3500 K/6500 K   |
| Voltage               | 24 V            |
| Power/m               | 19,2 W          |
| Light output          | 1264 lm/m       |
| Length of each ribbon | 5 m             |
| Section parts         | 5,3 cm (6 LEDs) |



- + 3500/6000°K Warm/Cold White
- + SMD3527 high-rendering LED
- + With silicone sleeve
- + IP67 Version
- + 3M Adhesive tape

138

The PURETAPE-WARMCOLD series was designed to bring you white colours at precise temperature, and delivers an incredible brightness, perfectly adapted to situations that require a lot of precision when it comes to white colours, should it be indoor or outdoor, thanks to the IP67 model.

WARM WHITE / COLD WHITE VERSION WITH 120 LEDS PER METRE IP20

**IP20**    **120** LEDs/m    **LED SMD 3527**    **Ra 80-85**

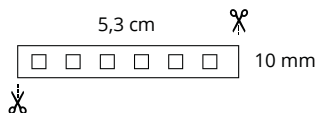

PURETAPE12020-WARMCOLD - Ref 10539

|                       |                 |
|-----------------------|-----------------|
| Colour temperature    | 3500 K/6500 K   |
| Voltage               | 24 V            |
| Power/m               | 19,2 W          |
| Light output          | 1264 lm/m       |
| Length of each ribbon | 5 m             |
| Section parts         | 5,3 cm (6 LEDs) |



- + 3500/6000°K Warm/Cold White
- + SMD3527 high-rendering LED
- + 3M Adhesive tape

**CAUTION**

A heat sink is required due to the high power of the ribbon. See our aluminium profiles

The PILOTdrive2 wall-mount driver is a tactile power interface. It allows you to adjust the colour temperature and power up your LED ribbons installation.





POSSIBLE SETUP

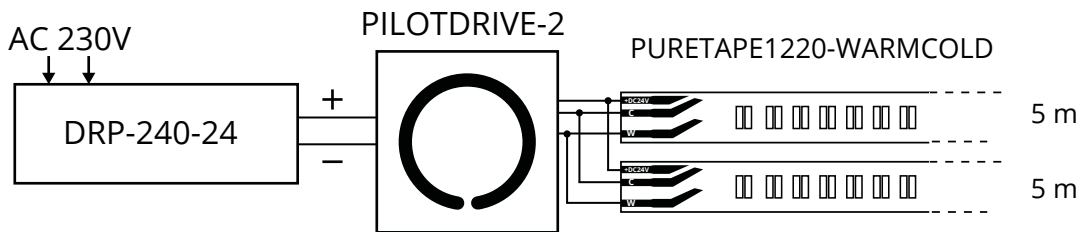



POSSIBLE SETUP

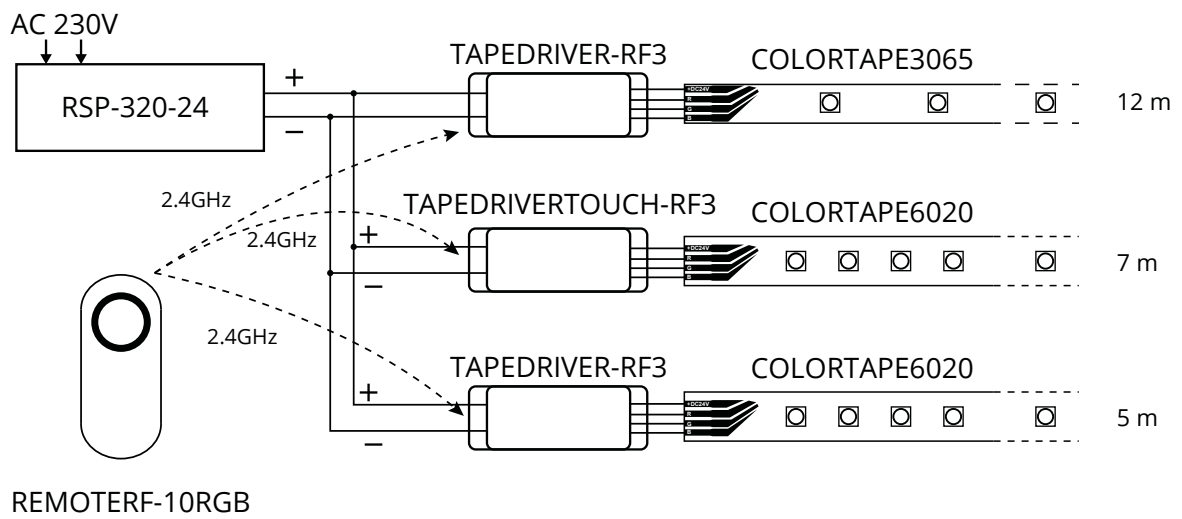





**RGB VERSION WITH 60 LEDS PER METER AND SILICONE SLEEVE IP67**

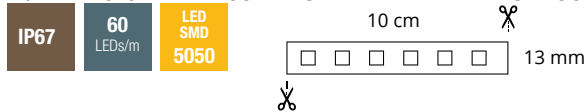

COLORTAPE6067 - Ref 9860

|                       |                |
|-----------------------|----------------|
| Voltage               | 24 V           |
| Power/m               | 14,4 W         |
| Max light output      | 448 lm/m       |
| Length of each ribbon | 5 m            |
| Sectile parts         | 10 cm (6 LEDs) |



- 
- + RGB Version
- + SMD5050 high rendering LED
- + With silicone sleeve
- + IP67 Version
- + 3M Adhesive tape

**RGB VERSION WITH 60 LEDS PER METRE WITH SILICONE DOME IP65**

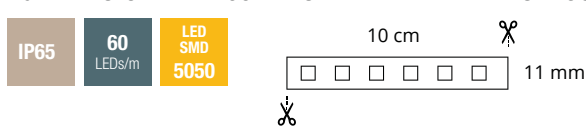

COLORTAPE6065 - Ref 9994

|                       |                |
|-----------------------|----------------|
| Voltage               | 24 V           |
| Power/m               | 14,4 W         |
| Max light output      | 448 lm/m       |
| Length of each ribbon | 5 m            |
| Sectile parts         | 10 cm (6 LEDs) |



- 
- + RGB Version
- + SMD5050 high rendering LED
- + IP65 Version
- + 3M Adhesive tape

**RGB VERSION WITH 30 LEDS PER METRE WITH SILICONE DOME IP65**

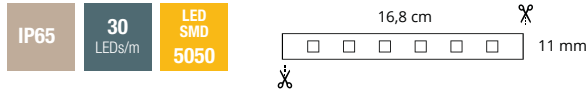

COLORTAPE3065 - Ref 9859

|                       |                  |
|-----------------------|------------------|
| Voltage               | 24 V             |
| Power/m               | 7,2 W            |
| Max light output      | 280 lm/m         |
| Length of each ribbon | 5 m              |
| Sectile parts         | 16,8 cm (6 LEDs) |



- 
- + RGB Version
- + SMD5050 high rendering LED
- + IP65 Version
- + 3M Adhesive tape

**RGB VERSION WITH 60 LEDS PER METRE IP20**

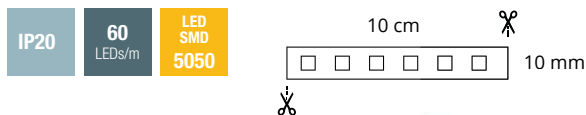

COLORTAPE6020 - Ref 10541

|                       |                |
|-----------------------|----------------|
| Voltage               | 24 V           |
| Power/m               | 14,4 W         |
| Max light output      | 560 lm/m       |
| Length of each ribbon | 5 m            |
| Sectile parts         | 10 cm (6 LEDs) |



- 
- + RGB Version
- + SMD5050 high rendering LED
- + 3M Adhesive tape

The COLORTAPE ribbon can be used indoor or outdoor to create new atmospheres, personalized decorations or emphasize on volumes.

Because it is both compact and flexible, it is also easy to install, without compromising on quality.



**ANGLE ACCESSORIES**

Finalise your installation thanks to our "L", "T", and "X" accessories series.



RGBW VERSION WITH 60 LEDS PER METRE AND SILICONE SLEEVE IP67

**IP67**    **60** LEDs/m    **LED SMD 5054**    **Ra 80-85**

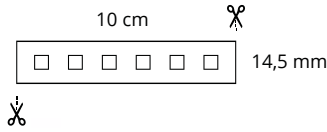

COLORTAPE6067-WARM - Ref 10543

|                       |                |
|-----------------------|----------------|
| Voltage               | 24 V           |
| Power/m               | 19,2 W         |
| Max light output      | 646 lm/m       |
| Length of each ribbon | 5 m            |
| Section parts         | 10 cm (6 LEDs) |



- + RGBW Version
- + SMD5054 high rendering LED
- + With silicone sleeve
- + IP67 Version
- + 3M Adhesive tape and eye straps

142



The PILOTdrive4 wall-mount driver is a tactile power interface. It allows you to adjust the colour temperature and power up your LED ribbons installation.

Useful for gradation, colour temperature control, and RGBW control.

RGBW VERSION WITH 60 LEDS PER METRE IP20

**IP20**    **60** LEDs/m    **LED SMD 5054**    **Ra 80-85**

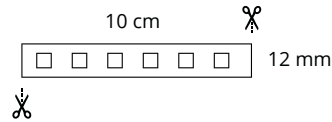

COLORTAPE6020-WARM - Ref 10542

|                       |                |
|-----------------------|----------------|
| Voltage               | 24 V           |
| Power/m               | 19,2 W         |
| Max light output      | 879 lm/m       |
| Length of each ribbon | 5 m            |
| Section parts         | 10 cm (6 LEDs) |



- + RGBW Version
- + SMD5054 high rendering LED
- + 3M Adhesive tape



POSSIBLE SETUP

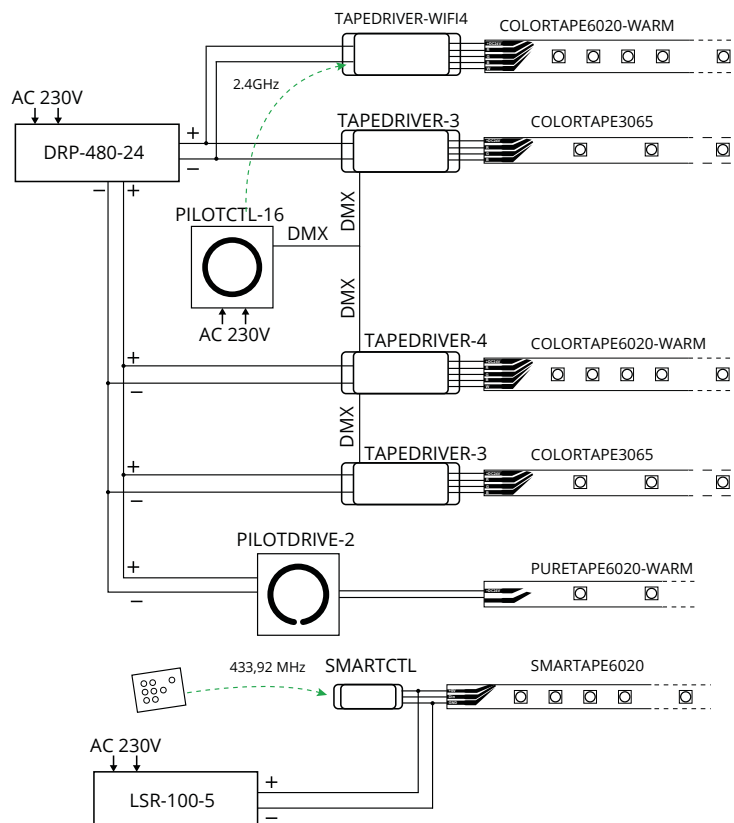



**RGB PIXEL VERSION WITH 30 LEDS PER METRE IP20**

SMARTTAPE ribbons with the latest LED technology: WS2812B. Their SMD5050 (5x5mm) format allows the integrated driver circuit is directly imbedded within the component. These LEDs are more discreet, and fit in 10mm wide ribbons with a pitch of only 16mm for the SMARTTAPE6020.

Installation is easy, as only 3 cables are required to be ready to go (“+”, “-”, Data in).

Combine it with a power supply unit and SMARTCTL driver to unlock 300 patterns and be able to adjust their speed and brightness.

IP20    30 LEDs/m    LED WS2812B    PIXEL

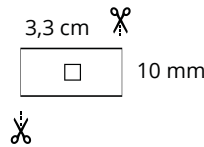

SMARTTAPE3020 - Ref 10596

|                       |                |
|-----------------------|----------------|
| Voltage               | 5 V DC         |
| Power/m               | 7,2 W          |
| Length of each ribbon | 5 m            |
| Sectile parts         | 3,3 cm (1 LED) |



- + RGB Version
- + WS2812B high-rendering LED
- + « PIXEL » Effect
- + 3M Adhesive tape

**RGB PIXEL VERSION WITH 60 LEDS PER METRE IP20**

IP20    60 LEDs/m    LED WS2812B    PIXEL

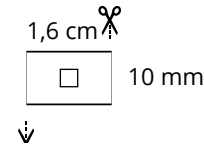

SMARTTAPE6020 - Ref 10597

|                       |                |
|-----------------------|----------------|
| Voltage               | 5 V DC         |
| Power/m               | 14,4 W         |
| Length of each ribbon | 5 m            |
| Sectile parts         | 1,6 cm (1 LED) |



- + RGB Version
- + WS2812B high-rendering LED
- + « PIXEL » Effect
- + 3M Adhesive tape

**DRIVER FOR SMARTTAPE RIBBONS**



SMARTCTL can control up to 20 metres of SMARTTAPE3020 ribbons and up to 6 meters of SMARTTAPE6020 ribbons with 100W power supply unit.

SMARTCTL - Ref 10598

|                                 |            |
|---------------------------------|------------|
| Voltage                         | 5 V DC     |
| Max number of pixels controlled | 2048       |
| Remote control                  | 433,92 MHz |
| Remote control range            | 30 m       |

**SPECIFIC POWER SUPPLY UNITS FOR FLEX SMARTTAPE**



LRS-50-5 - Ref 10599

|                |                  |
|----------------|------------------|
| Voltage        | 5 V DC 50 W max. |
| Output voltage | 5 V DC - 10 A    |
| Nominal power  | 50 W             |
| Supply voltage | 100 - 240 V AC   |



LRS-100-5 - Ref 10600

|                |                   |
|----------------|-------------------|
| Voltage        | 5 V DC 100 W max. |
| Output voltage | 5 V DC - 20 A     |
| Nominal power  | 100 W             |
| Supply voltage | 100 - 240 V AC    |



# LIGHT At your FINGERPRINTS

Discover our new LED light driver series,  
touch-sensitive and wall-mountable.

They are smooth and super-precise, choose the colour and light intensity of your flex LED with the tip of a single finger

## TOUGHENED GLASS designed to LAST

Subtle and elegant, your driver will not fear outdoor uses as it is fiercely protected by high-quality toughened glass.

It is weather-proof, protected against water projections, corrosion, scratches and dust. Moreover, it is easy to clean.



### POSSIBLE SETUPS

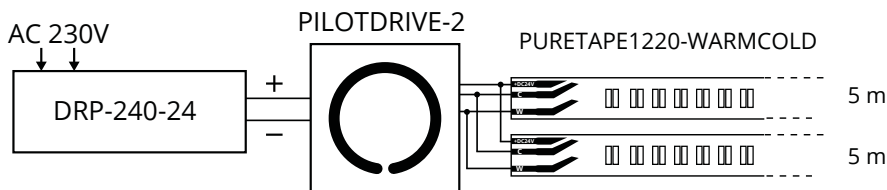



### TOUCH-SENSITIVE POWER DRIVERS

The PILOTdrive series wall-drivers are touch-sensitive power drivers. They power up and control your ribbons installation.

Useful for gradation, colour temperature settings, and RGB and RGBW control.



**288 W**  
**24 V**

PILOTdrive-1 Ref 10560

|                               |  |
|-------------------------------|--|
| Function                      | 5 % to 100 % monochromatic dimmer<br>Direct access to a saved scene<br>« 30S » Ribbon turns off after 30 s |
| Format                        | Wall-mountable   |
| Power supply                  | 12 - 24 V DC   |
| Intensity (Max load, in Amps) | 4 A x 3 (outputs) = 12 A max   |
| Dimensions                    | 86 x 86 x 36 mm  |
| Weight                        | 208 g  |



**192 W**  
**24 V**

PILOTdrive-2 Ref 10561

|                               |   |
|-------------------------------|---|
| Function                      | Warm/cold white dimmer 5 % to 100 %<br>Direct access to a saved scene<br>« Mode » to switch between cold and warm |
| Format                        | Wall-mountable  |
| Power supply                  | 12 - 24 V DC  |
| Intensity (Max load, in Amps) | 4 A x 2 (outputs) = 8 A max   |
| Dimensions                    | 86 x 86 x 36 mm   |
| Weight                        | 208 g   |



**288 W**  
**24 V**

PILOTdrive-3 Ref 10562

|                               |   |
|-------------------------------|---|
| Function                      | RGB Dimmer 5 % à 100 %<br>Direct access to a saved scene<br>11 preset modes |
| Format                        | Wall-mountable  |
| Power supply                  | 12 - 24 V DC  |
| Intensity (Max load, in Amps) | 4 A x 3 (outputs) = 12 A max  |
| Dimensions                    | 86 x 86 x 36 mm   |
| Weight                        | 208 g   |



**384 W**  
**24 V**

PILOTdrive-4 Ref 10563

|                               |  |
|-------------------------------|--|
| Function                      | RGBW Dimmer 5 % à 100 %<br>Direct access to a saved scene<br>11 preset modes- Direct access to white |
| Format                        | Wall-mountable   |
| Power supply                  | 12 - 24 V DC   |
| Intensity (Max load, in Amps) | 4 A x 4 (outputs) = 16 A max   |
| Dimensions                    | 86 x 86 x 36 mm  |
| Weight                        | 208 g  |



**144 W**  
**24 V** **DMX**

PILOT-TOUCH - Ref 9809

|                               |   |
|-------------------------------|---|
| Format                        | Mural   |
| Power supply                  | 12 - 24 V DC  |
| Intensity (Max load, in Amps) | 2A X 3 (outputs) = 6 A max  |
| Function                      | Colour control, dimmer/strobe and programs for RGB ribbons<br>Dimmer/strobe for monochromatic ribbons |
| Dimensions                    | 86x86x16 mm   |
| Poids                         | 100 g   |

This simple, intuitive and touch-sensitive driver grants you access to many settings such as your favourite programs. It really is a 2-in-1 system: this is both a 3-channel DMX driver and 24V RGB converter.

It is able to control any DMX device (3 channels) or directly power up RGB or monochromatic ribbons (with adequate power supply).



### TOUCH-SENSITIVE WIFI (2,4 GHz) AND DMX DRIVERS

The PILOTctl wall-mount drivers are touch-sensitive command interfaces only. DMX information can be transmitted wirelessly via Wi-Fi, but also via cable. Once combined with appropriate ribbon drivers, they allow you to control your ribbons installation. Useful for monochromatic gradation, colour temperature settings, RGB, RGBW and 4-zone RGBW control.



2,4 GHz DMX 1CH

PILOTctl-1- Ref 10564

|                 |   |
|-----------------|---|
| Function        | 5 % to100 % monochromatic dimmer<br>Direct access to a saved scene<br>« 30S » Ribbon turns off after 30 s |
| Format          | Wall-mountable  |
| Power supply    | 240 V   |
| Outgoing signal | 2,4 Ghz & DMX512  |
| Operating range | 30 m on 2,4 GHz   |
| Dimensions      | 112 x 112 x 48 mm   |
| Weight          | 225 g   |



2,4 GHz DMX 2 CH

PILOTctl-2- Ref 10565

|                 |   |
|-----------------|---|
| Function        | Warm/cold white dimmer 5 % to 100 %<br>Direct access to a saved scene<br>« Mode » to switch between cold and warm |
| Format          | Wall-mountable  |
| Power supply    | 240 V   |
| Outgoing signal | 2,4 Ghz & DMX512  |
| Operating range | 30 m on 2,4 GHz   |
| Dimensions      | 112 x 112 x 48 mm   |
| Weight          | 225 g   |



2,4 GHz 4 CH

### CONTROL LIGHTS IN YOUR ROOM WITH YOUR TAPE-DRIVER-WIFI4

TAPEDRIVER-WIFI4 (ref 10580) is a ribbon driver compatible with touch-sensitive PILOTctl series drivers. Its role is to receive 2,4 GHz DMX information transmitted by the driver and control the power sent to LED ribbons (480W Max at 24V). Assignment is really easy, and you can use several TAPEDRIVER-WIFI-4 with a single PILOTctl.



2,4 GHz DMX 3 CH



2,4 GHz DMX 4 CH

PILOTctl-3- Ref 10566

|                 |  |
|-----------------|--|
| Function        | 5 % to 100 % RGB dimmer<br>Direct access to a saved scene<br>11 preset modes |
| Format          | Wall-mountable   |
| Power supply    | 240 V  |
| Outgoing signal | 2,4 Ghz & DMX512   |
| Operating range | 30 m on 2,4 GHz  |
| Dimensions      | 112 x 112 x 48 mm  |
| Weight          | 225 g  |

PILOTctl-4- Ref 10567

|                 |  |
|-----------------|--|
| Function        | 5 % to 100 % RGBW dimmer<br>Direct access to a saved scene<br>12 preset modes - Direct access to white |
| Format          | Wall-mountable   |
| Power supply    | 240 V  |
| Outgoing signal | 2,4 Ghz & DMX512   |
| Operating range | 30 m on 2,4 GHz  |
| Dimensions      | 112 x 112 x 48 mm  |
| Weight          | 225 g  |

The solution for recessed controllers

PILOTBOX - ref 10637  
Square flush-mounted box  
47 mm white



PILOTSCREW - ref 10638  
Steel screw size M3.5x20 - 1 piece

4 ZONES 2,4 GHz DMX 4x4 CH

PILOTctl-16- Ref 10568

|                 |  |
|-----------------|--|
| Function        | 5 % to 100 % RGBW dimmer<br>Direct access to a saved scene<br>12 preset modes - Direct access to white |
| Format          | Wall-mountable   |
| Power supply    | 240 V  |
| Outgoing signal | 2,4 Ghz & DMX512   |
| Operating range | 30 m on 2,4 GHz  |
| Dimensions      | 112 x 112 x 48 mm  |
| Weight          | 225 g  |



**4 ZONES CONTROLLED VIA TAPEDRIVER-WIFI4 AND PILOTctl-16**

PILOTctl-16 can control up to 4 zones equipped with RGBW LED ribbons.  
To do so, all you need is to assign one or several TAPEDRIVER-WIFI4 to selected zones and then control your whole installation with a single touch-sensitive interface.



SETUP EXAMPLE FOR BOWLING ALLEY

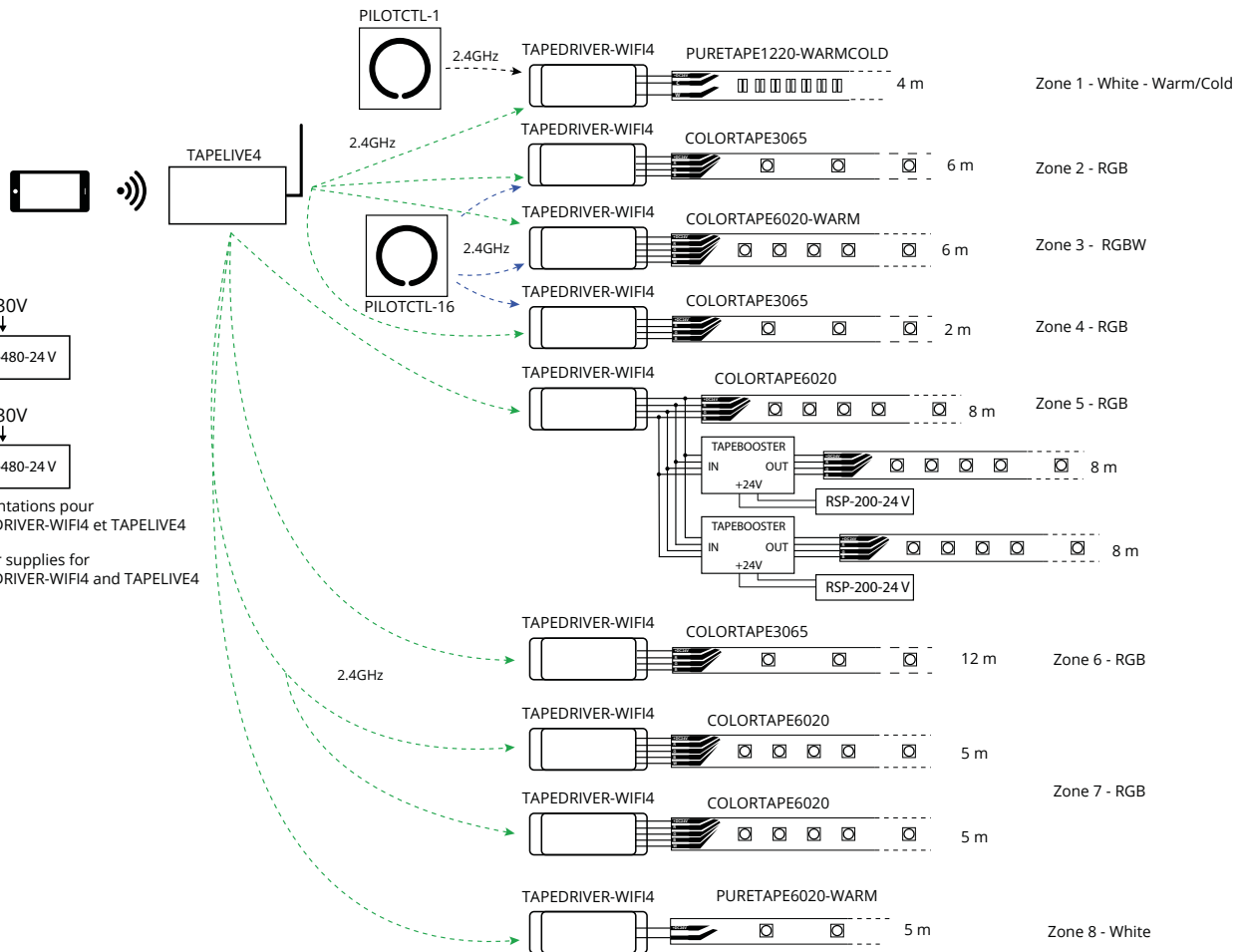
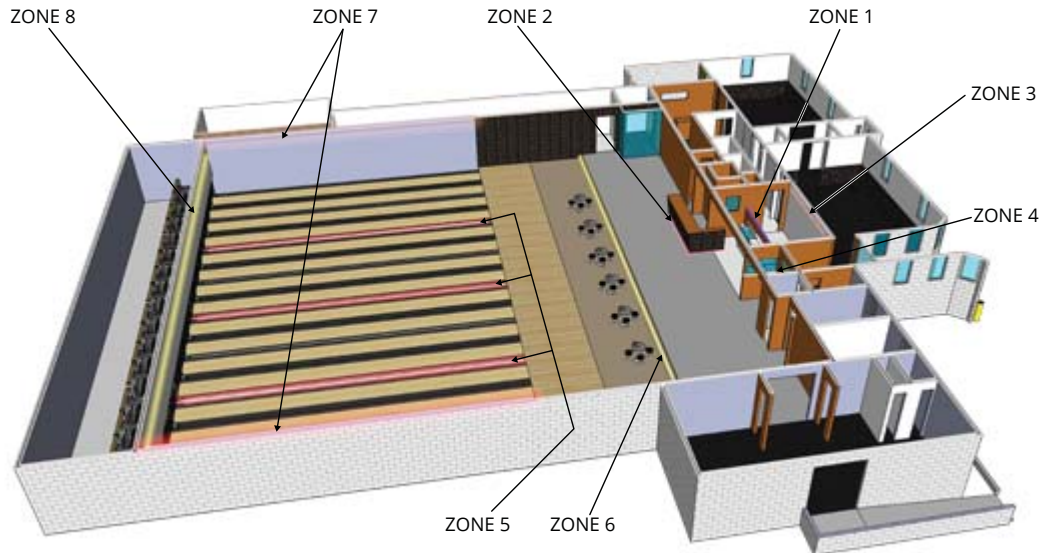

AVAILABLE ON APPLE STORE AND GOOGLE PLAY

// Suits all kinds of lights // 12 zones for 3 groups max. // Scenes creation



Take control of your installation with this dedicated application. It allows you to control up to 12 zones of any kind of ribbons, create 3 groups of zones with the same type of ribbons, but also save and modify up to 4 scenes endlessly.







**WIFI TRANSMITTER RECEIVER FOR TAPEDRIVER-WIFI4 DRIVER WITH REMOTE CONTROL**

// 2.4 GHz Wi-Fi Receiver / Transmitter // Compatible with up to 12 TAPEDRIVER-WIFI4 // Controllable via smartphone and remote control

TAPELIVE4 - Ref 10572

|                               |   |
|-------------------------------|---|
| Communication via             | 2.4 GHz Wi-Fi, 802.11b/g/n protocol                         |
| Power supply                  | 12-24 V DC  |
| Operating range               | 100m (depending on environment) in open field, with a phone |
| Intensity (Max load. in Amps) | 4 A x 4 (outputs) = 16 A max                                |
| Power                         | 192 W / 384 W (12 V / 24 V)                                 |
| Dimensions                    | 128 x 73 x 45 mm  |
| Weight                        | 382 g   |

Remote control (supplied with TAPELIVE4)

|                   |                      |
|-------------------|----------------------|
| Communication via | 2.4GHz               |
| Power supply      | DC3V(CR2032 battery) |
| Operating range   | 25 m                 |
| Dimensions        | 104 x 60 x 9         |
| Weight            | 42 g                 |









**2 OPERATING MODES FOR YOUR TAPELIVE4**

TAPELIVE4 can be autonomous (power mode) or wireless, connected to TAPEDRIVER-WIFI4 and using a router to connect several TAPELIVE4.

**DRIVER WIFI POUR TAPELIVE4 AND PILOTCTL**

// 2,4 GHz Receiver // High power at 24 V (480 W)

TAPEDRIVER-WIFI4 - Ref 10580

|                               |  |
|-------------------------------|--|
| Communication via             | 2.4GHz Wi-Fi                             |
| Power supply                  | 5 - 24 V DC                              |
| Operating range               | 30 m                                     |
| Intensity (Max load. in Amps) | 5 A x 4 (outputs) = 20 A max             |
| Power                         | 100 W / 240 W / 480W (5 V / 12 V / 24 V) |
| Dimensions                    | 175 x 44 x 30 mm                         |
| Weight                        | 150 g                                    |







**WHAT LENGTH OF RIBBON FOR TAPEDRIVER-WIFI4 ?**

You can use up to 20 metres of RGBW COLORTAPE6067-WARM or COLORTAPE6020-WARM ribbons. If all recommendations are observed

REMOTE CONTROLS

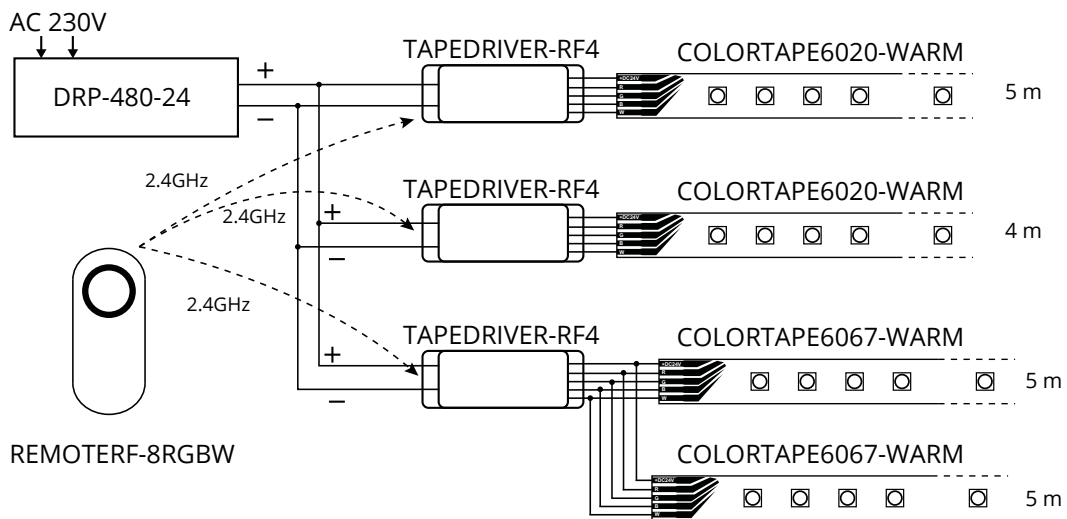

|                            | REMOTERF-8W (Ref 10569) | REMOTERF-10RGB (Ref 10570)                          | REMOTERF-8RGBW (Ref 10571) |
|----------------------------|-------------------------|---|----------------------------|
| Communication via          |                         | 2.4GHz  |                            |
| Power supply               |                         | 5V DC (Lithium) - Rechargeable battery via mini USB |                            |
| Number of zones controlled | 8 zones                 | 10 zones  | 8 zones                    |
| Compatible drivers         | TAPEDRIVER-RF3          | TAPEDRIVER-RF3 & TAPEDRIVERTOUCH-RF3                | TAPEDRIVER-RF4             |
| Operating range            |                         | 30 m  |                            |



**NO CABLE BETWEEN OUR DRIVERS**

Our drivers do not connect to each other via cable. Information sent via the remote control use the Wi-fi 2,4 GHz technology to automatically synchronize with the drivers.



### 2,4 GHz RGB RIBBONS DRIVER

// 2,4GHz Receiver // Very high power: 432 W ( 24 V ) // Compatible with REMOTERF-8W & REMOTERF-10RGB remote controls

TAPEDRIVER-RF3 - Ref 10577

|                               |  |
|-------------------------------|--|
| Communication via             | 2.4 GHz                                  |
| Power supply                  | 5 - 24 V DC                              |
| Intensity (Max load. in Amps) | 6 A x 3 (outputs) = 18 A max             |
| Power                         | 90 W / 216 W / 432 W (5 V / 12 V / 24 V) |
| Compatible remote controls    | REMOTERF-8W & REMOTERF-10RGB             |
| Operating range               | 30 m                                     |
| Dimensions                    | 175 x 44 x 30 mm                         |
| Weight                        | 150                                      |



TAPEDRIVER-RF3 is a 3-channel ribbon driver compatible with REMOTRF-8W and REMOTERF-10RGB. It allows you to receive information transmitted by the remote control and adjust the power of your monochromatic or RGB LEDs ribbons (432W Max at 24V). Its LED indicator will help you check your installations.

### MANUAL, 2,4 GHz RGB RIBBONS DRIVER

// Manual driver receiving via 2,4GHz // High power: 360 W ( 24 V ) // Compatible with REMOTERF-10RGB remote control

TAPEDRIVERTOUCH-RF3 - Ref 10578

|                               |                              |
|-------------------------------|------------------------------|
| Communication via             | 2.4 GHz                      |
| Power supply                  | 12 - 24 V DC                 |
| Intensity (Max load. in Amps) | 5 A x 3 (outputs) = 15 A max |
| Power                         | 180 W / 360 W (12 V / 24 V)  |
| Compatible remote controls    | REMOTERF-10RGB               |
| Operating range               | 30 m                         |
| Dimensions                    | 211 x 40 x 30                |
| Weight                        | 180 g                        |



TAPEDRIVERTOUCH-RF3 is a 3-channel ribbon driver compatible with REMOTERF-10RGB. It can also be use via its touch-sensitive buttons. You will then be able to select colours, colour macros, adjust the speed and light output: this is perfect if you do not need to command your installation remotely. (360W Max en 24V)

### 2,4 GHz RGBW RIBBONS DRIVER

// 2,4GHz Receiver // High power: 480 W ( 24 V ) // Compatible with REMOTERF-8RGBW remote control

TAPEDRIVER-RF4 - Ref 10579

|                               |   |
|-------------------------------|---|
| Communication via             | 2.4 GHz                                   |
| Power supply                  | 5 - 24 V DC                               |
| Intensity (Max load. in Amps) | 5 A x 4 (outputs) = 20 A max              |
| Power                         | 100 W / 240 W / 480 W (5 V / 12 V / 24 V) |
| Compatible remote controls    | REMOTERF-8RGBW                            |
| Operating range               | 30 m                                      |
| Dimensions                    | 175 x 44 x 30 mm                          |
| Weight                        | 150 g                                     |



TAPEDRIVER-RF4 is a 4-channel ribbon driver controlled via REMOTERF-8RGBW. It receives information sent via the remote control and generate power for RGBW ribbons. (480W Max at 24V)

Its LED indicator will help you check your installations.

## DMX DRIVERS

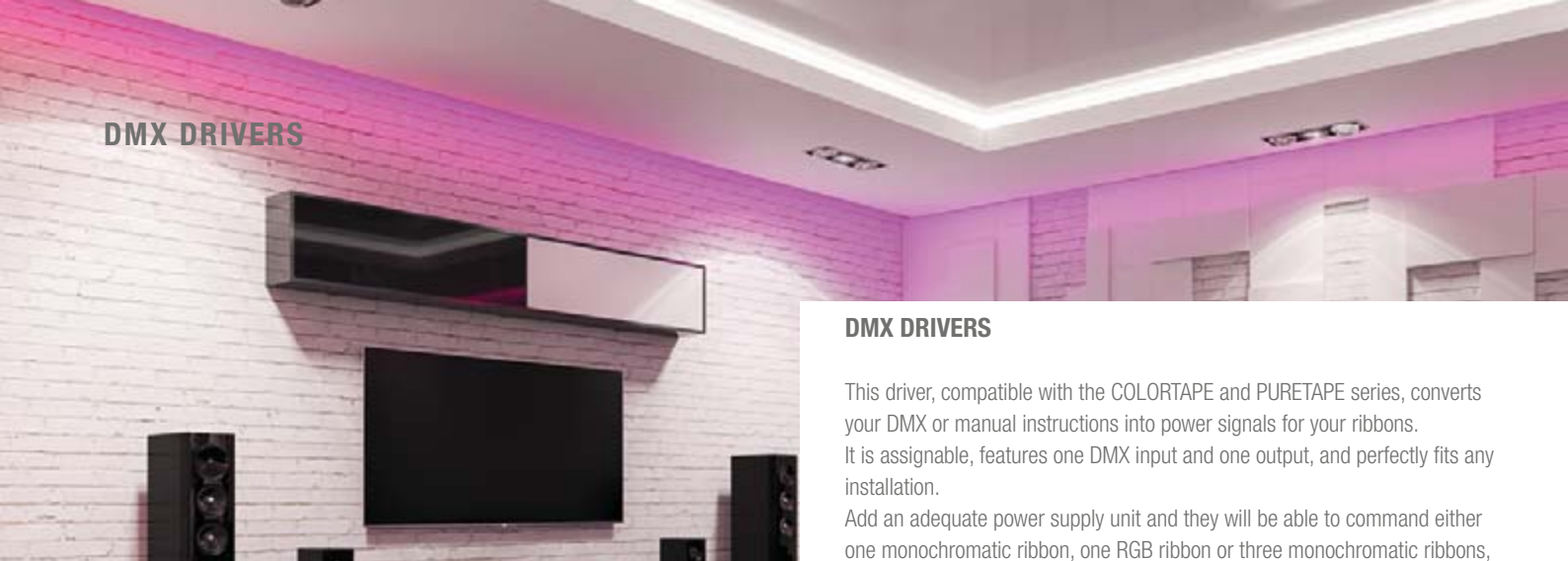

152

### DMX DRIVERS

This driver, compatible with the COLORTAPE and PURETAPE series, converts your DMX or manual instructions into power signals for your ribbons. It is assignable, features one DMX input and one output, and perfectly fits any installation.

Add an adequate power supply unit and they will be able to command either one monochromatic ribbon, one RGB ribbon or three monochromatic ribbons, one RGBW ribbon or four monochromatic ribbons.

#### DMX DRIVER FOR MONOCHROMATIC RIBBON

TAPEDRIVER-1 - Ref 10573

// For monochromatic ribbon  
 // 1 DMX channel  
 // 144 W at 24 V  
 // Dimmer via dipswitches  
 // 0-10V command



#### DRIVER DMX POUR RUBAN RGB

TAPEDRIVER - Code 9867

// For RGB ribbon & monochromatic  
 // 3 DMX channels  
 // 96 W at 24 V  
 // Program and colour selection via dipswitches



#### DMX DRIVER FOR RGB RIBBON

TAPEDRIVER-3 - Ref 10574

// For RGB ribbon  
 // 3 DMX channels  
 // 144 W at 24 V  
 // Program and colour selection via dipswitches



#### DMX DRIVER FOR RGBW RIBBON

TAPEDRIVER-4 - Ref 10575

// For RGBW ribbon  
 // 4 DMX channels  
 // 240 W at 24 V  
 // Program and colour selection via dipswitches



#### DMX FUNCTIONS

e.g. with one RGB ribbon  
 (3 channels)

Dimmer 1: Red 0%-100%

Dimmer 2: Green  
 0%-100%

Dimmer 3: Blue 0%-100%

TAPEDRIVER-1 - Ref 10573

TAPEDRIVER - Ref 9867

TAPEDRIVER-3 - Ref 10574

TAPEDRIVER-4 - Ref 10575

TAPEDRIVER12 - Ref 10576

|                               |                             |  |   |   |  |
|-------------------------------|-----------------------------|--|---|---|--|
| Power supply                  | 12 - 24 V DC                | 6- 24 V DC                             | 12 - 24 V DC  | 12 - 24 V DC  | 12 - 24 V DC on 2 inputs   |
| Number of channels            | 1 DMX channel               | 3 DMX channels                         | 3 DMX channels                                      | 4 DMX channels                                      | 12 DMX channels  |
| Intensity (Max load. in Amps) | 6 A x 1 (output) = 6 A max  | 1,3A x 3 (output) = 4 A max            | 2A x 3 (output) = 6 A max                           | 2,5 A x 4 (output) = 10 A max                       | 5 A x 12 (output) = 60 A max   |
| Power                         | 72 W / 144 W ( 12 V / 24 V) | 30W / 96 W ( 6 V / 24 V)               | 72 W / 144 W ( 12 V / 24 V)                         | 120 W / 240 W ( 12 V / 24 V)                        | 720 W / 1440 W ( 12 V / 24 V)  |
| Modes                         | DMX 512                     | DMX512 - Fixed colours via dipswitches | DMX512 - Fixed colours via dipswitches and programs | DMX512 - Fixed colours via dipswitches and programs | DMX 512  |
| Connectors                    | Phoenix                     | Sur fiches Phoenix                     | Phoenix   | Phoenix   | Power supply input and ribbon output via terminals<br>DMX IN OUT via 3-pin XLR and RJ45 connectors |
| Dimensions                    | 90 x 40 x 20 mm             | 90 x 40 x 20 mm                        | 90 x 40 x 20 mm                                     | 115 x 55 x 25 mm                                    | 225 x 110 x 43   |



**12-CHANNEL DMX DRIVER FOR ALL RIBBONS**

TAPEDRIVER12 - Ref 10576

// For ribbons 24 V  
// 12 DMX channels  
// 1440 W at 24 V



**STAND-ALONE DIMMER AND BOOSTER**

**DIMMER FOR MONOCHROMATIC RIBBON**

// For monochromatic ribbon // Light output control // No welding required

TAPEDIMMER - Ref 9866

|               |                          |
|---------------|--------------------------|
| Power supply  | 24 V DC                  |
| Power input   | 24 V DC, 432 W max       |
| Ribbon output | 24 V DC, 432W max, 400Hz |
| Power         | 432 W (24 V)             |
| Connectors    | Phoenix                  |
| Dimensions    | 112 x 65 x 24 mm         |



Adjust manually the output of your PURETAPE-WARM and COLD ribbons with this intuitive and easy-to-install dimmer.

Add an adequate power supply unit to command up to 432W of 24V PURETAPE, all within an ultra-compact format.

**BOOSTER FOR MONOCHROMATIC AND RGB RIBBONS**

// Compatible with RGB and monochromatic ribbons // Boost your signal without altering your colours or light output // Require 24V battery

TAPEBOOSTER - Ref 9865

|              |                  |
|--------------|------------------|
| Power supply | 24 V DC          |
| Power        | 3 x 8A 576 W     |
| Connectors   | Phoenix          |
| Dimensions   | 107 x 65 x 24 mm |



This booster is compatible with our COLORTAPE RGB and PURETAPE series, and allows you to increase the number of ribbons daisy-chained via a single driver.

Add an adequate power supply unit and it will amplify the received signal to connect more ribbons to the same driver, allowing you to use more ribbons while preserving a uniform light output.

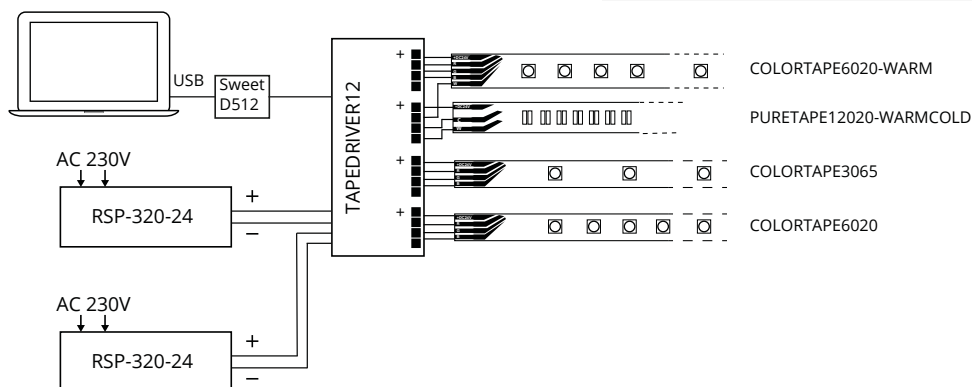

**50 W POWER AND CONTROL UNIT**

- // AUTO and DMX modes // AUTO mode : Music-sensitive
- // Connectors adapted to the CTLTAPE wall controle
- // You can operate it via a wall controler



The POWTAPE offers control and supplies power to the LED ribbons series. It is the easiest way to set them up.

**WALL CONTROLER FOR A POWTAPE POWER SUPPLY UNIT**

- // Compact // DMX 4 channels
- // Colour management, dimmer/strobe and programs (for tricolour ribbons)
- // Dimmer/strobe control (for monochromatic ribbons)



Wall controler for a POWTAPE power supply. The CTLTAPE controller is not directly plugged into the LED ribbon.

154

POWTAPE - Code 9583

|                    |   |
|--------------------|---|
| Power supply       | AC230V - 50 Hz  |
| Number of channels | 3 channels DMX  |
| Power              | 50 W max (16 W per output channel)                    |
| Modes              | Master / Slave - fixed colours -Music - Various modes |
| Ip protection      | IP20  |
| Dimensions         | 332 x 70 x 40 mm                                      |



**POW121**  
**Power Supply for**  
**CTLTAPE**  
**12VDC - 1A**  
**Ref 9806**

CTLTAPE - 9584

|                    |                          |
|--------------------|--------------------------|
| Power supply       | DC12V - 1A (non fournie) |
| Numbers of channel | 4 channels DMX           |
| Protection IP      | IP20                     |
| Dimensions         | 332 x 70 x 40 mm         |

**POWER SUPPLIES**

Safety instructions:  
RSP and LRS series power supply units are designed to be integrated into installations.  
A security perimeter must be set to ensure they are out of reach and protected from any contact.



POW241IP



POW242



POW244IP2



LRS-100-24



DR120-24



POW246IP2



RSP-200-24



DRP-240-24



RSP-320-24



DRP-480-24

| Name       | Ref   | Power output | Intensity | Power | Number of outputs | Format        | IP   | Dimensions          |
|------------|-------|--------------|-----------|-------|-------------------|---------------|------|---------------------|
| POW241IP   | 9881  | 24VDC        | 1 A       | 30 W  | 1                 | -             | IP65 | 218 x 30 x 22       |
| POW121     | 9806  |              | 1 A       |       | -                 | -             | IP20 |                     |
| POW242     | 9807  |              | 2,1 A     | 50 W  | 1                 | -             | IP20 | 125 x 52 x 36       |
| POW244IP2  | 10362 |              | 4 A       | 100 W | 2                 | -             | IP65 | 240 x 68 x 57       |
| LRS-100-24 | 10581 |              | 4,5A      | 100 W | 2                 | To integrated | IP20 | 129 x 97 x 30       |
| DR120-24   | 9926  |              | 5A        | 120 W | 2                 | Rail          | IP20 | 65,5 x 125,2 x 100  |
| POW246IP2  | 10316 |              | 6,5A      | 150 W | 2                 | -             | IP65 | 240 x 68 x 57       |
| RSP-200-24 | 10582 |              | 8,4A      | 200 W | 3                 | To integrated | IP20 | 215 x 115 x 30      |
| DRP-240-24 | 9927  |              | 10 A      | 240 W | 2                 | Rail          | IP20 | 125,5 x 125,2 x 100 |
| RSP-320-24 | 10583 |              | 13,4 A    | 320 W | 3                 | To integrated | IP20 | 215 x 115 x 3       |
| DRP-480-24 | 9928  |              | 20 A      | 480 W | 2                 | Rail          | IP20 | 227x125,2x100       |



TAPEprofil-A

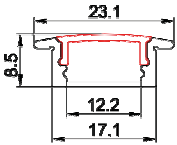

TAPEprofil-B

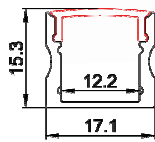

TAPEprofil-C

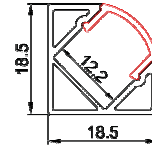

TAPEprofil-D

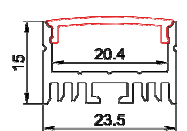

**PROFILES**

|                             |   |           |                           |                            |                           |                       |
|-----------------------------|---|-----------|---------------------------|----------------------------|---------------------------|-----------------------|
| TAPEprofil-A<br>Ref : 10619 | Aluminium recessed profile 9x17 mm      | Lenght 2m | -                         | -                          | TAPEcaps-A<br>Ref : 10629 | End cap for profile A |
| TAPEprofil-B<br>Ref : 10620 | Aluminium profile 15x17 mm              | Lenght 2m | TAPEclip-B<br>Ref : 10633 | Fixture clip for profile B | TAPEcaps-B<br>Ref : 10630 | End cap for profile B |
| TAPEprofil-C<br>Ref : 10621 | Aluminium profile 45° 19x19 mm          | Lenght 2m | TAPEclip-C<br>Ref : 10634 | Fixture clip for profile C | TAPEcaps-C<br>Ref : 10631 | End cap for profile C |
| TAPEprofil-D<br>Ref : 10622 | Double-width aluminium profile 15x24 mm | Lenght 2m | TAPEclip-D<br>Ref : 10635 | Fixture clip for profile D | TAPEcaps-D<br>Ref : 10632 | End cap for profile D |



Crystal



Frost

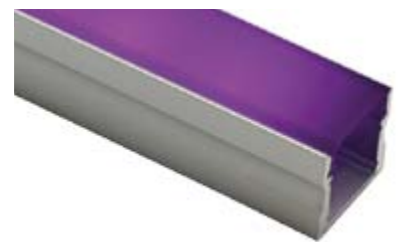

Milk

**COVERS**

|         | Profile A, B, C          |           | Profile D                |           |
|---------|--------------------------|-----------|--------------------------|-----------|
| Crystal | TAPEcov-1<br>Ref : 10623 | Lenght 2m | TAPEcov-4<br>Ref : 10626 | Lenght 2m |
| Frost   | TAPEcov-2<br>Ref : 10624 | Lenght 2m | TAPEcov-5<br>Ref : 10627 | Lenght 2m |
| Milk    | TAPEcov-3<br>Ref : 10625 | Lenght 2m | TAPEcov-6<br>Ref : 10628 | Lenght 2m |

Compatibility Guide

















Code

PURETAPE6020-WARM  
PURETAPE14420-WARM  
PURETAPE6020-COLD  
PURETAPE14420-COLD

PURETAPE12020-WARMCOLD  
PURETAPE12067-WARMCOLD

COLORTAPE6067  
COLORTAPE6065  
COLORTAPE3065  
COLORTAPE6020

COLORTAPE6020-WARM  
COLORTAPE6067-WARM

|  |                     |       |   |   |   |   |
|--|---------------------|-------|---|---|---|---|
|   | PILOTdrive-1        | 10560 | ✓ | - | - | - |
|   | PILOTdrive-2        | 10561 | - | ✓ | - | - |
|   | PILOTdrive-3        | 10562 | - | - | ✓ | - |
|   | PILOTdrive-4        | 10563 | - | - | - | ✓ |
|   | PilotTOUCH          | 9809  | - | - | ✓ | - |
|  | TAPEDIMMER          | 9866  | ✓ | - | - | - |
|  | TAPEDRIVER-1        | 10573 | ✓ | - | - | - |
|  | TAPEDRIVER-3        | 10574 | ✓ | ✓ | ✓ | - |
|  | TAPEDRIVER-4        | 10575 | ✓ | ✓ | ✓ | ✓ |
|  | TAPEDRIVER-12       | 10576 | ✓ | ✓ | ✓ | ✓ |
|  | TAPEDRIVER-RF3      | 10577 | ✓ | - | ✓ | - |
|  | TAPEDRIVERTOUCH-RF3 | 10578 | - | - | ✓ | - |
|  | TAPEDRIVER-RF4      | 10579 | - | - | - | ✓ |
|  | TAPEDRIVER-WIFI4    | 10580 | ✓ | ✓ | ✓ | ✓ |
|  | TAPELIVE4           | 10572 | ✓ | ✓ | ✓ | ✓ |



|   |   |   |   |   |   |   |   |   |   |   |   |   |  |   |   |   |   |   |   |
|---|---|---|---|---|---|---|---|---|---|---|---|---|--|---|---|---|---|---|---|
|  |  |  |  |  |  |  |  |  |  |  |  |  |  |  |  |  |  |  |   |
| REMOINTERF-8W<br>10569  | REMOINTERF-10RGB<br>10570   | REMOINTERF-8RGBW<br>10571   | PILOTctl-1<br>10564   | PILOTctl-2<br>10565   | PILOTctl-3<br>10566   | PILOTctl-4<br>10567   | PILOTctl-16<br>10568  | Pilot-TOUCH<br>9809   | Téléphone/Tablette  | TAPEDRIVER-RF3<br>10577   | TAPEDRIVERTOUCH-RF3<br>10578  | TAPEDRIVER-RF4<br>10579   | TAPEDRIVER-WIFI4<br>10580  | TAPELIVE4<br>10572  | TAPEDRIVER1<br>10573  | TAPEDRIVER3<br>10574  | TAPEDRIVER4<br>10575  | TAPEDRIVER12<br>10576   |   |
| ✓   | ✓   | -   | -   | -   | -   | -   | -   | -   | -   | -   | ✓   | -   | -  | -   | -   | -   | -   | -   | ✓ |



Ref 10546 - FLATCABLE-4 - Flat cable 4 x 0,326mm<sup>2</sup> N/V/R/B - 10m



Ref 10547 - FLATCABLE-5 - Flat cable 5 x 0,326mm<sup>2</sup> N/V/R/B/J - 10m



**IP65 AND IP67 SERIES**

TAPELINK61 4-wire cord with black IP61 connectors (≈ 40 cm) ref 9884



TAPELINK65 4-wire cord with IP65 transparent connectors (≈ 40 cm) ref 9885



TAPELINK68 4-wire cord with white IP68 connectors (≈ 40 cm) ref 9886



TAPEFIX68 15 saddles, 5 caps, 1 silicone tube kit ref 9882

**IP65 SERIES ONLY**



TAPELINK20 4-wire cords with connectors for IP20 ribbon (≈ 40 cm) ref 9887



TAPECON4FF Bag of 20 4-wire female/female connectors for IP20 ribbon ref 9888



TAPEFIX65 Kit containing 15 eye straps, 5 caps, and 1 silicone protective sleeve ref 9883

**ADHÉSIF**



ADF1050 10 mm double-face adhesive tape - 50 m ref 10544

ADF1250 12 mm double-face adhesive tape - 50 m ref 10545



RGBB-100 - Ref 9808

RGB +black power cord for a COLORTAPE power supply - 50 m



PILOTBOX - ref 10637 Square flush-mounted box 47 mm white

PILOTSCREW - Steel screw size M3.5x20 - 1 piece

**CONNECTORS L, T,X**

| Monochromatic ribbon |   | Two-coloured ribbon |  |
|----------------------|---|---------------------|--|
| 10548                | LCO-2 - L connector for monochromatic ribbon - 10mm | 10551               | LCO-3 - L connector for two-coloured ribbon - 10mm |
| 10549                | TCO-2 - T connector for monochromatic ribbon - 10mm | 10552               | TCO-3 - T connector for two-coloured ribbon - 10mm |
| 10550                | XCO-2 - X connector for monochromatic ribbon - 10mm | 10553               | XCO-3 - X connector for two-coloured ribbon - 10mm |
| RGB ribbon           |   | RGBW ribbon         |  |
| 10554                | LCO-4 - L connector for RGB ribbon - 10 mm          | 10557               | LCO-5 - L connector for RGBW ribbon - 12mm         |
| 10555                | TCO-4 - T connector for RGB ribbon - 10 mm          | 10558               | TCO-5 - T connector for RGBW ribbon - 12mm         |
| 10556                | XCO-4 - X connector for RGB ribbon - 10 mm          | 10559               | XCO-5 - X connector for RGBW ribbon - 12mm         |



# CEIL 6TC-MKII

ref 10658

Waterproof projector with 6 x 3W RGB LEDs, supplied with fixation bracket.  
Connection via RJ45 socket to the PILOT series power supply units.  
No end link connector required for the last device or your chain.



159

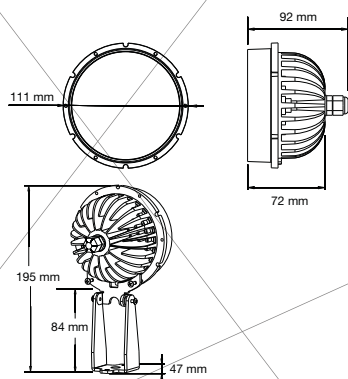

## PILOT SERIES

The CEIL6TC-MKII use the power and control units of the PILOT series.

See page 161

### TECHNICAL SPECIFICATIONS

- Optical:
  - 6 x 3W trichromatic LEDs
  - Lenses have been equipped with a filter for a better diffusion
  - Almost infinite variety of shades without reflects from phantom colours
  - No infrared or UV emission
  - LEDs lifespan: 25 000 hours at full power
  - Flux (Lm): 590 +/- 2.5%
  - Efficiency (Lm/W): 33
  - Light output: 266 Lux at 3m in white
- Housing:
  - Extruded aluminium body
  - Convection-cooled

- Waterproof cable gland
- IP tightness: 65 (fully protected against dust and water splashes)
- Technical specifications:
  - Power supply: 12-48V, DC 350 mA (max) /48V
  - Power consumption: 18 W
  - Compatible power supply and control units: PILOT60/120/240
  - Cable: 1 m Cat.5e with 8-pin RJ45 connector
  - Operating temperature: -10°C ~ 40°C
  - Dimensions:
    - Diameter 111 mm
    - Length 72 mm (without cable gland) / 92 mm (with cable gland)
  - Weight: 245g

# CEIL 3TC-MKII

ref 10492



160

3x3W tricolor LEDs waterproof projector supplied with a holding bracket compatible with MR16 fittings. It can be connected via RJ45 to any PILOT power units.

## TECHNICAL SPECIFICATIONS

- Optical :
  - 3 x 3 W trichromatic LEDs
  - Light output: 120 Lux at 3m in white
  - Beamwidth: 40°
  - Flux (Lm): 210 +/- 2.5%
  - Efficiency (Lm/W): 14
- Materials :
  - Extruded aluminium housing
  - MR16 support compatible
- Tightness level :

- 65 IP (fully waterproof and perfectly protected against dusty residues)
- Technical specifications :
  - Power supply : DC48 V 350 mA (max) 12 W
  - Compatible power and control units :
    - PILOT60/120/240
  - Cable :
    - 0.25 m Cat.5 with a 8-pin RJ45 connector
  - Measurements :
    - Diameter 50 mm (MR16 compatible) x length 85 mm
  - Weight : 0.4 kg

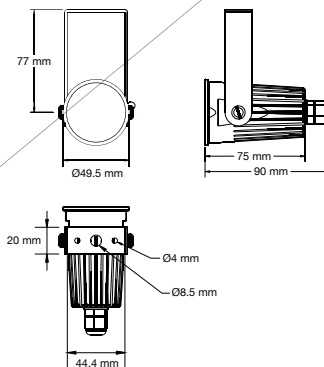

1, 2, 3, 4, 5, 6 : RJ45 connection cable for projectors.



8 : End connector for CEIL3TC-MKII CEIL6TC-MKII projectors.



10 : RJ45 plug with black sleeve.



7 : Junction box with RJ45 sockets.



9 : Waterproof distribution box with integrated labelled connectors.



11 : Crimping tool for RJ45 plugs.



12 : Category 5 cable for RJ45 connectors allowing custom-made connections.

|    | REFERENCE   | DESCRIPTION   | REF  |
|----|-------------|---|------|
| 1  | LINK-RJ15   | RJ45-RJ45 connection cable - 0.15 m                       | 9786 |
| 2  | LINK-RJ50   | RJ45-RJ45 connection cable - 0.5 m                        | 9787 |
| 3  | LINK-RJ150  | RJ45-RJ45 connection cable - 1,5 m                        | 9788 |
| 4  | LINK-RJ300  | RJ45 connection cable-RJ45 - 3 m                          | 9789 |
| 5  | LINK-RJ500  | RJ45-RJ45 connection cable - 5 m                          | 9790 |
| 6  | LINK-RJ1000 | RJ45-RJ45 connection cable - 10 m                         | 9791 |
| 7  | LINK-SPLIT  | 1IN/1LED/1OUT distribution box<br>• RJ45 conn.            | 9792 |
| 8  | LINK-END    | RJ45 End link connector to close a chain                  | 9793 |
| 9  | LINK-IPBOX  | Waterproof distribution box<br>• internal conn.<br>• IP68 | 9803 |
| 10 | LINK-SOCKET | RJ45 plug with black sleeve                               | 9804 |
| 11 | LINK-TOOL   | Crimping tool for RJ45 plugs                              | 9805 |
| 12 | CAT5e-100   | 24AWG Power/Data cable - 100 m                            | 9802 |



# PILOT SERIES

Power and control units for LEDs projectors with RJ45 connectors.



161

## PILOT240

ref 9782

Control 4x60W zones, up to a maximum of 240W. A schedule is available to make it work automatically.

## PILOT120

ref 9781

Control 2x60W zones, up to a maximum of 240W.

## PILOT60

ref 9780

Control a projector group, up to a maximum of 60W.

- Schedule :
  - Choose 30 scenes among the different programs
  - Daily schedule
  - Program the start/end time

### TECHNICAL SPECIFICATIONS

|                              | PILOT240                              | PILOT120                              | PILOT60                               |
|------------------------------|---------------------------------------|---------------------------------------|---------------------------------------|
| Master/slave mode            | Yes                                   | Yes                                   | Yes                                   |
| Automatic                    | Yes                                   | Yes                                   | Yes                                   |
| Programmed schedule          | Yes                                   | -                                     | -                                     |
| Built-in programs            | 15                                    | 16                                    | 16                                    |
| Free space for user programs | 3                                     | 3                                     | 3                                     |
| Compatible projectors        | white and colours                     | white and colours                     | white and colours                     |
| RGBW channels                | 4 to 19                               | 4 to 11                               | 3 to 7                                |
| White or unicolor channels   | 4 to 8                                | 2 to 4                                | 1 to 2                                |
| RJ 45 48 V projector Outputs | 4 up to a maximum of 60 W per Zone    | 2 up to a maximum of 60 W per Zone    | 1 up to a maximum of 60 W per Zone    |
| Adaptator                    | RJ45/XLR for DMX connections supplied | RJ45/XLR for DMX connections supplied | RJ45/XLR for DMX connections supplied |
| Power supply                 | 100-240 V 50-60 Hz, AC                | 100-240 V 50-60 Hz, AC                | 100-240 V 50-60 Hz, AC                |
| Measurements                 | 280 x 309 x 90 mm                     | 234 x 279 x 62 mm                     | 179 x 215 x 60 mm                     |
| Net weight                   | 4 kg                                  | 2.4 kg                                | 1.4 kg                                |

### MAXIMUM NUMBER OF PROJECTORS PER CONTROL UNIT

|              | PILOT240 - 4 OUTPUTS OF 60W | PILOT120 - 2 OUTPUTS OF 60W | PILOT60 - 1 OUTPUT OF 60W |
|--------------|-----------------------------|-----------------------------|---------------------------|
| CEIL3TC-MKII | from 4 x 4 to 4 x 6         | from 2 x 4 to 2 x 6         | from 4 to 6               |
| CEIL6TC-MKII | from 4 x 2 to 4 x 3         | from 2 x 2 to 2 x 3         | from 2 to 3               |

**SAFETY PRECAUTIONS :** The maximum number of projectors per control unit depends on the length of the cables used. Long cable runs can consume up to 30% of the power generated by the control unit.

# GeyTEC - FazeTEC

Inspirés par la nature\*

\*Inspired by nature



Le geyser en couleur\*

\*Colourful geyser



La brume furtive\*

\*Furtive mist

by **Contest**® 

# FazeTEC

Fog machine

**A furtive haze machine**

ref 10204

The FazeTEC haze machine works non-stop and uses the Contest HD5L high density smoke fluid. Its large variable-speed fan allow you to create a very subtle smoke diffusion.

## TECHNICAL SPECIFICATIONS

### HAZE MACHINE

- Heater : 700W
- Pre-heat time : approximately 4 min
- Fluid tank : 1.3 litres
- Fog output : 85m3/min
- Max. fluid consumption : 3 ml/ min à 100%
- Uses the Contest HD5L high density smoke fluid

### CONTROL

- Control panel allowing you to control the output volume and the fan speed
- 2 DMX channels : Fog/fan

### ADDITIONAL CHARACTERISTICS

- Power supply : 230V - 50Hz
- Power consumption : 900W max.
- Measurements: 320 x 153 x 391 mm
- Net weight : 8.8 kg

- + Continuous output
- + Very silent
- + Long operating period



## CTL FazeTEC

Remote control  
ref 10246



# GeyTEC

LEDs geyser smoke machine

**When smoke becomes part of the show**

ref 10202

The Gey-TEC smoke machine, with its 22x3 Watts LEDs, is unlike any other. It is able to project an extremely powerful and tricolor smoke-jet vertically or horizontally.

**SMOKE PROJECTION: FROM 5 UP TO 7 METRES**

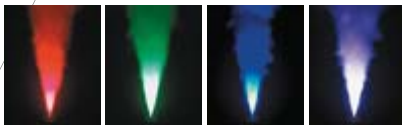

## TECHNICAL SPECIFICATIONS

### LIGHT SOURCE

- 22x3W LEDs
- 8 red, 7 green, 7 blue
- Average lifespan 30.000 hours

### SMOKE MACHINE

- Heater : 1550W
- Pre-heat time : approximately 5 min
- Fluid tank : 2.5 litres
- Max fluid consumption. : 25 ml/ 10s at 100%
- Uses the CONTEST® FD5L quick dissipating smoke liquid

- + Full colour smoke projector
- + A fast projection, immediate effect
- + HF remote control



### CONTROL

- HF remote control with 4 assignable buttons
- Control panel with transmission intervals control, LEDES control and smoke output control
- 8 DMX channels : Smoke/Red/Green/Blue/Chase/Master/Dimmer

### ADDITIONAL CHARACTERISTICS

- Can be used both vertically and horizontally
- Power supply : 230V - 50Hz
- Power consumption : 1600W max.
- Measurements : 340 x 195 x 380 mm
- Net weight : 10.9 kg



## FLY-GeyTECx2

Flight case for 2 GeyTEC smoke machines  
ref 10337



Light performers / Smoke machines

# HazeTEC

Consommation minimale  
la subtilité d'un voile\*

\*Minimum consumption  
As subtle as a veil



by **Contest**® 



# HazeTEC

1400W Fog Machine

**Materializing projector beams perfectly**

code 10487



- + Fast pre-heating (~46s)
- + Non-stop diffusion
- + Ventilation control
- + Liquid-saving

HazeTEC is a fog machine with non-stop diffusion, using the medium-density CONTEST® MD6L smoke fluid.

The exclusive design of its powerful coil heater allows a super-fast pre-heating and consistent smoke diffusion. Use its control panel or enter DMX mode to control the volume output and fan speed of your HazeTEC to spread smoke subtly and reduce the fluid consumption.



|   |            |
|---|------------|
| <b>MD6L</b>   | code 10491 |
| 6L can of CONTEST® medium density smoke liquid - HazeTEC only |            |

Note about the warranty:  
 The warranty of HAZETEC smoke machines is only valid if the MD6L smoke fluid only has been used.

## TECHNICAL SPECIFICATIONS

|  |   |
|--|---|
| Heater   | 1400W (pre-heating), 90W (when diffusing) |
| Pre-heating process  | 46 seconds approximately                  |
| Tank   | 6 litres                                  |
| Smoke output   | 99m3 per minute                           |
| 2 DMX channels   | Smoke/ventilation                         |
| Consumption max.   | 17ml par minute à 100%                    |
| Requires the MD6L CONTEST® medium density smoke liquid           |   |
| Control panel with smoke output and diffusion fan speed settings |   |
| Heater with automatic purge system                               |   |

|                            |                    |
|----------------------------|--------------------|
| Additional characteristics |                    |
| Power supply               | 230V - 50Hz        |
| Power consumption          | 1400W max.         |
| Dimensions                 | 343 x 364 x 280 mm |
| Net weight                 | 11.9 kg            |



## FLY-HAZETEC

Flightcase for HazeTec  
 Ref 10510

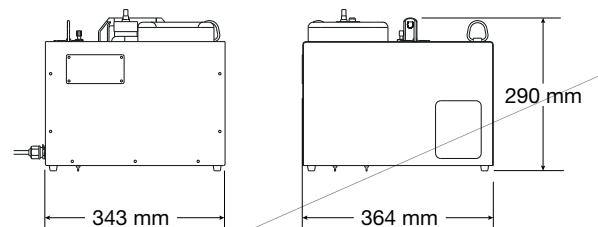

# Smotec800

Smoke machine

**Compact model, ideal to make light beams visible**

ref 9575

- + 800 W Heater
- + Smoke output : 85 m³/mn
- + Supplied with a timer-adjustable remote control



166

## TECHNICAL SPECIFICATIONS

|  |
|--|
| Smoke output : 85 m³/min   |
| Heater : 800 W   |
| Pre-heat time : 1.5 min  |
| Fluid tank : 0.8 l   |
| Average fluid consumption : 0.6 l/h  |
| Remote control options : timer programming and transmission intervals from 5 to 200 secondes |
| Power supply : 230 V - 50 Hz   |
| Power consumption : 900 W max.   |
| Measurements : 315 x 128 x 165,5 mm  |
| Net weight: 3,5 kg   |

## SMOKE FLUID

The ideal smoke fluid for the whole Contest® SMOTEC series.  
We recommend this liquid to be only used with the SMOTEC smoke machine series to guarantee better performances and a longer lifespan.

## GEYSER MACHINE FLUID

The ideal geyser fluid for the whole Contest® GeyTEC series.  
The GeyTEC geyser machines are only guaranteed if they use FD5L (ref 10203) liquid.

|   |          |
|---|----------|
| <b>HD5L</b>   | ref 9656 |
| 5L high density smoke fluid canister. Creates a very white and dense slow dissipating smoke. Leaves no oil residue. |          |



|                                  |           |
|----------------------------------|-----------|
| <b>FD5L</b>                      | ref 10203 |
| 5L geyser machine fluid canister |           |



Guarantees note :  
The SMOTEC smoke machines are only guaranteed if they use the HD5L fluid.

## SCENTS

Fluid scent additives - 10 scents available.

|                  |          |                |          |
|------------------|----------|----------------|----------|
| FLAG/ LEMON      | ref 4755 | FLAG/ LAVANDER | ref 4756 |
| FLAG/ COCONUT    | ref 4752 | FLAG/ MINT     | ref 4748 |
| FLAG/ FLOWER     | ref 4750 | FLAG/ APPLE    | ref 4751 |
| FLAG/ STRAWBERRY | ref 4757 | FLAG/ TROPICAL | ref 4754 |
| FLAG/ JASMINE    | ref 4749 | FLAG/ VANILLA  | ref 4753 |



# Smotec1000

DMX smoke machine

**Thanks to the Contest® SMOTEC1000 smoke fluid it produces a high quality, highly reliable smoke.**

ref 9576

- + 1000 W Heater
- + Smoke output : 283 m<sup>3</sup>/min
- + Supplied with 2 remote controls: wired (with a Timer) and wireless (On/Off)

## TECHNICAL SPECIFICATIONS

|   |
|---|
| Smoke output : 283 m <sup>3</sup> /min  |
| Heater : 1000 W   |
| Pre-heat time : 12 min  |
| Fluid tank : 2.8 L  |
| Average fluid consumption : 2,5 l/h à 100%  |
| Fluid quantities electronically-managed   |
| Remote control: Hertzian On / Off   |
| Remote control: timer programmation and transmission intervals from 5 to 200 secondes |
| DMX channels: 1   |
| Power supply : 230 V - 50 Hz  |
| Power consumption: 1100 W max.  |
| Measurements : 468 x 250 x 148 mm   |
| Net weight: 11.4 kg   |



167

# Smotec1500

DMX smoke machine

**This professional smoke machine features a Very powerful smoke output and countless options**

ref 9577

- + 1500 W Heater
- + Smoke output : 566 m<sup>3</sup>/min
- + Supplied with a HF remote control and a programmable control pad



## TECHNICAL SPECIFICATIONS

|  |
|--|
| Smoke output : 566 m <sup>3</sup> / min                                  |
| Heater : 1500 W  |
| Pre-heat time : 8 min  |
| Fluid tank : 10 l  |
| Max. fluid consumption : 8.6 litres / hour at 100%                       |
| Remote control : Hertzian On / Off                                       |
| Control pad with transmission intervals control and smoke output control |
| DMX channels : 1   |
| Power supply : 230 V - 50 Hz   |
| Power consumption : 1600 W max.  |
| Measurements : 668 x 319 x 170 mm  |
| Net weight: 15 kg  |

# PAR CONTROL 34

Auto

Mic

Shift

RGBW  
Colours

Color  
Select

Program

Sound  
Active

R

G

B

W

— Fade RGB / RGBW —

— Step RGB / RGBW —

Prog  
Select

Dimmer

Flash  
Speed

Speed /  
Sound  
Sensitivity

Black  
Out



# LIGHT CONTROL

# SWEET**Light**

Lighting DMX control software



MAC OS and Windows compatible

- + New version V8
- + New functions
- + User-friendly
- + Efficient
- + Powerful

170



Available in 6 languages

- An intuitive and easy handling interface with 3D visualisations
- Playful tools
- Low-resource software
- Built-in Contest® products
- Logiciel entièrement développé en France, manuel et didacticiels vidéos en français

## LIVE\_MOBILE

Conduct the show from your pocket

Live\_Mobile is available on iPhone and iPad via the AppStore and on Google Play for Android users.

- Try the latest version for free on our website !
- Download the latest updates, user guides and tutorials

[HTTP://WWW.SWEETLIGHT-CONTROLLER.COM](http://www.sweetlight-controller.com)



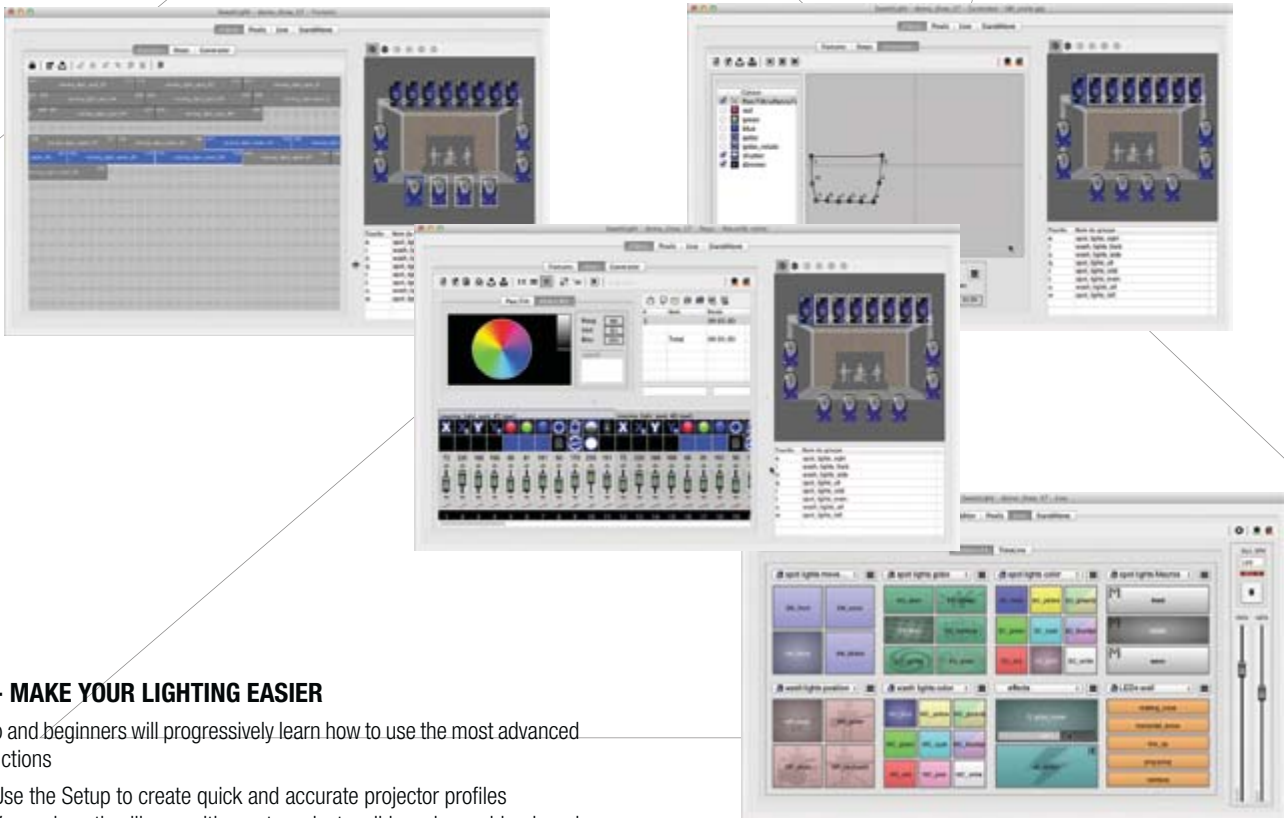

**1 - MAKE YOUR LIGHTING EASIER**

Pro and beginners will progressively learn how to use the most advanced functions

- Use the Setup to create quick and accurate projector profiles
- Very exhaustive library with most products, all brands combined, and the whole Contest DMX range of products
- Share your own creations on our forums
- Create scenes just like if you were using a lighting desk
- Create palettes and gain more time
- Many easy-handling tools (mouse-controlled Pan and Tilt, 1-click access to RGB colours, etc.)

**2 - SAVE TIME**

- Prepare, simulate and visualise with just a few clics
- Automatic patch creation, dipswitchs position for each projectors
- Create, organise and control projector groups
- Use the 3D simulator to prepare and visualise your shows
- Update your products without losing their current configuration
- Generator allows you to create complexe scenes in a few seconds
- Save your favourite sequences and copy them with a single clic
- Copy, cut, paste your scenes as much as you want

**3 - A LIVE BEAST**

Control your show

Sweetlight brings you the tools you need, should you be focused on the lights, the music, or far away from your show :

- A scene per button - adapt your pages to your needs
- Shorcut keys, bunding, DMX and MIDI control
- Standalone interfaces (Sweet-Remote, Sweet-Rack)
- Simple DMX stage creation, video, music and animated gifts
- 3D simulation of your created shows
- Very low system requirements
- New Sequential List function

**4 - BUILD YOUR COLOURS**

The LED projectors module

- Import your own building pictures or spaces you want to enlighten
- Place your projectors
- Create Chaser, Texte and Rainbow effects very easily



# SWEET RACK

The ultimate 19-inch SWEETLIGHT DMX interface

**Independent interface**

ref 10485

 Windows  
 macOS

MAC OS and Windows compatible



Sweet Light is available for download on [www.sweetlight-controller.com](http://www.sweetlight-controller.com)



The SWEETRACK is a standalone interface able to save up to 16 different chases or scenes.

Sweet Rack is easy to use via its 16 programs (configured via SweetLight beforehand) accessible via the front panel. Sweet Rack must be connected to our Sweetlight software to edit a program or scene and load it up into your device. Sweet Rack features 3 LED indicators: Power, USB link, DMX input

- + Can be rack-mounted
- + DMX Input
- + 512 DMX channels. Unlimited number of projectors
- + Simultaneous access to 3D and DMX modes
- + Compatible with PCs and Mac
- + Direct access to 16 scenes
- + Built-in, independent calendar to trigger scenes

# SWEET REMOTE

SWEETLIGHT DMX interface with 18 memories

**Installation and professional shows dedicated interface with built-in schedule**

ref 9635

 Windows  
 macOS

MAC OS and Windows compatible



- + 512 DMX channels
- + Connect as many projectors as you wish
- + IR repeater for SWEET-TELEC remote control
- + 18-scene memory access
- + Windows and Mac OS compatible
- + Built-in sequence launcher with schedule



# SWEET D512

SWEETLIGHT DMX interface with 1 memory

**Professional compact and independent interface**

ref 9634



MAC OS and Windows compatible



- + 512 DMX channels.
- + Connect as many projectors as you wish
- + Use simultaneously the DMX and 3D modes
- + Windows and Mac OS compatible

# SWEET-TELEC

Infrared remote control

**On-hand programs and functions**

ref 9819

- + Use with Sweet-Remote
- + 18-scene access
- + Speed control and reset



# SWEET CABLE

SWEETLIGHT DMX interface

**Start on the right foot with DMX**

ref 8287



- + Compact interface via USB key
- + Send instructions up to 10 different projectors and 100 DMX channels
- + Windows only

## TECHNICAL SPECIFICATIONS

- 18 launch keys to select your scene
- Speed-dedicated key allowing you to:
  - Decrease a scene speed
  - + Increase a scene speed
  - = Reset a scene speed

## TECHNICAL SPECIFICATIONS

This version cannot run the DMX and the 3D simulator simultaneously

Self-powered compact USB interface  
100 DMX channels and up to 20 simultaneous scenes

Controls up to 10 DMX projectors  
Access to DMX or 3D mode  
Windows compatible (more information on [www.contest-lighting.com](http://www.contest-lighting.com))  
Online help, demo version and the latest updates on : [www.sweetlight-controller.com](http://www.sweetlight-controller.com)

## TECHNICAL SPECIFICATIONS

|                         | CABLE   | D512                 | REMOTE               | RACK                 |
|-------------------------|---------|----------------------|----------------------|----------------------|
| <b>WITH A COMPUTER</b>  |         |                      |                      |                      |
| Operating system        | Windows | Win/Mac              | Win/Mac              | Win/Mac              |
| Communication           | USB     | USB                  | USB                  | USB                  |
| Nb Channels             | 100     | 512 dmx + 512 Artnet | 512 dmx + 512 Artnet | 512 dmx + 512 Artnet |
| Nb max interfaces       | 1       | 6                    | 6                    | 6                    |
| Dmx input               |         |                      |                      | ✓                    |
| DMX OPTICAL ISOLATION   |         |                      | ✓                    | ✓                    |
| <b>STAND-ALONE MODE</b> |         |                      |                      |                      |
| Nb dmx channels         | 0       | 512                  | 512                  | 512                  |
| Nb (dynamic) scenes     |         | 1                    | 18                   | 16                   |
| Nb zones                |         | 1                    | 4                    | 4                    |
| Nb flash buttons        |         |                      |                      | 16                   |
| IR remote controller    |         |                      | ✓                    |                      |
| Scheduler               |         |                      | ✓                    | ✓                    |
| External contacts       |         |                      | 4                    |                      |

# PILOT8

Le mixeur de couleurs\*

\*The colour shaker

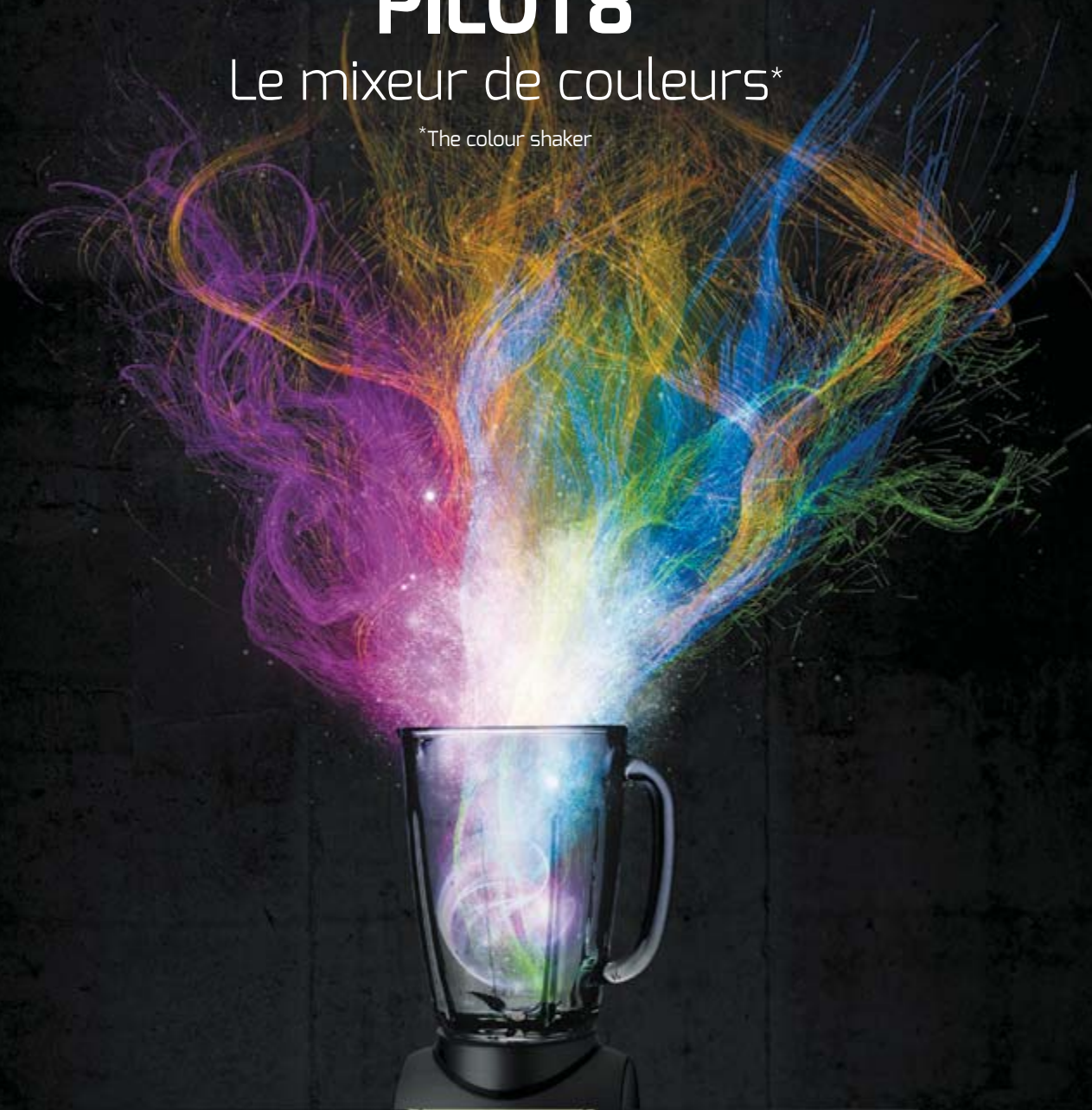

by **Contest**® 

# PILOT-8

8x8 programmable channels controller

**Control your colours**

ref 10126

Start on the right foot with the PILOT-8 controller. It is easy to access and offers a lot of possibilities. It was designed for LEDs projectors, has 8 group-adaptable channels so you can easily mix different models.

- + 8 channels for each projector groups
- + Assignable patch and modulable channels
- + Quick access to colours and programs



### A DIRECT ACCESS TO YOUR PROJECTORS

The PILOT-8 controls up to 8 projector groups. Each projector is assigned to a key, allowing you to switch and group in one step. You can assign different colours to different projectors and easily create complex light effects.

### QUICK ACCESS TO COLOURS

8 built-in colours and 6 customizable colours are accessible. The PILOT-8 controller make your colour changes simple with a user-friendly interface.

### USE YOUR OWN PROGRAMS

The PILOT-8 allows you to create 8 user programs and change the colours to meet your every need. Adjustable speed, slow transition and music-sensitive mode, the PILOT-8 offers open-handed possibilities.

### FULL CONNECTORS

The Pilot-8 standard DMX signal is available in 3 formats: classic XLR3, 5-pin XLR and RJ45.

### TECHNICAL SPECIFICATIONS

|  |  |
|--|--|
| Number of channels : 64                      | Adjustable sequence speed  |
| Independent projectors : 8                   | Connectors :   |
| Max channels per projector : 8               | - XLR via a DMX output   |
| Built-in colours : 8                         | - RJ45 to control via DMX the Contest Architecture series PILOT products                         |
| User colours : 24                            | - External Easy-2 controller on jack input allowing programs launch, colour select and black out |
| User programs : 8 programs of 32 steps each  | USB-powered nightlight supplied  |
| RGBWA and dimming functions assignable patch | Measurements : 400 x 200 x 68 mm   |
| 2 additional assignable channels             | Weight : 2.3kg   |
| Strobe function                              |  |



# MEMORY-24

DMX intelligent lighting controller

**The much-needed lighting desk**

ref 9067

176

- + Internal timing, manual and sound-sensitive modes
- + Double Master A/B function
- + Live and direct access to scenes



## TECHNICAL SPECIFICATIONS

|   |   |
|---|---|
| 24-control slides preset board with memory                        | Manually launch sets via the Tap Sync key         |
| 2x12-control slides fader banks or 1x24 control slides fader bank | MIDI scenes and sets launching                    |
| Flash on every control slide                                      | DMX 512 output via 3-pin XLR3 cable               |
| Up to 4600 steps, 48 programmable sets                            | External power supply (9 V - 12 V, 500 mA, DC)    |
| Fade out  | Supplied with an amovable black protective casing |
| Live or offline building and scene modifications                  | Supplied with 1 external power supply             |
| Adjustable sequences speed and rise time                          | Materials : Steel case                            |
| Every step is saved in the built-in memory                        | Measurements : 483 x 265 x 90 mm / rack 19"       |
| Mix several sets  | Weight : 4.6 kg                                   |
| Music detection via the built-in microphone or an external source |   |



# PILOT-192PRO

DMX intelligent lighting controller

**The essential intelligent lighting console**

ref 9073

- + 192 channels (12 projectors with 16 channels each)
- + Joystick
- + Can memorize a large number of scenes
- + Manual, on tap and sound-sensitive speeds



Pan and Tilt assignable joystick for each projector

Pilot up to 192 channels.  
30x8-program groups available.



## TECHNICAL SPECIFICATIONS

192 channels (12 projectors x 16 channels)

30x8-program banks

12 chasers (240 steps per chaser)

Pan/Tilt Fade Time

MIDI memories and blackout settings

Assignable joystick to pilot the Pan/Tilt projector movements

Foot control output

Data emission/reception via a RS232 socket

Music detection via the built-in microphone or an external source

Measurements : 483 x 82 x 135 mm

Weight : 2.2 kg

# MANU-6X

DMX command panel  
**6 universal channels**  
 ref 9064

- + 6-channel DMX command panel
- + 6 faders + Master
- + Can be operated with a battery



178

## TECHNICAL SPECIFICATIONS

- 6-channel DMX command panel
- 6 faders + Master
- Can be operated with a 9V battery
- AC adaptor supplied
- Perfect for architectural colour changer lightings
- DMX output: 3-pin XLR
- Dimensions : 173 x 153 x 55 mm
- Weight : 0.8 kg

# PARPILOT

DMX command panel  
**Colour and program management. Up to 4 projectors simultaneously**  
 ref 9658

- + Direct access to colours and elaborate scenes
- + Adjustable scene speed
- + Manual, auto and music-sensitive modes



# EASY-2

Command panel  
**Simplified universal remote control compatible with a large number of CONTEST® products\***  
 ref 8701

- + Black-out
- + Colour selection
- + Adjust the program speed



## TECHNICAL SPECIFICATIONS

- 2-control modes : Fixed colours and sequences
- 4 or 16 DMX channels
- 10 built-in programs
- Music-sensitive + Tap Tempo modes and colour variations
- Fast access to the 8 fixed colours
- Adjustable speed and intensity
- Strobe effect: 16 flashes per second
- Fast or progressive colour sequencing
- Black out
- Power supply : 12 V 100 mA, DC (supplied)
- Dimensions : 70 x 110 x 33 mm
- Weight : 0.31 kg
- Compatible with the LED4 STAGE and the Contest® LED PAR products

## TECHNICAL SPECIFICATIONS

- Connectors : Jack 6.35 stéréo
- Cable length : 11 m

\* Compatible with :  
 LED-BLASTER, LED-OMEGA, LED-SPIDER, LED-STAR, LED-SUPRA, LED-GUN,  
 SCN830, NINO, LE CLUB series

# PARCONTROL34

Customer-designed DMX controller for RGB/RGBW compatible products

**Simply take control**

ref 9913

**COMPATIBILITY**

**MODE 1 : RED GREEN BLUE DIMMER/STROBE WHITE**

For the following products: LED-64, LED-56, LED-38, LED-36, iLED series, irLED series, irLEDFLAT-QC, POWTAPE, POW50R, POW100R, IPLINE18TC, LED4STAGE, PILOT60, PILOT120, PILOT240...

**MODE 2 : RED GREEN BLUE WHITE**

For the following products: iLED series, irLED series, irLEDFLAT-QC, PILOT60, PILOT120, PILOT240, séries IPBLIND, IP-SPOT108, IPLINE18TC, COLOR12TC...

**TECHNICAL SPECIFICATIONS**

- ..... Only for RGB, tricolour and quadricolour products\*
- ..... 2 Modes
- ..... Direct access to 30 colours (15 RGB, 15 RGBW\*)
- ..... Direct access to built-in programs
- ..... Adjustable speed and intensity
- ..... Control the strobe as it pleases you
- ..... Accurate colour management
- ..... The music-sensitive mode uses the built-in microphone
- ..... Power supply : 9-12V 300 mA, DC
- ..... Power consumption : 3.6 W
- ..... Dimensions : 270 x 170 x 60 mm
- ..... Weight : 1.1 Kg



- + Easy to use
- + Direct access to more than 30 colours and programs\*
- + Total brightness and strobe controle
- + The music-sensitive mode uses the built-in microphone

\* Only the compatible projectors can access the RGBW colours and programs

# PARCONTROL

DMX command panel

**The PARCONTROL is easy to use, and will quickly become your RGB LED projectors' new best friend thanks to its fast accesses to many colours and functions**

ref 9406

**TECHNICAL SPECIFICATIONS**

- ..... 4 pre-programmed DMX modes
- ..... 9 pre-programmed colours
- ..... RGB colour gradients
- ..... Built-in programs with adjustable speed
- ..... Adjustable flash speed
- ..... Auto or music-sensitive modes
- ..... Black-out
- ..... Power supply : 9-12 V 300 mA, DC
- ..... Power consumption : 3.6 W
- ..... Dimensions : 220 x 140 x 36 mm
- ..... Weight : 1 kg



- + Direct access to 9 colours and many programs
- + Red, Green and Blue colour gradients
- + Compatible with the Contest® LED PARs, irLEDs, TRI4U, IPSPOT...

# airBOX-ER1V1.3

DMX wireless receiver/transmitter airBox-ER1

ref 9966

The airBOX-ER1 allow you to transmit or receive the airDMX signal. As soon as it detects an incoming DMX wired signal the airBOX-ER1 automatically transmits it as a Wi-Fi DMX signal. The removable attachment system allows you to easily install the airBOX-ER1 on a wall or on any suitable structure. The power socket can be used to link the airBOX-ER1 to other DMX projectors, or with both DMX and power connections.



180

More information about the airDMX network pages 86 and 87 or on [www.contest-lighting.com](http://www.contest-lighting.com)

## SPLIT SERIES

DMX line splitter

**EASILY CONNECT MANY LINES TO A SINGLE SOURCE WITH THESE DMX LINE SPLITTERS.**

### TECHNICAL SPECIFICATIONS

|  |
|--|
| Optoelectronic isolator input/output                 |
| 3-pin and 5-pin-XLR input/output                     |
| Power supply : 230 V - 50 Hz / 120 V - 60 Hz         |
| Fuse-protected against overvoltages : 500 mA - 250 V |

- + Interference isolator
- + Signal booster
- + Less cables

# SPLIT-2

ref 7546

1 input / 2 outputs line splitter  
 Dimensions : 245 x 165 x 72 mm  
 Weight : 1.9 kg



# SPLIT-4

ref 7547

1 input / 4 outputs line splitter  
 LED signal indicator for each channel - Link output  
 Dimensions : 280 x 170 x 75 mm  
 Weight : 2.7 kg





# BREAK-3X16

Power pack

**Three-phase power divider with voltage and amperage display**

ref 9059

- + Bipolar circuit-breaker
- + Voltage and Amperage display
- + 6x16A French output sockets



181

## TECHNICAL SPECIFICATIONS

Three-phase 6x16A converter

Input : 1 5-pin CEE

Output : 6 x 16 A compatible NF sockets

Each circuit is protected by a bipolar circuit-breaker

Each phase has its own Voltmeter and Ammeter

1 output socket with lid

Sheet steel casing and metal front plate

Rack mounting: 19"/2 U

Weight : 3.8 kg

# BREAK-3X32

Power block

**Power divider protecting your installations**

ref 9070

- + Each output has its own bipolar circuit-breaker
- + 30mA Differential circuit-breaker
- + Each phase has its own Volt and Ampere display

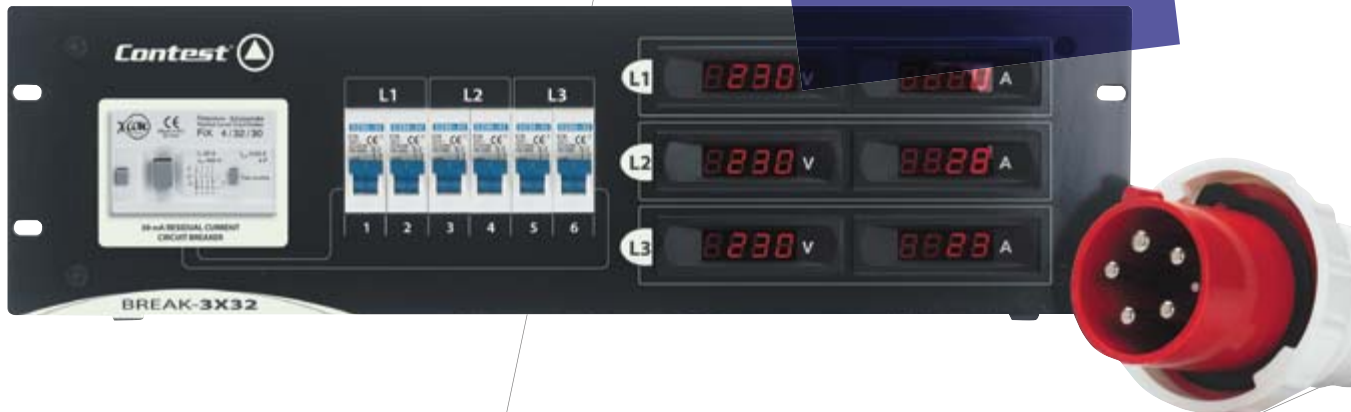

## TECHNICAL SPECIFICATIONS

Three-phase 6x16A converter

Input : 1x5-pin 3 x 32 A CEE

Output : 6 x 16 A compatible with french plugs and 1x5-pin 3 x 32 A CEE

Each plug is protected by a bipolar circuit-breaker

Manual power override and 30 mA differential circuit-breaker

Each phase has its own Voltmeter and Ammeter

Sheet steel casing and metal front plate

Supplied with a power cord and a 5-pin CEE male plug

Rack mounting: 19"/3 U

Depth (including the 32 A output) : 260 mm

Weight : 7 kg

# DIM-1x10

Power pack

**Compact power pack 1 x10 A plug with fader**

ref 9061

182

- + Supplied with an external fader
- + Dimmer or Switch modes
- + DMX input/output via XLR plug and power output via french plug

## TECHNICAL SPECIFICATIONS

- Standard DMX 512, internal/external fader supplied
- Dimmer functions for theatre projectors
- Mode interrupteur pour les appareils motorisés ou ventilés
- DMX addressing via a large LCD screen
- DMX input/output via 3-pin XLR
- Lid-protected french plug outputs
- Fixation brackets
- Power supply : AC 230 V, 50/60 Hz
- Dimensions : 150 x 125 x 82 mm
- Weight : 1.5 kg



# DIM-4x5

Power pack

**4-way DMX and analogic 4x5 A compact bloc with faders**

ref 9057

- + Built-in programs with adjustable speed
- + Built-in manual dimmer
- + DMX input/output via XLR plug and power output via french plug

## TECHNICAL SPECIFICATIONS

- 16 chase built-in programs with adjustable speed
- Fader individuel par voie, avec réglage de la vitesse d'exécution
- 4 DMX 512 independent channels
- Modes : Master/slave, program, DMX, sound-sensitive via microphone
- Switch/dimmer pack
- Control 4 DMX channels with the faders
- Outputs : 4 x 5 A (16 A max) via french power plugs
- Power supply : 120 V / 230 V - 50/60 Hz, AC 16 A maximum
- Dimensions : 250 x 208 x 68 mm
- Weight : 2.5 kg



# DIM-6x16

Power block

**6 x 16 A Power control unit with built-in, DMX or manually controllable dimmer**

ref 9058

- + 6-channel dimmer
- + Each channel is protected by a bipolar circuit-breaker
- + DMX Input/output via a XLR connector, power output via the terminal



183

## TECHNICAL SPECIFICATIONS

ON/OFF LEDs assigned to each plug

0-50% adjustable pre-heating via the potentiometer

DMX addressing dip switch

6 linear potentiometers allowing a manual gradation

Power indicator LEDs for each channel

Power supply : single-phase or three-phase power supply via internal terminal block (230 V - 50 Hz)

Power output : 16 A (3 500 W) per channel; 96 A max. resistive/inductive

Rear outputs

DMX input/output via 3-pin XLR plug

Each channel is protected by a bipolar circuit-breaker

Dimensions : 482 x 390 x 90 mm / 19" rack mountable

Weight : 7 kg

# DP8

Power control unit

**The switchboard is a vital tool for any installation**

ref 9407

- + Power output via French sockets at the rear
- + Each switch has its own indicator light showing if the channel is busy or not, ON or OFF
- + Each channel has its own fuse protection



## TECHNICAL SPECIFICATIONS

8-way line splitter with bipolar switches

Power outputs: 8 french plugs

A light indicator shows you when a channel is powered up

15 A fuse (the max current cannot exceed 15 A)

19" mounting rack

Power supply : 230 V - 50 Hz

Power supply cable length : 1.30 m

Dimensions : 483 x 87 x 83 mm





*Conteststage*



# STAGE PLATFORM

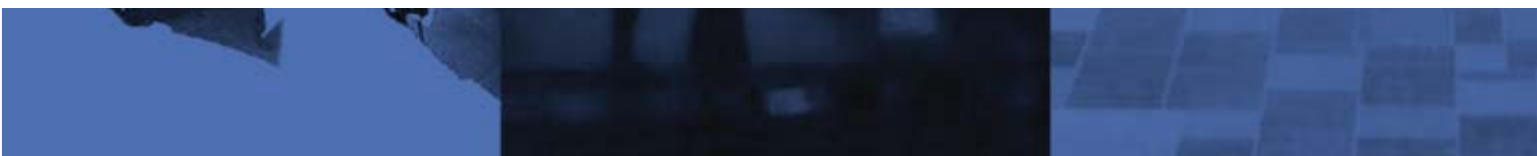



## QUICK AND EASY INSTALLATION

CONTEST STAGE structures were designed to be quick and easy to set up. They do not require any specific qualifications and can be installed without supervision of a technician.



### SAFETY AND QUALITY

Quality is one of our key values. we only use high-quality materials and cutting-edge technologies, with the utmost respect for norms and regulations. This is why our products have many certifications such as ISO, DIN and TÜV.

### THREE TIMES SAFER

The CONTEST STAGE aluminium trusses are GSI SLV and TÜV certified.



GSI SLV Hannover is a world-recognized institute specialising in certifications in line with European strict standards. Our production line has a certificate delivered by GSI SLV Hannover and certifying that we master every welding method mentioned by the DIN EN ISO 3834-3, DIN 4113 and DIN 18800-7 norms. This is why our products are among the best of Europe in terms of quality and safety.

TÜV NORD is a world-recognized international certification body. The TÜV NORD certificates are a guarantee for consistent and safe products. An annual TÜV inspection takes place to ensure our products adapt to new norms and reforms. TÜV Bauart certificates are delivered for very specific products, based on several analysis and structural testing.



CONTEST STAGE received a complete, validated set of certificates guaranteeing our production factory know-how and the safety of our aluminium trusses, also available on our website.

Aluminium structures require structural analyses and static calculations, especially when exposed to weather and wind. We cooperate with the best professionals of the industry in this regard, including the German laboratory "EXPO Engineering", leader in its field.



We are designing and supplying platforms based on calculations compliant with "DIN" norms. That means we take every information about load capacity, ballasts, etc. into account.

We want to make sure our clients know our products are safe and compliant with norms required by specific countries.

# PLATFORMS

## STAGE SERIES



### PLTS-2x1

2 x 1 m non-slip platform  
ref 10369

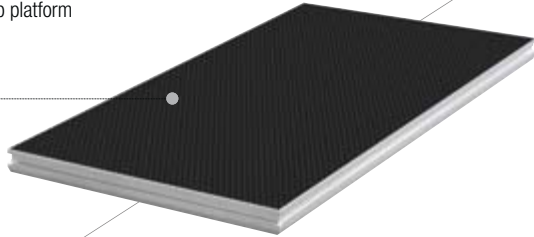

Feet not supplied

Non-slip black plywood 12 mm



### PLTS-2x1

2 x 1 m non-slip platform  
ref 10601



Feet not supplied

### PLTS-1x1

1 x 1 m non-slip platform  
ref 10370

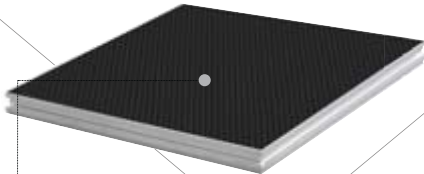

Feet not supplied

### PLTS-1x0,5

1x0,5 m non-slip platform  
ref 10602



Feet not supplied

### PLTS-T1x1

1x1 m triangular non-slip platform  
ref 10603



Feet not supplied



Non-slip black plywood 12 mm

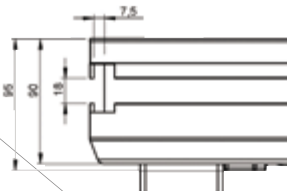
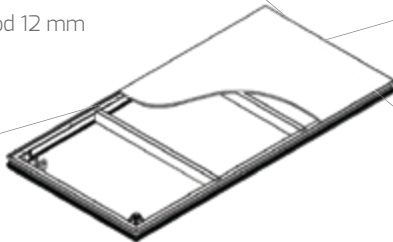

Plywood internal structure of the platform and aluminium chassis (EN AW6082T6)

| SPECIFICATIONS | PLTS-2x1                | PLTS-2x0,5 | PLTS-1x1 | PLTS-1x0,5 | PLTS-T1x1 |
|----------------|-------------------------|------------|----------|------------|-----------|
| Size           | 2x1 m                   | 1x0,5 m    | 1x1 m    | 1x0,5 m    | 1x1 m     |
| Load Capacity  | 750 kg/m <sup>2</sup> * |            |          |            |           |
| Deck           | 12 mm                   |            |          |            |           |
| Profile Height | 90 mm                   |            |          |            |           |
| Weight         | 29 kg                   | 16 kg      | 20,7 kg  | 12,6 kg    | 12 kg     |

\* 750 kg/m<sup>2</sup> spread over the whole platform with square feet (Height: 150cm max)

#### FIRE RESISTANCE

Fire resistance class: Bfl-S1  
Compliant with the EN13501-1+A1:2010  
European norm.



**SAMPLES SETUPS**

**SAMPLE SETUPS INCLUDING 4 PLTS-2X1**

NOTE: We recommend using the 2-feet (PLTS-fc2) and 4-feet (PLTS-fc4) connection clips to guarantee the stability of high structures (1m and above).

**CAUTION IN COMPLIANCE WITH NF E85-015**

The maximum height allowed is 150cm.

A guardrail must be installed for platforms higher than 50cm.

These provisions are not comprehensive.

Please get a copy of the aforementioned norm for more information.

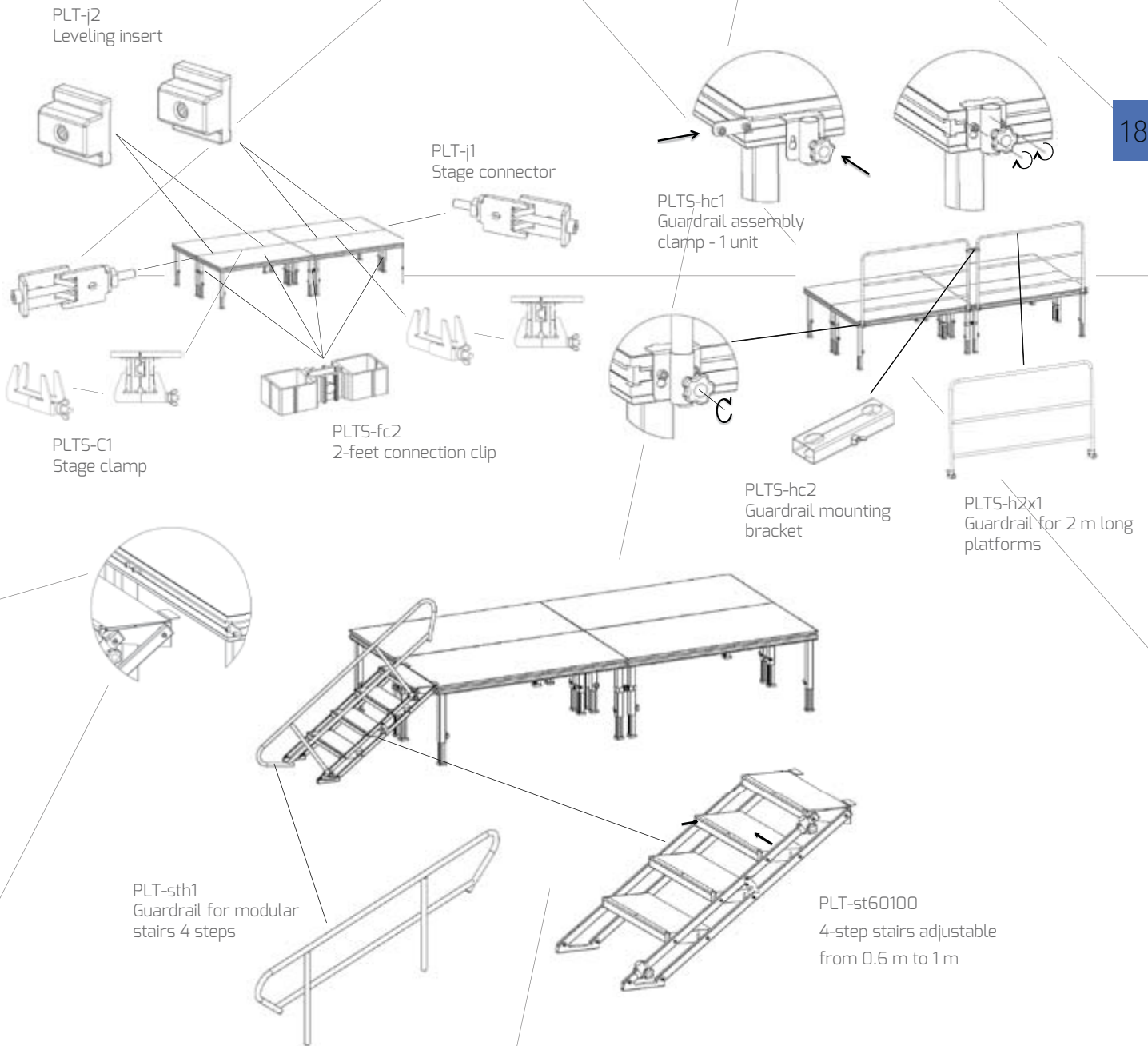

**ABOUT SOIL'S CAPACITY**

Soft soils can affect the safety of your installation.

Please distribute the weight of the load uniformly.

**ABOUT GUARDRAILS & STAIRS**

A guardrail must be installed for platforms higher than 50cm.

Stairs with a width less than or equal to 120cm must be equipped with at least one handrail.

# PLATFORM STANDS & ACCESSORIES

188

## PLTS-ft4060

Telescopic square aluminium foot from 40 cm to 60 cm  
1 unit  
ref 10374

## PLTS-ft60100

Telescopic square aluminium foot from 60 cm to 1 m  
1 unit  
ref 10375

## PLTS-ft80140

Telescopic square aluminium foot from 80 cm to 1.40 m  
1 unit  
ref 10403



## PLTS-f20

Square aluminium foot 20 cm - 1 unit  
ref 10376

## PLTS-f40

Square aluminium foot 40 cm - 1 unit  
ref 10377

## PLTS-f60

Square aluminium foot 60 cm - 1 unit  
ref 10378

## PLTS-f80

Square aluminium foot 80 cm - 1 unit  
ref 10379

## PLTS-f100

4 Square aluminium foot 100 cm - 1 unit  
ref 10380

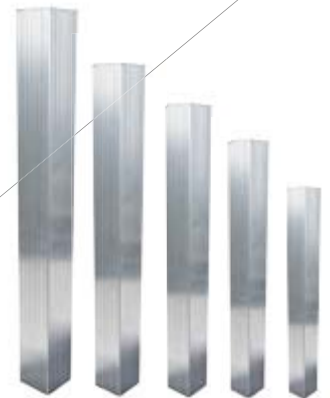

## AVAILABLES ACCESORIES



### PLTS-cl

Stage clamp  
ref 10371



### PLTS-fc2

2-feet connection clip  
ref 10381



### PLTS-fc4

4-feet connection clip  
ref 10382



### PLT-j1

Stage connector  
ref 10372



### PLT-j2

Leveling insert  
ref 10373



### PLTS-h2x1

Guardrail for 2 m platform  
ref 10391



### PLTS-h1x1

Guardrail for 1 m platform  
ref 10392



### PLTS-hc1

Guardrail assembly clamp - 1 unit  
ref 10393



### PLTS-hc2

Guardrail mounting bracket  
ref 10394



### PLTS-g1x1

Guardrail - 1 m - no accessory  
ref 10421

Accessories supplied

Accessories supplied



### PLTS-g2x1

Guardrail - 2 m - no accessory  
ref 10421



### PLTS-gc1

Guardrail connector  
ref 10454



### PLTS-gc2

Guardrail angle connector  
ref 10455



### PLT-BOARD

Platform caster board  
ref 10423



### PLT-TROLL

Platform trolley  
ref 10424





# PLATFORM LIGHT SERIES



## PLTL-1x1

1 x 1 m non-slip mobile platform

ref 10395



190

### SPECIFICATIONS

| SPECIFICATIONS | PLTL-1x1                 |
|----------------|--------------------------|
| Color          | Black                    |
| Size           | 1x1 m                    |
| Load Capacity  | 500 kg/m <sup>2</sup> *  |
| Height         | 55 mm                    |
| Frame          | Aluminium (EN AW-6063T6) |
| Weight         | 12,1 kg                  |

\* 500 kg/m<sup>2</sup> spread over the whole platform with square feet (Height: 60cm max)

### FIRE RESISTANCE

Fire resistance class:  
Bfl-S1 Compliant with the  
EN13501-1+A1:2010 European norm.



Non-slip black plywood 12 mm

## PLTL-f20

Risers for 1x1m mobile platform height 20 cm

ref 10396

## PLTL-f40

Risers for 1x1m mobile platform height 40 cm

ref 10397

## PLTL-f60

Risers for 1x1m mobile platform height 60 cm

ref 10398

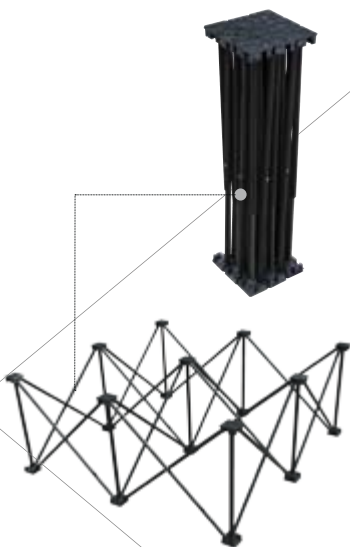

### CAUTION

Two supports can be combined, however their height must not exceed 1 meter.

## AVAILABLES ACCESORIES



### PLTL-hc1

Guardrail mounting bracket for mobile platform  
ref 10400



### PLTL-CLIP

Clip for PLTL (to be combined with PLTL-CON)  
ref 10604



### PLTL-CON

Joint connector for series platform supports (to be combined with PLTL-CLIP)  
ref 10605



### PLTL-h1x1

Guardrail for 1m PLTL platform  
ref 10399



### PLT-BOARD

Platform caster board  
ref 10423



### FLY6PLTL1

Flight-case designed for 6 PLTL-1x1 with risers  
ref 10430

| SPECIFICATIONS  | PLTL-f20 | PLTL-f40 | PLTL-f60 |
|-----------------|----------|----------|----------|
| Color           |          | Black    |          |
| Height (folded) | 464 mm   | 574 mm   | 726 mm   |
| Width (folded)  |          | 153 mm   |          |
| Weight          | 2,6 kg   | 3,5 kg   | 4,5 kg   |

### ABOUT GUARDRAILS

A guardrail must be installed for platforms higher than 50cm.





# STAGE SKIRTS



|              |                |   |
|--------------|----------------|---|
| <b>10469</b> | PLTL-JU20x100  | Stage skirt for PLTL platform H20cm L105cm        |
| <b>10470</b> | PLTL-JU40x100  | Stage skirt for PLTL platform H40cm L105cm        |
| <b>10471</b> | PLTL-JU60x100  | Stage skirt for PLTL platform H60cm L105cm        |
| <b>10472</b> | PLTL-JU80x100  | Stage skirt for PLTL platform PLTL H80cm L105cm   |
| <b>10473</b> | PLTL-JU100x100 | Stage skirt for PLTL platform PLTL H100cm L105cm  |
| <b>10474</b> | PLTL-JU20x200  | Stage skirt for PLTL platform PLTL H20cm L205cm   |
| <b>10475</b> | PLTL-JU40x200  | Stage skirt for PLTL platform PLTL H40cm L205cm   |
| <b>10476</b> | PLTL-JU60x200  | Stage skirt for PLTL platform PLTL H60cm L205cm   |
| <b>10477</b> | PLTL-JU80x200  | Stage skirt for PLTL platform PLTL H80cm L205cm   |
| <b>10478</b> | PLTL-JU100x200 | Stage skirt for PLTL platform PLTL H100cm L205cm  |
| <b>10479</b> | PLTL-JUSUP     | Fastening profile for stage skirts PLTL-JU L105cm |

191

## SAMPLE SETUPS

20m<sup>2</sup> sample setups including PLTL-1x1 platforms, connected via PLT-j2 leveling inserts and PLT-j1 stage connectors.



### CAUTION IN COMPLIANCE WITH NF E85-015

The maximum height allowed is 100cm.

A guardrail must be installed for platforms higher than 50cm.

These provisions are not comprehensive.

Please get a copy of the aforementioned norm for more information.

### ABOUT SOIL'S CAPACITY

Light series platform must be set up over perfectly flat areas.

Each plastic support must be in direct, firm contact with the ground. As a result, this platform cannot be used on soft or uneven soils.

### ABOUT GUARDRAILS & STAIRS

A guardrail must be installed for platforms higher than 50cm.

Stairs with a width less than or equal to 120cm must be equipped with at least one handrail.

# STAIRS

## STAGE & LIGHT SERIES



### PLT-st4060

2-step stairs Adjustable height from 0.4 m to 0.6 m  
ref 10383

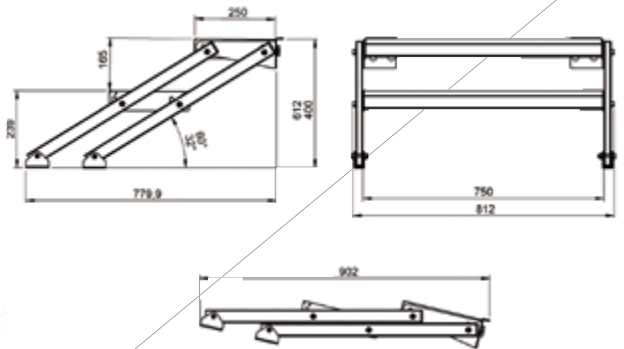

#### ATTENTION

In order to guarantee your own safety, the current regulations require a 2-meter long platform (minimum) when using adjustable stairs in order to prevent the platform from tilting.

### PLT-st60100

4-step stairs adjustable height from 0.6m to 1m  
ref 10384

### PLT-st80140

5-step stairs adjustable height from 0.8m to 1.4m  
ref 10404

**NEW**

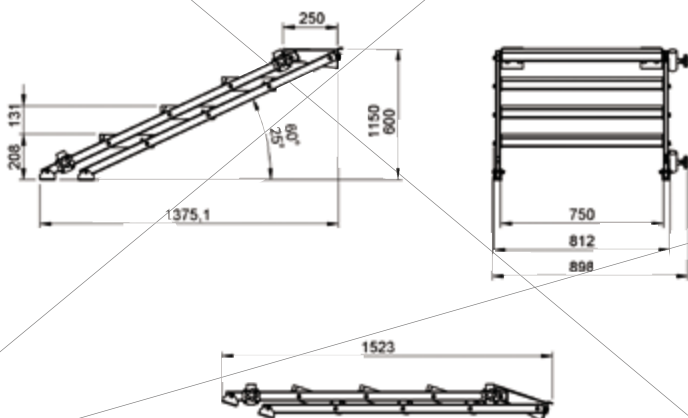

### AVAILABLE ACCESSORY

#### PLT-sth1

Handrail for 4-step adjustable stairs  
Length: 2285 mm  
Max. height: 750 mm  
ref 10385

**NEW**



| SPECIFICATIONS  | PLT-st4060                   | PLT-st60100 |
|-----------------|------------------------------|-------------|
| Height          | 40 - 60 cm                   | 60 - 100 cm |
| Number of steps | 2                            | 4           |
| Material        | Steel                        |             |
| Steps material  | Non-slip black plywood 12 mm |             |
| Width           | 750 mm                       |             |
| Weight          | 16,5 kg                      | 30 kg       |

#### CAUTION

Stairs with a width less than or equal to 120cm must be equipped with at least one handrail.



**PLT-stm20**

1-step stairs - Height 20 cm  
ref 10386

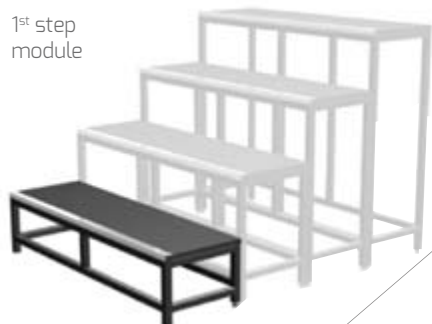

1<sup>st</sup> step module

**PLT-stm40**

2-step stairs - Height 20 cm and 40 cm  
ref 10387

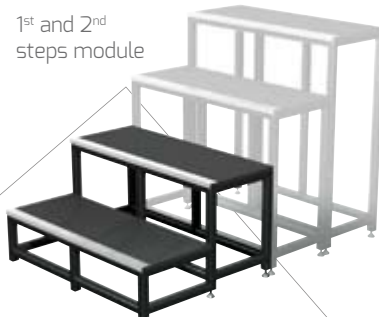

1<sup>st</sup> and 2<sup>nd</sup> steps module

**PLT-stm60**

3<sup>rd</sup> step - Height 60 cm  
ref 10388



3<sup>rd</sup> step module

**PLT-stm80**

4<sup>th</sup> step - Height 80 cm  
ref 10389



4<sup>th</sup> step module

**CONFIGURATION:**

You will require the 3 following modules to assemble 4-step stairs:

- PLT-stm40
- PLT-stm60
- PLT-stm80

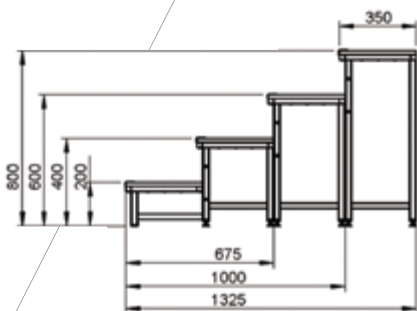

**AVAILABLE ACCESSORY**

**PLT-sth2**

Handrail for 3 and 4-step adjustable stairs  
Length: 140 cm  
ref 10390



| SPECIFICATIONS           | PLT-stm20                    | PLT-stm40 | PLT-stm60 | PLT-stm80 |
|--------------------------|------------------------------|-----------|-----------|-----------|
| Height                   | 20                           | 40        | 60        | 80        |
| Number of steps per unit | 1                            | 2         | 1         | 1         |
| Material                 | Steel                        |           |           |           |
| Steps material           | Non-slip black plywood 12 mm |           |           |           |
| Feet regulation          | 2 cm                         |           |           |           |
| Weight                   | 10,6 kg                      | 22 kg     | 13,6      | 14,8      |

**CAUTION**

Stairs with a width equal to or above 120cm must be equipped with two handrails.

# GAMME PASSAGE DE CÂBLES

Une robustesse monumentale\*

\*Incredibly strong



by **Contest**<sup>®</sup>



- + Flame-retardant
- + Super strong
- + Easy to install

# CABLE PROTECTORS

Our Contest® cable protectors series was designed to preserve cables during shows. They are made of polyurethane to resist heavy loads while remaining anti-fire. They are fully adaptable to any surface.

They are as easy-to-use as space-saving and can be used intensively or temporarily. Finally, their hoods have been designed not to open unexpectedly in order to keep your cables protected at all time.

## XC5-64

Flexible cable protector  
**5 conduits 64 mm length 9 m**  
 ref 10734

**NEW**



## XC5-121

Flexible cable protector  
**5 conduits 121 mm length 9 m**  
 ref 10735

**NEW**

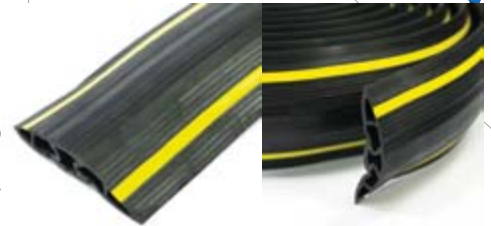

195

## XC233

Cable protector  
**Cable protector with 2 x 3x3cm conduits + hood Length 1m**  
 ref 10426

## XC14

Cable protector  
**1x4 cm, Length: 1m**  
 ref 10425

## XC233AG

45° Angle for XC233 cable protector  
 ref 10427

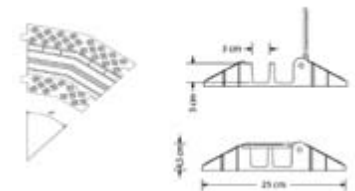
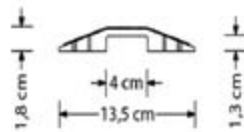
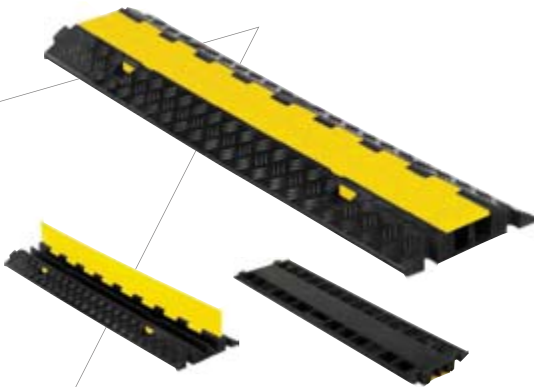

| INFORMATIONS TECHNIQUES | XC14                           | XC233   | XC233AG | XC5-64   | XC5-121  |
|-------------------------|--------------------------------|---|---------|--|--|
| Material                | Polyurethane                   | Rubber + polyurethane (base)<br>polyurethane + PVC (hood) |         | Injection molded 80% Virgin<br>PVC and 20% NBR | Injection molded 80% Virgin PVC<br>and 20% NBR |
| Fire resistance         |                                | Classe B1   |         | Classe B1                                      | Classe B1                                      |
| Electrical safety       | Directive 73/23/CE             |   |         |  |  |
| Conduit                 | 1                              | 2   |         | 5  | 5  |
| Conduit dimension       | 38 mm x 13 mm                  | 30 mm   |         | 14 x 9,7 mm                                    | 16,7 X 15 mm                                   |
| Static load             | 100 kg over a 20x20<br>cm area | 2500 kg over a 20x20 cm area                              |         | 200 kg   | 200 kg   |
| Width                   | 135 mm                         | 250 mm  |         | 64 mm  | 121 mm   |
| Lenght                  | 1000 mm                        | 1000 mm   | 285 mm  | 9 mm   | 9 mm   |
| Height                  | 35 mm                          | 15 mm   | 45 mm   | 12 mm  | 23 mm  |
| Weight                  | 2 kg                           | 7,9 kg  | 3 kg    | 7,5 kg   | 16,5 kg  |





*Contestage*



## AN EXTENSIVE RANGE

The CONTEST STAGE series offers a wide range of products to organize small and large scale events. All the CONTEST STAGE products are designed and fabricated in Europe according to a very strict philosophy emphasizing on simplicity, normalisation, ease of use and flexibility to ensure an absolute safety.

## SAFETY AND QUALITY

Quality is one of our key values. We only use high-quality materials and cutting-edge technologies, with the utmost respect for norms and regulations. This is why our products have many certifications such as ISO, DIN and TÜV.

## TWICE SAFER



The CONTEST STAGE aluminium trusses are GSI SLV and TÜV certified.

GSI SLV Hannover is a world-recognized institute specialising in certifications in line with European strict standards. Our production line has a certificate delivered by GSI SLV Hannover and certifying that we master every welding method mentioned by the DIN EN ISO 3834-3, DIN 4113 et DIN 18800-7 norms. This is why our products are among the best of Europe in terms of quality and safety.



TÜV NORD is a world-recognized international certification body. The TÜV NORD certificates are a guarantee for consistent and safe products. An annual TÜV inspection takes place to ensure our products adapt to new norms and reforms. TÜV Bauart certificates are delivered for very specific products, based on several analysis and structural testing.

CONTEST STAGE received a complete, validated set of certificates guaranteeing our production factory know-how and the safety of our aluminium trusses, also available on our website.

## DO IT BY THE BOOK

Load tables indicate the maximum load-bearing capacity between two fixation points. However, there are many mounting methods, making impossible to really know the load capacity of your installation. We strongly advise you to ask for the help of a qualified technician.

# CONTESTAGE PROFESSIONAL TRUSSING

# QUATRO29

Aluminium square truss

ISO DIN 4113 and TÜV certified.

Made of 50mm aluminium alloy (EN AW 6082 T6, diameter 50 mm, thickness 2 mm) .

Square structure allowing heavier loads, with conical connectors.

- Width 290 mm.
- Tube diameter: 50 mm, thread: 16 mm.

This structure is supplied with :

- 1 x connection kit per truss
- 1 x connection kit per 2-direction angle
- 2 x connection kit per 3, 4 and 5-direction angle



198

Illuminate your square truss with

**MINITRUSS-6TCb**

See page 90 - ref 10365



**QUA29-029**

ref 10118

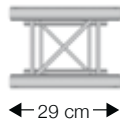

**QUA29-050**

ref 10049

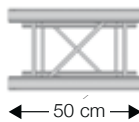

**QUA29-071**

ref 10593

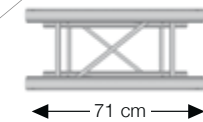

**QUA29-100**

ref 10050

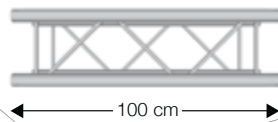

**QUA29-200**



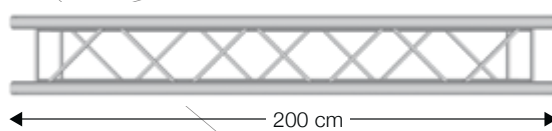

ref 10051

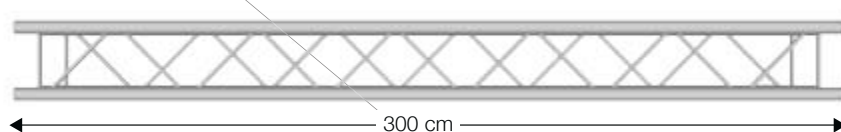

**QUA29-300**

ref 10052



| LENGTH (M)                  |  | 4    | 6    | 8    | 10   | 12    | 14    | 16    |
|-----------------------------|---|------|------|------|------|-------|-------|-------|
| Max load (center) (kg)      |  | 1167 | 769  | 568  | 445  | 361   | 299   | 252   |
| Distortion (mm)             |  | 12,5 | 28,2 | 50,3 | 79,1 | 114,5 | 157,0 | 206,8 |
| Max distributed load (kg/m) |  | 449  | 256  | 142  | 89   | 60    | 43    | 32    |
| Distortion (mm)             |  | 12   | 35,1 | 62,4 | 97,5 | 140,3 | 191,0 | 249,5 |

Load tables indicate the maximum load-bearing capacity between two fixation points. Centered and distributed loads cannot be cumulated. Talk to a qualified engineer for more information.



**ANGLE CONNECTION KITS**

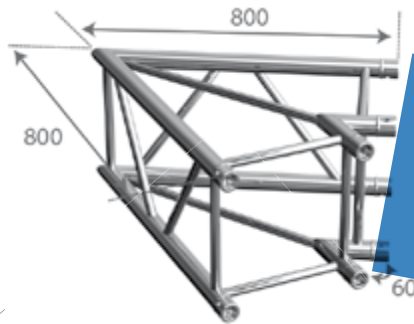

- + Quatro angle
- + 2 directions
- + 80 cm 60°

AGQUA-01

ref 10053

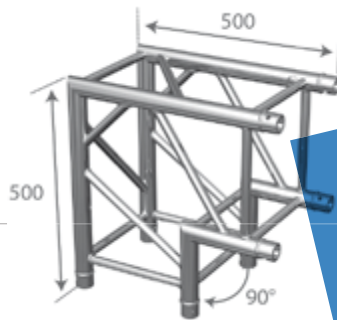
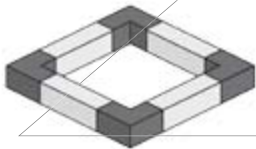

- + Quatro angle
- + 2 directions
- + 50 cm 90°

AGQUA-02

ref 10054

199

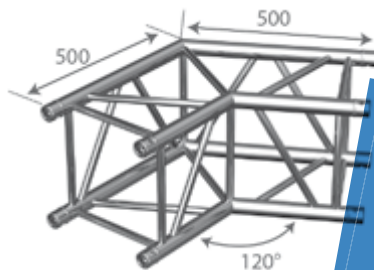
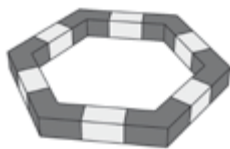

- + Quatro angle
- + 2 directions
- + 50 cm 120°

AGQUA-03

ref 10055



## ANGLE CONNECTION KITS

### AGQUA-04

ref 10056

- + Quatro angle
- + 2 directions
- + 50 cm 135°

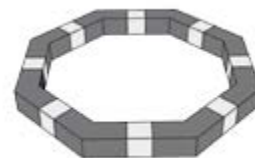
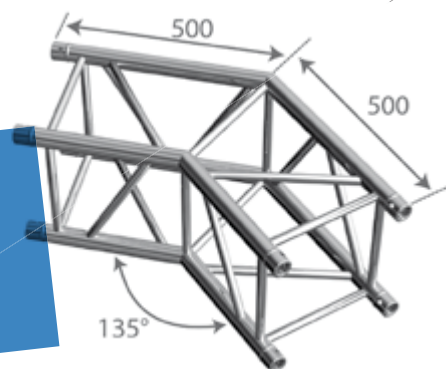

200

### AGQUA-05

ref 10057

- + Quatro angle
- + 3 directions 90°

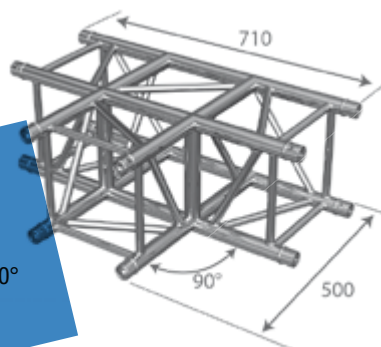

### AGQUA-06

ref 10058

- + Quatro angle
- + 4 directions

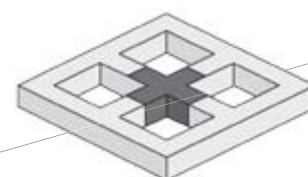
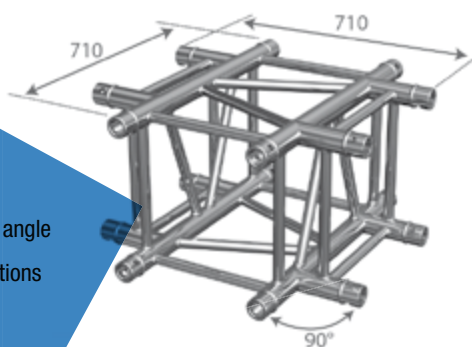

### AGQUA-07

ref 10059

- + Quatro connection kit
- + 5 directions

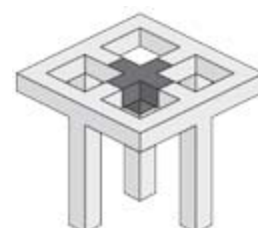
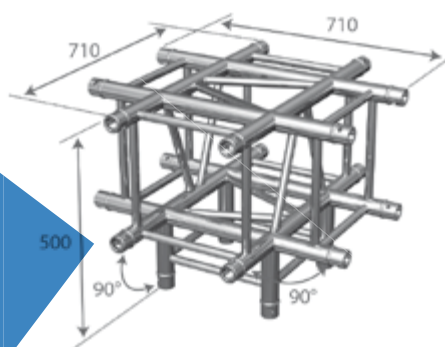



Contestage / Aluminium square truss

**Contest**®



## ANGLE CONNECTION KITS

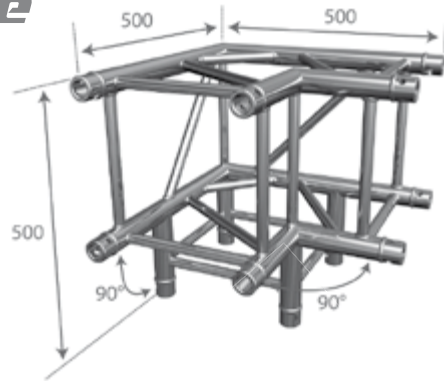
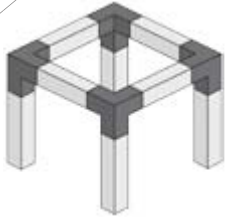

+ Quatro side piece  
+ 3 directions

### AGQUA-09

ref 10061

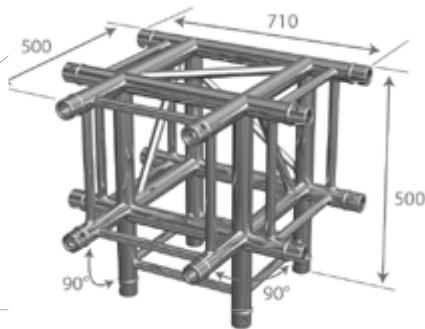
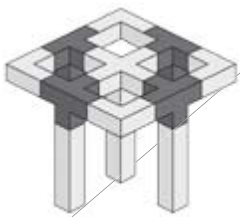

+ Quatro side piece  
+ 4 directions

### AGQUA-10

ref 10062

201

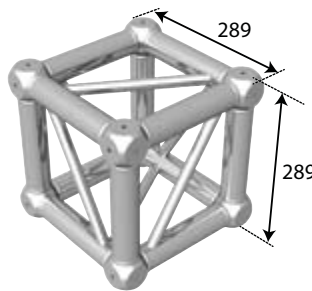
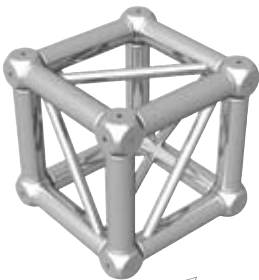

+ Quatro side piece  
+ 6 directions

### AGCUB290

ref 10433



### UNO-1/2MANCH

Extra half-connector  
ref 10254

## QUATRO ACCESSORIES

### MCQUA-KIT

ref 10063

+ 4 connectors, 8 pins  
and 8 safety pins kit



### EMQUA-B1

ref 10064



+ QUATRO  
baseplate with  
connectors

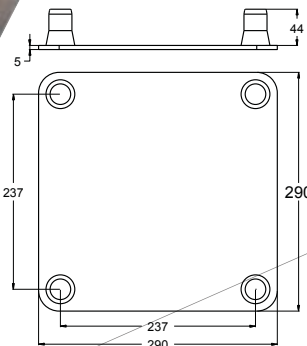

### EM29BLOU

ref 10463



+ Heavy baseplate  
for TRIO/  
QUATRO290  
structures  
D74cm for 29kg

# TRIO29

Aluminium triangular truss

ISO DIN 4113 and TÜV certified.

Made of 50mm aluminium alloy (EN AW 6082 T6, diameter 50 mm, thickness 2 mm).

The conical connectors and pins allow you to set it up quickly, and guarantee a very safe, stable and resistant installation. Disassembling it is also very quick.

- Width 290 mm.
- Tube diameter: 50 mm, thread: 16 mm.

This structure is supplied with:

- 1 x connection kit per truss
- 1 x connection kit per 2-direction angle
- 2 x connection kit per 3, 4 and 5-direction angle

202

Illuminate your square truss with

**MINITRUSS-6TCb**

See page 90 - ref 10365

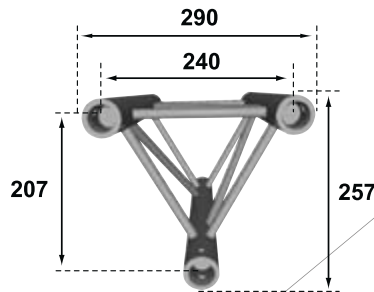

**PT29-029**

ref 4213



**PT29-050**

ref 3247

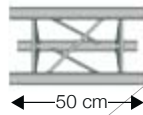

**PT29-071**

ref 10592

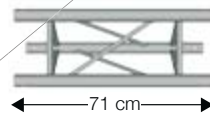

**PT29-100**

ref 3248

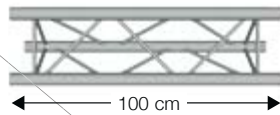

**PT29-200**



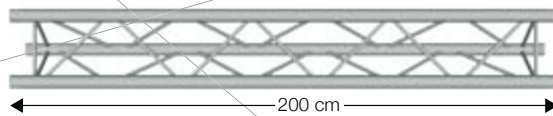

ref 3249

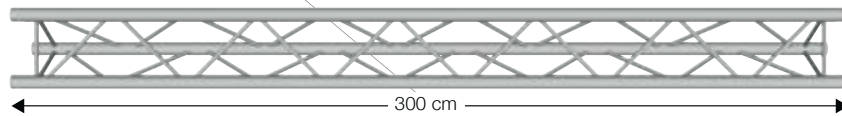

**PT29-300**

ref 3250



| LENGTH (M)                  |  | 2    | 4    | 6    | 8    | 10   | 12    |
|-----------------------------|---|------|------|------|------|------|-------|
| Max load (center) (kg)      |  | 1016 | 503  | 329  | 240  | 185  | 147   |
| Distortion (mm)             |  | 2,7  | 10,7 | 24,3 | 43,4 | 68,4 | 99,5  |
| Max distributed load (kg/m) |  | 783  | 251  | 110  | 60   | 37   | 25    |
| Distortion (mm)             |  | 2,6  | 13,4 | 30,1 | 53,5 | 83,6 | 120,4 |

Load tables indicate the maximum load-bearing capacity between two fixation points. Centered and distributed loads cannot be cumulated. Talk to a qualified engineer for more information.

## LES LIAISONS D'ANGLES

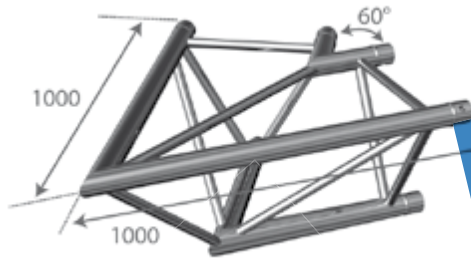

+ 290 mm angle  
+ 2 directions 60°

**AG29-020**

ref 7015

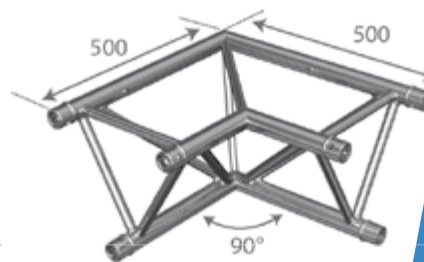
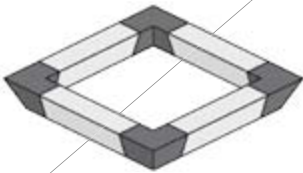

+ 290 mm angle  
+ 2 directions 90°

**AG29-021**

ref 3251

203

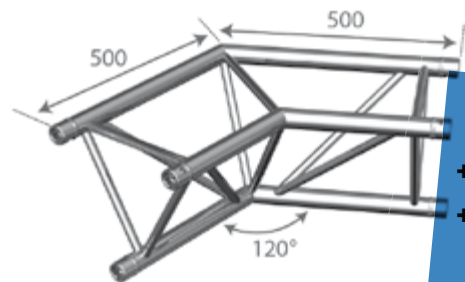

+ 290 mm angle  
+ 2 directions 120°

**AG29-022**

ref 7016

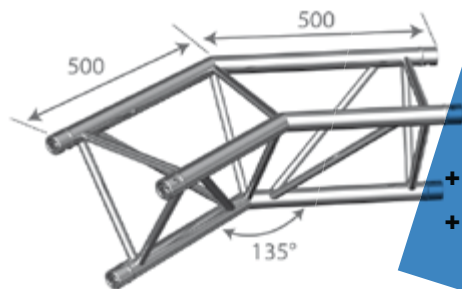

+ 290 mm angle  
+ 2 directions 135°

**AG29-023**

ref 3252

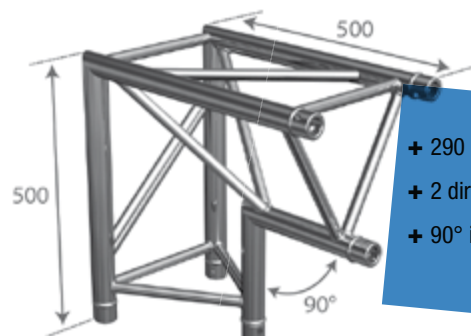
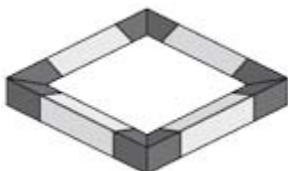

+ 290 mm angle  
+ 2 directions  
+ 90° inner vertex

**AG29-025**

ref 3253

## ANGLE CONNECTION KITS

### AG29-033

ref 3254

- + 290 mm angle
- + 3 directions
- + 90° low right-hand apex

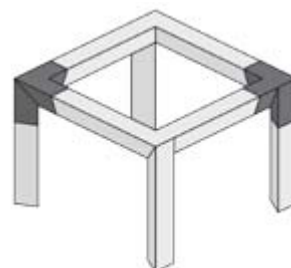
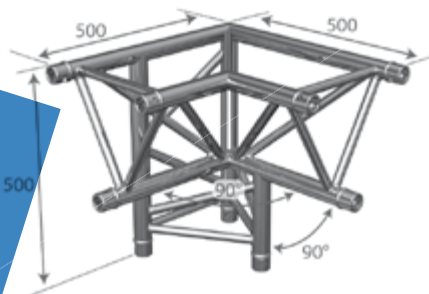

### AG29-034

ref 3255

- + 290 mm angle
- + 3 directions
- + 90° low left-hand apex

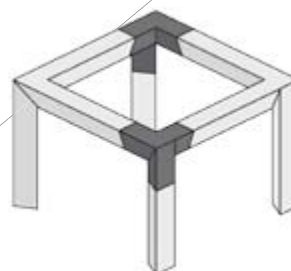
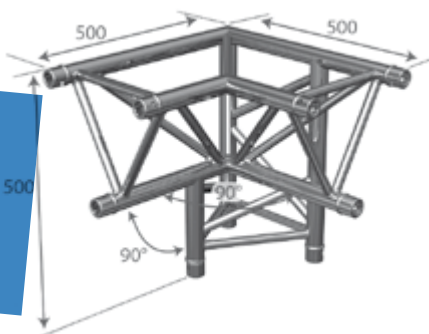

### AG29-035

ref 3256

- + 290 mm vertical Tee
- + 3 directions low apex

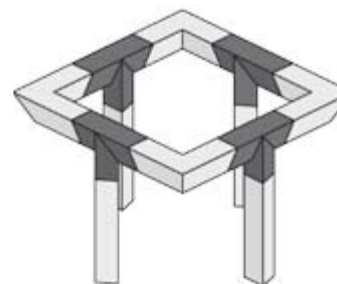
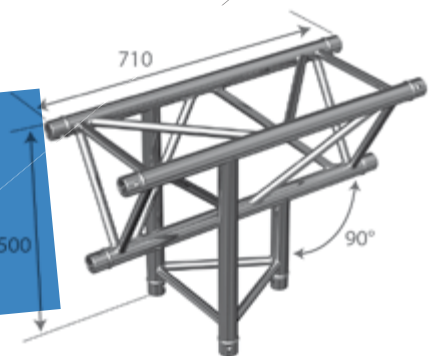

### AG29-036

ref 3257

- + 290 mm horizontal Tee
- + 3 directions

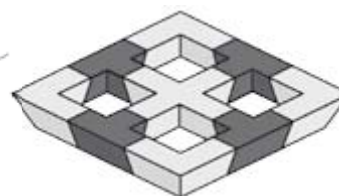
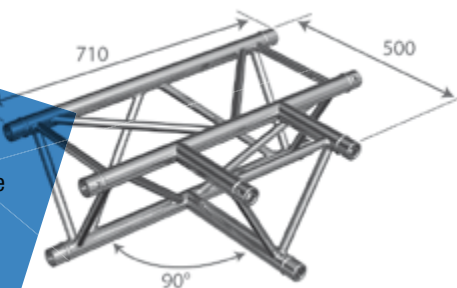

### AG29-041

ref 3258

- + 290 mm cross
- + 4 directions

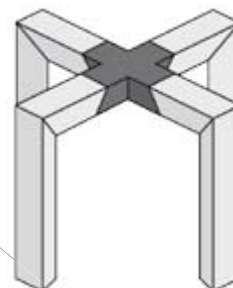
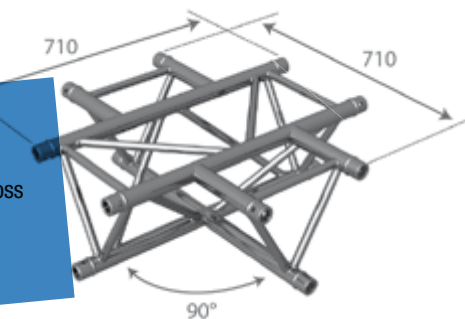





**ANGLE CONNECTION KITS**

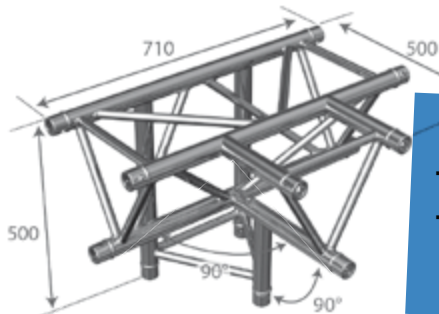
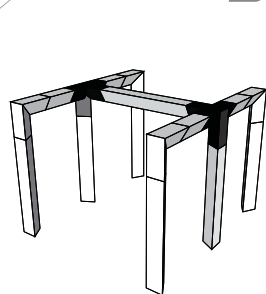

+ 290 mm Tee  
+ 4 directions  
low apex

**AG29-042**

ref 3259

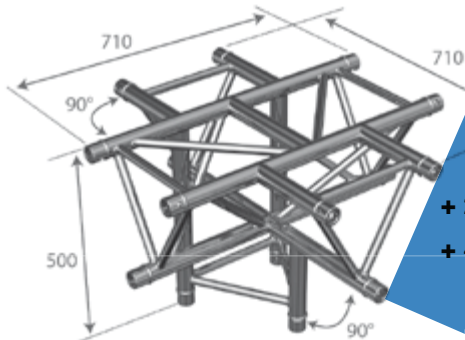
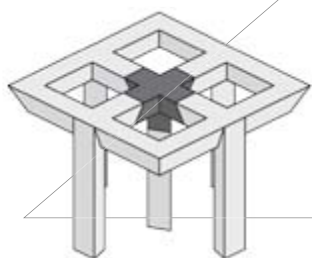

+ 290 mm angle  
+ 4 directions + leg

**AG29-053**

205

ref 4212

**TRIO ACCESSORIES**

**MC29-KIT**

ref 3261



+ 3 connectors, 6 pins  
and 6 safety pins kit

**EM29-B3**

ref 8684

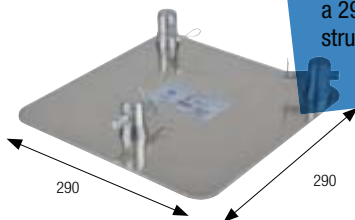

+ Baseplate with  
connectors for  
a 290 triangular  
structure

**EM29 BLOU**

ref 10463



+ Heavy baseplate  
for TRIO/  
QUATRO290  
structures  
D74cm for 29kg

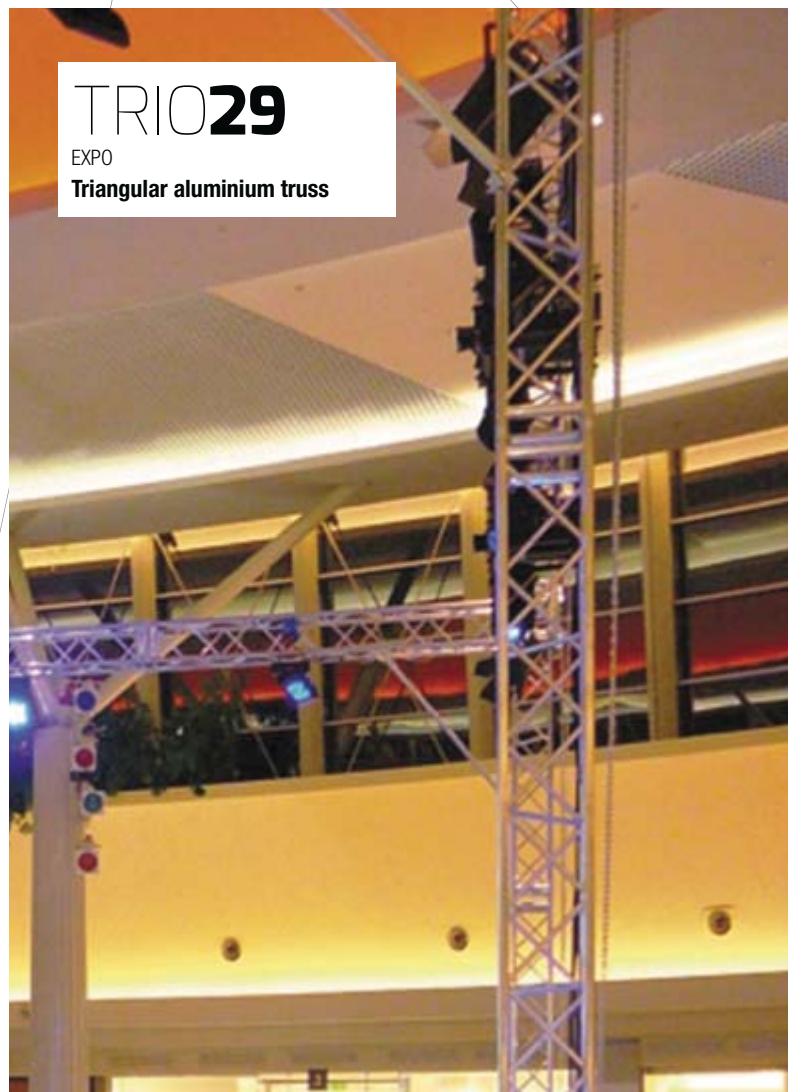

**TRIO29**

EXPO

Triangular aluminium truss

# DU029

Aluminium ladder

ISO DIN 4113 and TÜV certified.

Made of 50mm aluminium alloy (EN AW 6082 T6, diameter 50 mm, thickness 2 mm) .

Use the conical connectors for nomad and permanent installations.

The perfect equipment for expositions, banners, advertisements, or stage design.

- Width 290 mm.
- Tube diametre: 50 mm, thread: 16 mm.



206

This structure is supplied with :

- 1 x Connection kit per truss
- 1 x Connection kit per 2-direction angle
- 2 x connection kit per 3 and 4-direction angles

## DU029-029

ref 10036

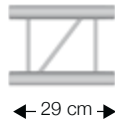

← 29 cm →

## DU029-050

ref 10037

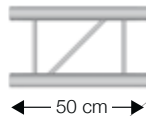

← 50 cm →

## DU029-071

ref 10607

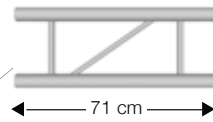

← 71 cm →

## DU029-100

ref 10038

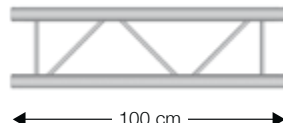

← 100 cm →

## DU029-200

ref 10039

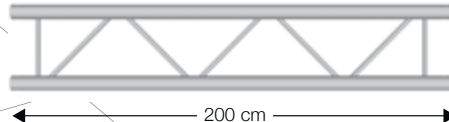

← 200 cm →



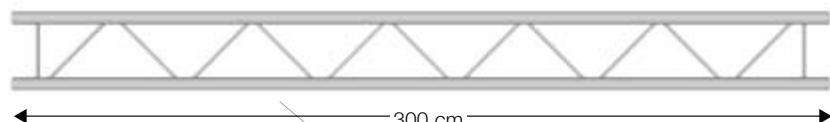

## DU029-300

ref 10040



← 300 cm →



| LENGTH (M)                  |  | 1   | 2   | 3   | 4  | 5  | 6  |
|-----------------------------|---|-----|-----|-----|----|----|----|
| Max load (center) (kg)      |  | 694 | 272 | 142 | 72 | 43 | 23 |
| Distortion (mm)             |  | 1   | 2   | 3   | 3  | 3  | 3  |
| Max distributed load (kg/m) |  | 694 | 251 | 94  | 36 | 17 | 7  |
| Distortion (mm)             |  | 1   | 2   | 3   | 4  | 5  | 6  |

Load tables indicate the maximum load-bearing capacity between two fixation points. Centered and distributed loads cannot be cumulated. Talk to a qualified engineer for more information

## AGDU029-01

ref 10041

- + Angle échelle
- + 2x90° right-oriented directions

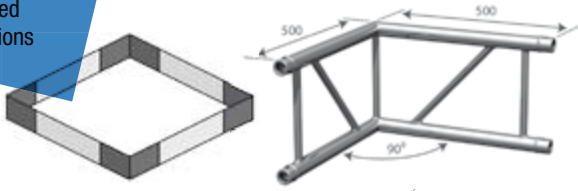

## AGDU029-02

ref 10042

- + Ladder angle
- + 2x90° vertically oriented directions

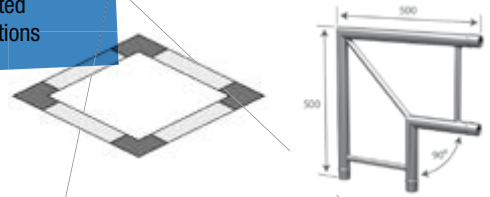

## AGDU029-03

ref 10043

- + Ladder angle
- + 3x90° flat directions

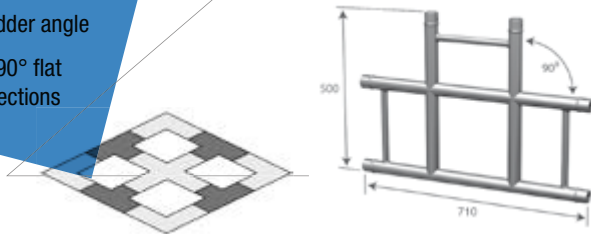

## AGDU029-04

ref 10044

- + Ladder angle
- + 3x90° right-oriented directions

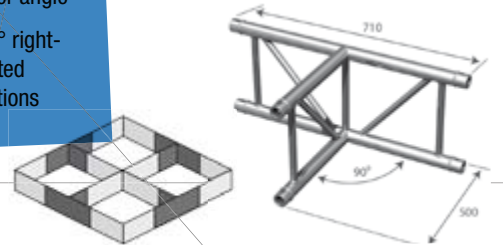

## AGDU029-05

ref 10045

- + Ladder angle
- + 4x90° flat directions

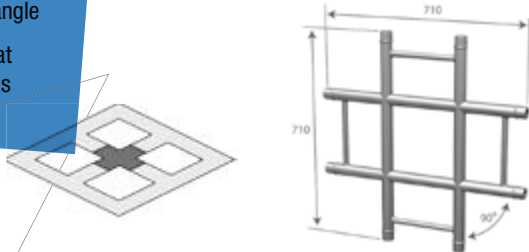

## AGDU029-06

ref 10046

- + Ladder angle
- + 4x90° right-oriented directions

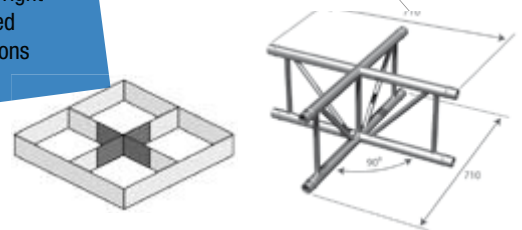

### DUO ACCESSORIES

## MCDUO-KIT

ref 10047

- + 2 connectors, 4 safety pins and 4 pins kit

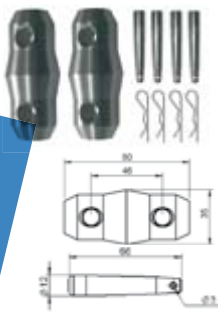

## EMDUO-B1

ref 10048

- + DUO baseplate with 2 connectors

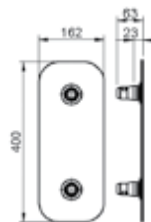

## EM29BLOU

ref 10463

- + Heavy baseplate for TRIO/QUATRO290 structures D74cm for 29kg



## SSL-DUO

Support for DU029 ladder with 35mm  
ref 10609



# UNO

Aluminium tube with a 50mm diameter

ISO DIN 4113 and TÜV certified.

Made of 50mm aluminium alloy (EN AW 6082 T6, diameter 50 mm, thickness 2 mm) .

The conical connectors and pins allow you to set it up quickly, and guarantee a very safe, stable and resistant installation. Disassembling it is also very quick.

The UNO series is really handy and intuitive thanks to its universal angle, and the different lengths available.

It will save you a lot of time and space. It can also be used to hold several projectors.



## UNO-AG01v2

Angle for 50mm tube. Supplied with 2 half-connectors.

ref 10612

208

This tube is supplied with :

- 1 x connector per tube
- 2 x connectors per angle



## UNO-1/2MANCH

Extra half-connector for UNO-AG01

ref 10254

UNO-50 in Alu.- ref 10238

UNO-50B in Black - ref 10417

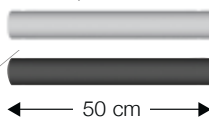

UNO-100 in Alu.- ref 10239

UNO-100B in Black - ref 10418

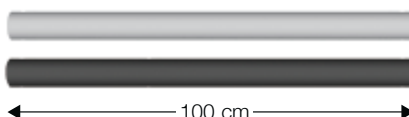

UNO-150 in Alu.- ref 10240



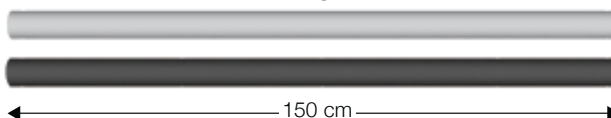

UNO-150B in Black - ref 10419

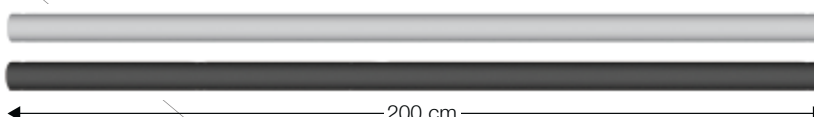

UNO-200 in Alu.- ref 10241

UNO-200B in Black - ref 10420



| LENGTH (M)                  |  | 1   | 2   | 3    | 4    |
|-----------------------------|---|-----|-----|------|------|
| Max load (center) (kg)      |  | 114 | 54  | 34,5 | 24,5 |
| Distortion (mm)             |  | 4   | 8   | 31   | 52   |
| Max distributed load (kg/m) |  | 224 | 109 | 73   | 52   |
| Distortion (mm)             |  | 5   | 37  | 126  | 280  |

Load tables indicate the maximum load-bearing capacity between two fixation points. Centered and distributed loads cannot be cumulated. Talk to a qualified engineer for more information.





## UNO-H

H-shaped projector truss with 50 mm pipes  
Max. load 100 kg  
ref : 10335

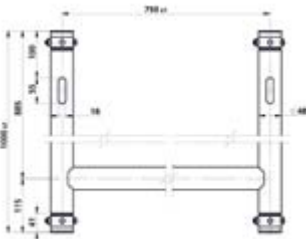

## UNO-T

Suspension Tee for projectors with 50mm pipes  
Max. load 100 kg  
ref : 10334

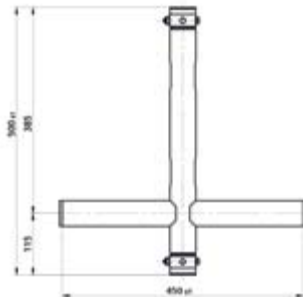

## UNO-A

Suspension bracket for projector with 50mm pipe  
Max load. 100 kg  
ref : 10336

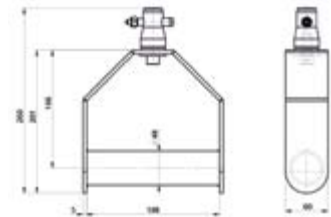

## EM29 BLOU

ref 10463



+ Heavy baseplate for TRIO/ QUATRO290 structures D74cm for 29kg

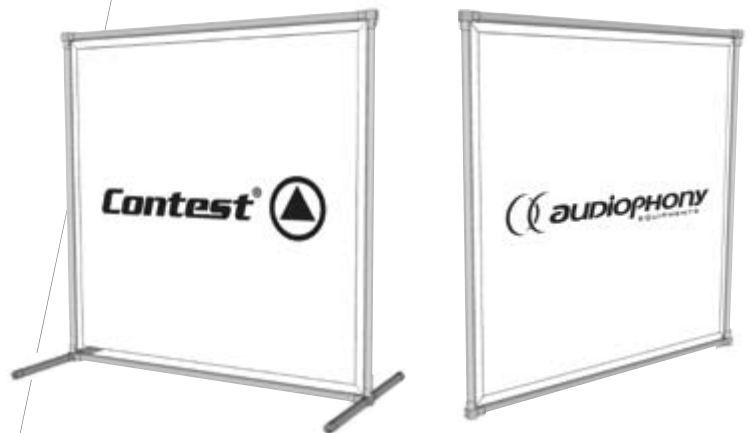

Self-standing structure and frame ideal for a canvas or an advertising billboard

# TOTEM

Complete set with baseplates, tubes, and white Lycra fabric

ISO DIN 4113 and TÜV certified.

Made of 50mm aluminium alloy (EN AW 6082 T6, diameter 50 mm, thickness 2 mm).

The Totems are supplied with a 50 mm aluminium pipes and a Lycra fabric.

You can show your projectors off placing another projector inside the totem without any unwanted shadow.

Supplied with :

- 4 x Tubes
- 2 x Baseplates
- 2 x Connection kits
- 1 x Lycra fabric



Several models available:  
 1 metre, 1.5 metre, 2 metres

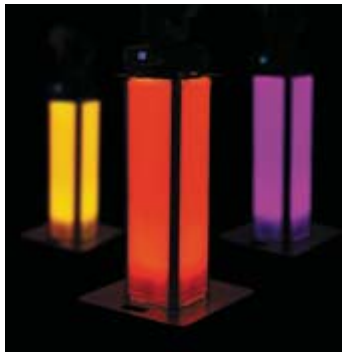
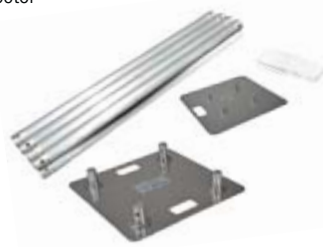

TOT-100

ref 10243

TOT-150

ref 10244

TOT-200

ref 10245

TOT-BASEground

Baseplate for 1 Totem, with 4 half-connectors

Ref : 10255

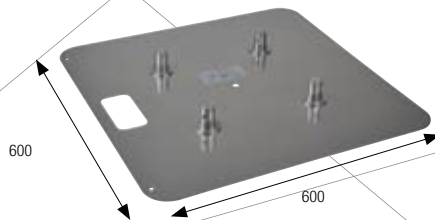

TOT-BASEtop

Top holding plate for 1 Totem, with 4 half-connectors

Ref : 10256

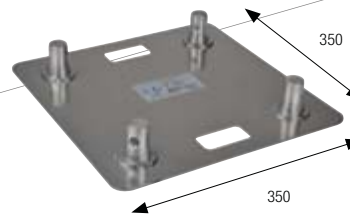

TOT-Spandex1

White fireproof Lycra fabric > for 1m Totem

ref 10257

TOT-Spandex1No

Black fireproof Lycra fabric > for 1m Totem

ref 10740

TOT-Spandex1,5

White fireproof Lycra fabric > for 1.5 m Totem

ref 10258

TOT-Spandex1,5No

Black fireproof Lycra fabric > for 1.5 m Totem

ref 10741

TOT-Spandex2

White fireproof Lycra fabric > for 2m Totem

ref 10259

TOT-Spandex2NO

Black fireproof Lycra fabric > for 2m Totem

ref 10742



# DECO-22

Structurez votre espace\*

\*Structuring your space

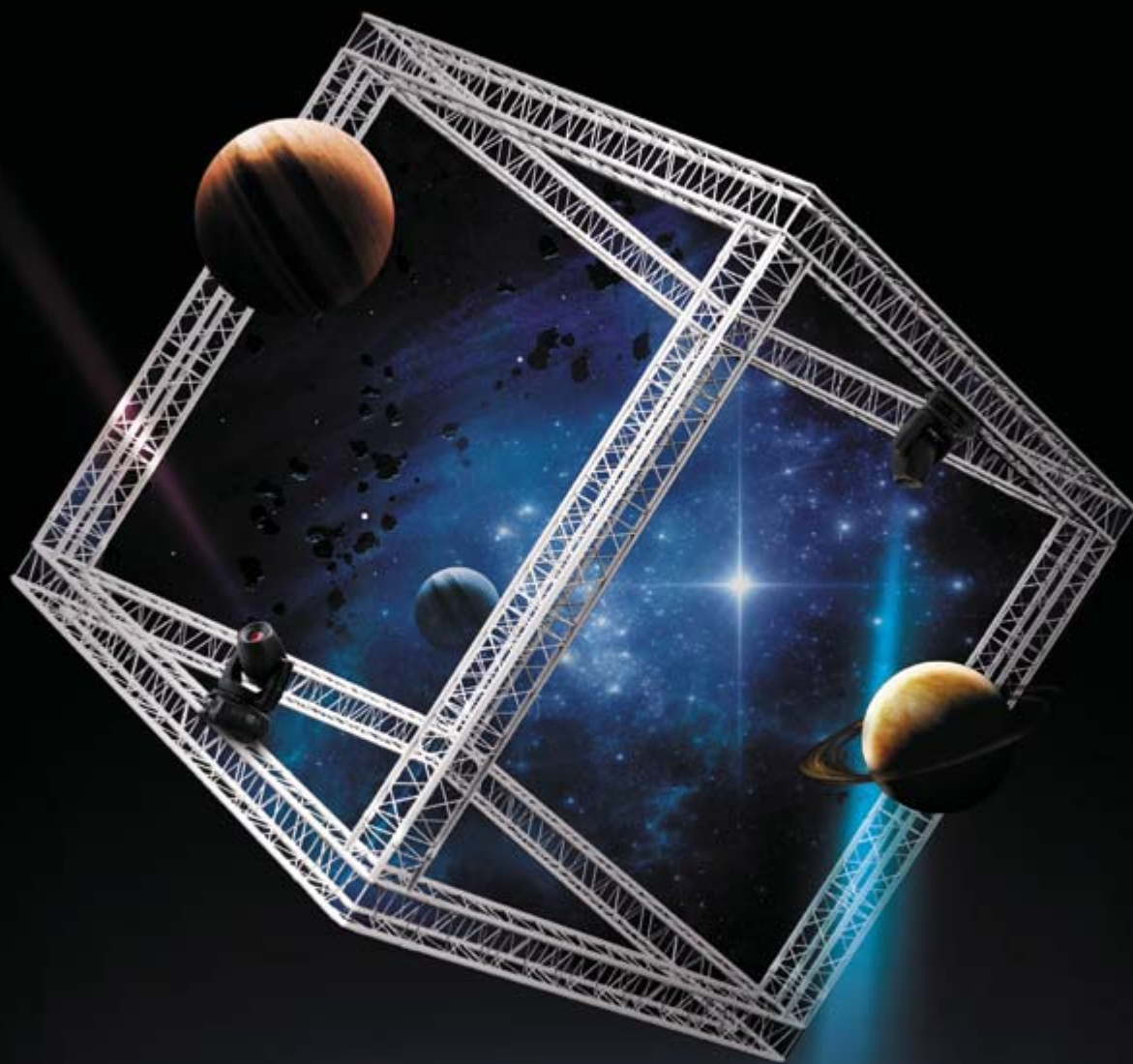

by  **Contestage**

# DECO22

DECO series aluminium square trusses

ISO DIN 4113 and TÜV certified.

Made of 35mm aluminium alloy (AL 6060-T diameter 35 mm, thickness 1.6 mm).

This is the series you need for your shop, exhibition stand or decorations.



212

This structure is supplied with :

- 1 x connection kit per bar
- 1 x 2-direction angle connection kit
- 2 x 3-4 direction angle connection kit

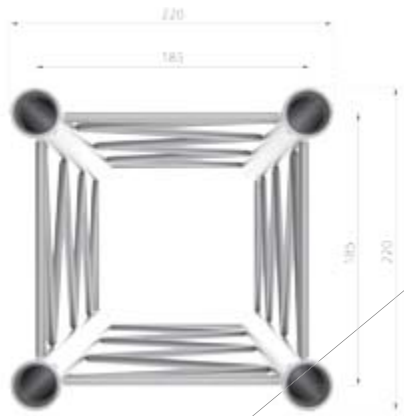

## DECO22Q-PT50

ref 10218

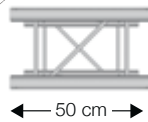

## DECO22Q-PT100



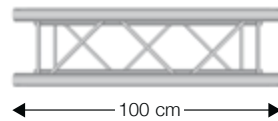

ref10219

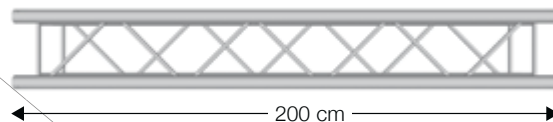

## DECO22Q-PT200

ref 10220



| LENGTH (M)                  |  | 1      | 2      | 3      | 4      | 5      | 6      |
|-----------------------------|---|--------|--------|--------|--------|--------|--------|
| Max load (center) (kg)      |  | 257,67 | 198,02 | 160,79 | 135,35 | 116,86 | 102,81 |
| Distortion (mm)             |  | 0,1    | 0,8    | 2,2    | 4,4    | 7,4    | 11,3   |
| Max distributed load (kg/m) |  | 420    | 208    | 137,33 | 99,24  | 65,20  | 45,94  |
| Distortion (mm)             |  | 0,1    | 1,1    | 3,5    | 8,1    | 13     | 19     |

Load tables indicate the maximum load-bearing capacity between two fixation points. Centered and distributed loads cannot be cumulated. Talk to a qualified engineer for more information.





**ANGLE CONNECTION KITS**

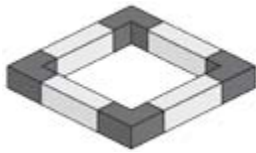

+ 220 mm angle  
+ 2x90° directions

**DECO22Q-AG01**

ref 10221

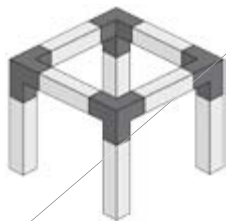

+ 220 mm angle  
+ 3 directions  
+ 3x90° side-oriented directions

**DECO22Q-AG02**

ref 10222

213



+ 220 mm angle  
+ 3 directions  
+ 3x90° horizontal directions

**DECO22Q-AG03**

ref 10223

**DECO22 ACCESSORIES**

**1. DECO22Q-MCKIT**

4 connectors, 8 safety pins and 8 pins kit  
ref 10224

**2. DECO22Q-EM-B1**

22x22 baseplate with fasteners for DECOqua series  
ref 10225

**3. DECO22-EMB-B3**

60x60 baseplate for DECO22T and DECO22Q  
ref 10606

**4. DECO22-CLAV**

Pin for DECO series conical connectors  
ref 10227

**5. DECO22-MANCH**

Conical connector for Déco series structures  
ref 10226

**6. DECO22-GOUP**

Safety pin for Déco series  
ref 10228

**7. DECO22-1/2MANCH**

M8 conical half-connector for 35mm tube  
ref 10332

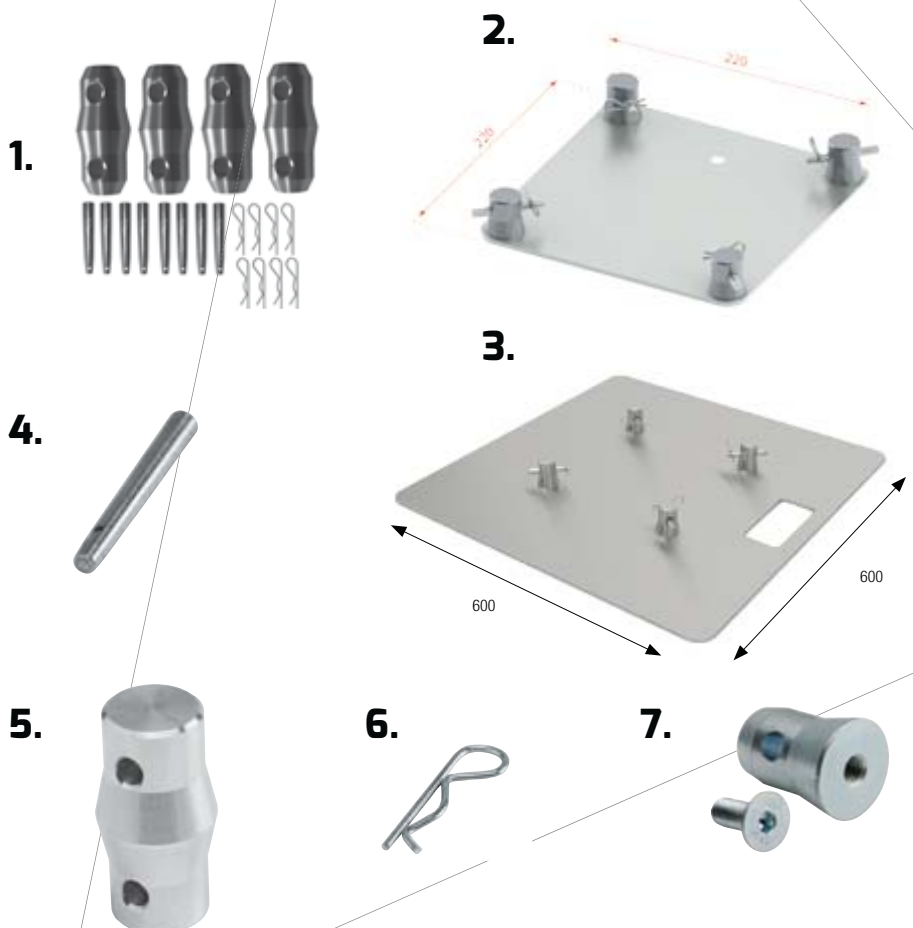

# DECO22

Deco series: triangular aluminium series

ISO DIN 4113 and TÜV certified.

Made of 35mm aluminium alloy (AL 6060-T diameter 35 mm, thickness 1.6 mm).

This is the series you need for your shop, exhibition stand or decorations.

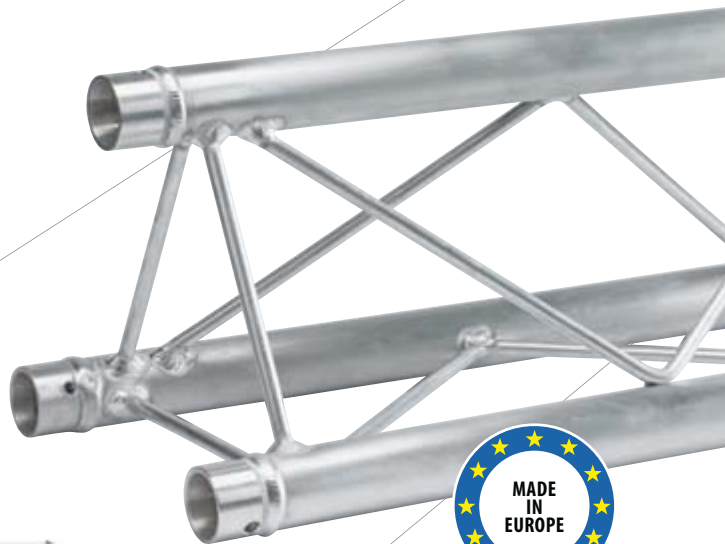

214

This structure is supplied with :

- 1 x bar connection kit
- 1 x 2 directions angle connection kit
- 2 x 3 and 4-direction angle connection

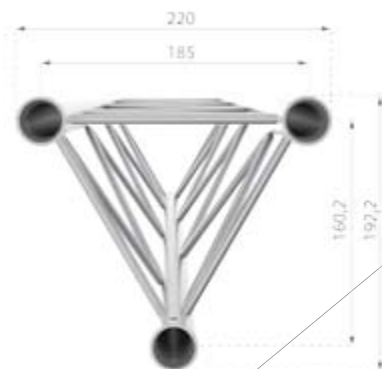

## DECO22T-PT50

ref 10229

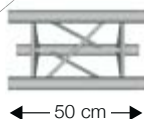

## DECO22T-PT100



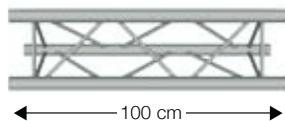

ref10230

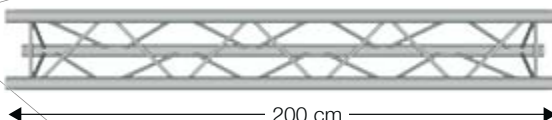

## DECO22T-PT200

ref 10231



| LENGTH (M)                  |  | 1      | 2      | 3      | 4      | 5      | 6     |
|-----------------------------|---|--------|--------|--------|--------|--------|-------|
| Max load (center) (kg)      |  | 263,98 | 198,09 | 158,52 | 132,12 | 113,27 | 99,12 |
| Distortion (mm)             |  | 0,3    | 1,6    | 4,3    | 8,6    | 14,3   | 21,7  |
| Max distributed load (kg/m) |  | 365    | 182    | 121    | 90,50  | 59,16  | 40,78 |
| Distortion (mm)             |  | 0,2    | 1,8    | 6,2    | 14,7   | 23,4   | 33,5  |

Load tables indicate the maximum load-bearing capacity between two fixation points. Centered and distributed loads cannot be cumulated. Talk to a qualified engineer for more information.



**CORNER JOINTS**

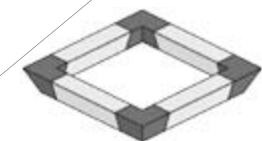

+ 220 mm angle  
+ 2 directions  
90°

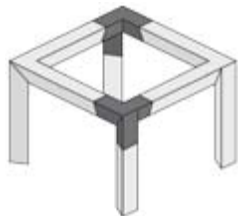

+ 220 mm angle  
+ 3 directions  
+ 3 x 90° right-oriented

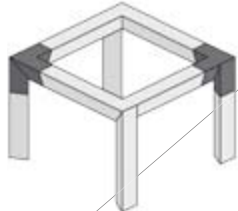

+ 220 mm angle  
+ 3 directions  
+ 3x90° left-oriented

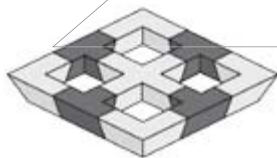

+ 220 mm angle  
+ 3 directions  
+ 3 x 90° flat

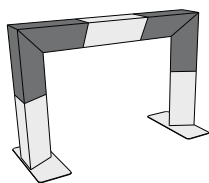

+ 220mm angle  
+ 2 directions  
+ 2x90 vertical directions

**DECO22T-AG01**

ref 10232

**DECO22T-AG02**

ref 10233

**DECO22T-AG03**

ref 10234

**DECO22T-AG04**

ref 10235

**DECO22T-AG05**

ref 10331

**1. DECO22T-MCKIT**

3 connectors, 6 safety pins and 6 pins kit  
ref 10236

**2. DECO22T-EM-B1**

22x22 baseplate with fasteners for DECOtrio series  
ref 10237

**3. DECO22T-EM-B2**

64x24 rectangular baseplate for Deco trusses -  
For 35mm pipes  
ref 10333

**4. DECO22-EMB-B3**

60x60 baseplate for DECO22T and DECO22Q  
ref 10606

**5. DECO22-CLAV**

Pin for DECO series conical connectors  
ref 10227

**6. DECO22-MANCH**

Conical connector for Déco series aluminium structure  
ref 10226

**7. DECO22-1/2MANCH**

M8 conical half-connector for 35mm tube  
ref 10332

**8. DECO22-GOUP**

Safety pin for Déco series  
ref 10228

1.



3.

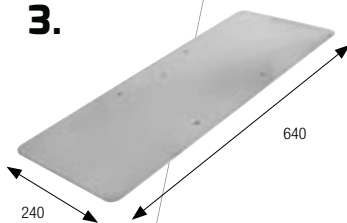

2.



4.

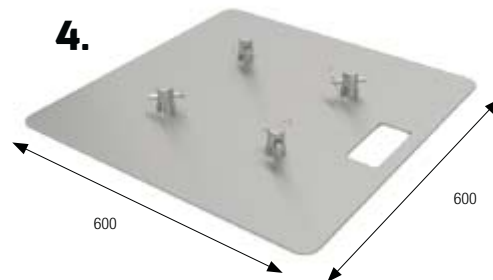

5.



6.



7.



8.



# DECO20

Triangular metal truss

Perfect for small lighting stand and light structures.

The high-quality finishing and the very robust materials we used make this structure very versatile.

It can be used for classic lighting installations, but also for shop decorations, exhibitions, etc ...

- Width: 205 mm.
- Tube diametre: 19 mm, thread: 5 mm.
- No connection kit required (screws supplied).



216

This structure is supplied with :

- 1 x connection kit per bar
- 1 x M8 screws kit to mount projectors

| LENGTH (M)                  |  | 1,5 | 3  | 4,5 | 6  | 7,5 |
|-----------------------------|---|-----|----|-----|----|-----|
| Max load (center) (kg)      |  | 100 | 80 | 59  | 45 | 30  |
| Max distributed load (kg/m) |  | 97  | 38 | 15  | 9  | 6   |

Load tables indicate the maximum load-bearing capacity between two fixation points.

Centered and distributed loads cannot be cumulated. Talk to a qualified engineer for more information.

## PT20-50

ref 10033

- + 200mm metal truss
- + Lenght 50 cm
- + 1 rigging points

## PT20-75

ref 10034

- + 200mm metal truss
- + Lenght 75 cm
- + 2 rigging points

## PT20-100

ref 10035

- + 200mm metal truss
- + Lenght 100 cm
- + 3 rigging points

## PT20-150

ref 8261

- + 200mm metal truss
- + Lenght 150 cm
- + 4 rigging points



- + Ground and wall baseplate for PT20-150 structures

## EM 20-BASE

ref 8267



## ANGLE CONNECTION KITS AND BASEPLATE

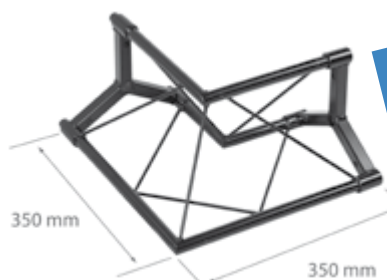
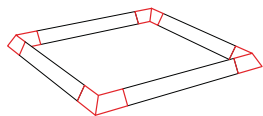

- + 200 mm angle
- + 2 directions 90°

**AG20-021**

ref B263

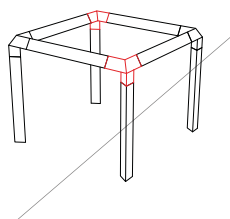

- + 200 mm angle
- + 3 directions 90°
- + top-hand apex

**AG20-033**

ref B264

217

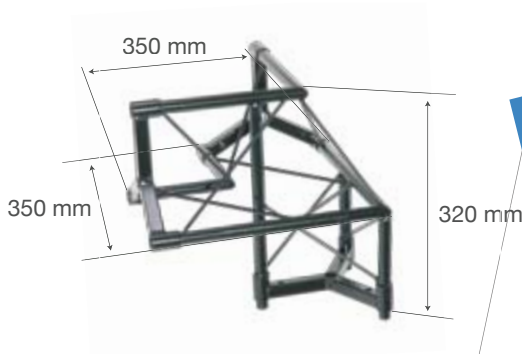
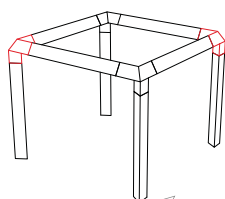

- + 200 mm angle
- + 3 directions 90°
- + top-hand apex

**AG20-034**

ref 10584

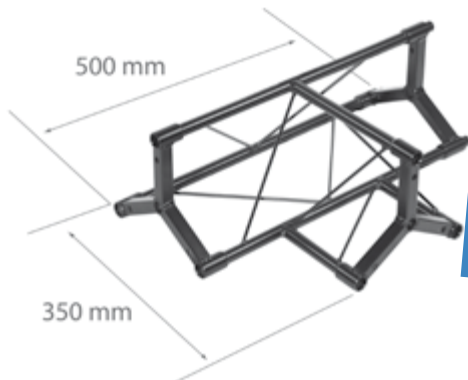
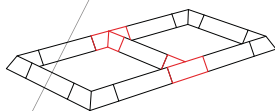

- + 200 mm vertical T
- + 3 directions low apex

**AG20-035**

ref B265

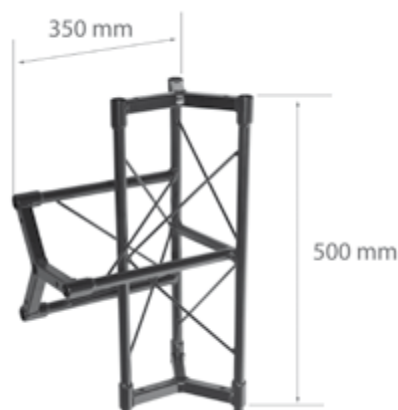
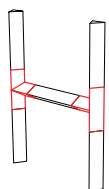

- + 200 mm horizontal T
- + 3 directions

**AG20-036**

ref B266

# ELV

Winch elevator stands

These self-locking winch stands feature high-quality components ensuring a great stability.

Transportation and installation have never been so easy with their 3 articulated legs.

Clamping knobs ensure a perfect tube locking.

218

- Certification : TÜV-approved
- Material : Hardened steel
- Finishing : Galvanized (grey) or epoxy paint (black)
- Tube diameter : Ø 35 mm
- Winch : Anti-reverse self-locking gear
- Cable : Galvanized steel

# ELV 270PRO

Self-locking winch stand

ref 9995

ISO DIN 4113 and TÜV certified. The Ø 35 mm pipe allows you to mount speakers, or use it for lighting stands if you add an horizontal truss (not supplied). This high-quality self-locking winch stand was made in Europe. The double leg reinforcements and the three robust legs ensure a great stability. The clamping knob perfectly locks the tubes.

|                             |      |
|-----------------------------|------|
| Max load (kg)               | 60   |
| Max height (m)              | 2,70 |
| Folded length (m)           | 1,60 |
| Weight(kg)                  | 12   |
| Galvanized steel cable (mm) | Ø 3  |





# ELV-400PRO

SCENE

**4m Self-locking winch elevator stand**  
**Height: 4m**

219

# ELV 400PRO

Self-locking winch elevator stand

ref 9996

ISO DIN 4113 and TÜV certified. This outstanding professional stand can be safely operated thanks to its double lock system with a clamping knob and a clevis pin for each tube. The legs ensure a great stability on all surfaces thanks to their double reinforcements. The stand folds and can be easily transported without taking any place. The clamping knobs ensure the tubes are not loose and perfectly locked.

|                             |      |
|-----------------------------|------|
| Max load (kg)               | 80   |
| Max height (m)              | 4    |
| Folded length (m)           | 1,59 |
| Weight(kg)                  | 23   |
| Galvanized steel cable (mm) | Ø 5  |

**RIGGING ACCESSORIES**

220



**BRE-50**  
Ø 50 mm Bar with a Ø 35 mm baseplate. Length: 1.50 m.  
ref 8845



**CCT-20**  
Projector hook clamp. Ø 20 mm tube.  
ref 7834



**CCT-50**  
Projector hook clamp. Ø 30-50 mm tube.  
ref 3242



**CCT-50B**  
Pro hook clamp for 30 to 50mm tubes - Black  
ref 10414



**CCT-52**  
Straight projector hook with protection Ø 30-50 mm  
ref 10330



**CCT-55**  
Projector hook clamp. Ø 30-50 mm  
with protection.  
ref 7835



**CCT-55B**  
Hook clamp +protection for 30 to 50mm tubes -Black.  
ref 10415



**GOUP**  
Safety pin.  
ref 6525



**SUP-PIL**  
Trust support with fastening  
chain  
ref 10608



**SSL-DUO**  
Support DUO29 ladder with 35 mm  
stand  
ref 10609



**1/2MANCH**  
Half-connector with a M12 thread.  
ref 6530



**STAND-FLOOR**  
Ground fixation plate for projector.  
ref 9116



**FLOOR4**  
Hanging bracket to hold a projector on the  
ground Magnésium series.  
ref 9666

**SAFETY CHAINS WITH A GALVANISED, AND PLASTICISED STEEL HOOK**



**ELG301**  
Ø 1mm black steel wire. L 30 cm. 1 quick-release clip. 15 kg SWL.  
ref 9967



**ELG602**  
Ø 2 mm black steel wire. L 60 cm. 1 quick-release clip. 50 kg SWL.  
ref 9969

**ELG0615**  
Sheathed cable diam 6mm length 150cm MWL400kg  
ref 10459

**ELG0620**  
Sheathed cable diam 6mm length 200cm MWL400kg  
ref 10460

**ELG0815**  
Sheathed cable diam 8mm length 150cm MWL700kg  
ref 10461

**ELG0820**  
Sheathed cable diam 8mm length 200cm MWL700kg  
ref 10462

**ELG1003**  
Ø 3 mm black steel wire. L100 cm 1 quick-release clip. 90 kg SWL.  
ref 9971

**ELG1015**  
Elingue gainée Ø 10 mm L 150 cm CMU 1000 kg  
ref 10444

**ELG1020**  
Sheathed cable diam 10mm length 200cm MWL1000kg  
ref 10445

**MAIL-750**  
Cable hook MWL750kg  
ref 10435



**EYE-10F**  
Female M10 eye bolt MWL230kg  
ref 10436



Steel Core  
Fire resistant



CLR-50  
Aluminium clamp for Ø 50 mm tubes.  
ref 7836



CLR-50B  
Aluminium collar for 50mm tubes-Black  
ref 10416



CLR-100  
Double clamp for Ø 50 mm tubes.  
ref 10028



SHA-01  
High resistance shackle. 2000 kg SWL.  
ref 10029



HOOK-1000  
Omega shackle MWL1000kg  
ref 10434



SAN-00  
Ratchet tie-down strap 5m MWL2000kg  
ref 10441



SAN-01  
16m safety belt. 2000 kg SWL.  
ref 10030



SAN-02  
Ratchet span band. 2000 kg SWL.  
ref 10031



SAN-03  
1,5m round sling. 2000 kg SWL.  
ref 10032



SAN-04  
Textile tubular webbing, working length 1.5m 1000kg  
ref 10437



SAN-05  
Tubular webbing, working length 2m 1000kg  
ref 10438



SAN-06  
Tubular webbing with steel core, working length 1.5m  
1000kg  
ref 10439



SAN-07  
Tubular webbing with steel core, working length 2m  
1000kg  
ref 10440



1/2MANCH-M10  
Conical half-connector with M10 thread for 50 mm  
tubes  
ref 10323



CLR-35  
Aluminium clamp for Ø 35 mm tubes - Load 50 kg  
ref 10324



CLR-70  
Aluminium double clamps for Ø 35 mm tubes Load  
50 kg  
ref 10325



CLR-150  
Aluminium clamp for Ø 50 mm tubes Load 100 kg  
ref 10326



CLR-250  
Aluminium double clamps for Ø 50 mm tubes Load  
100 kg  
ref 10327



CLP-50-S  
Aluminium hook clamp for 50mm tubes Load 120kg  
- Silver  
ref 10328



CLP-50-B  
Aluminium hook clamp for 50mm tubes Load 120kg  
- Black  
ref 10329



CLP-250-S  
Aluminium hook clamp for 50mm tubes Load 250kg  
- Silver  
ref 10347



CLP-250-B  
Aluminium hook clamp for 50mm tubes Load 250kg  
- Black  
ref 10348



EM29BLOU  
Heavy baseplate for TRIO/QUATRO290 structures D74cm for 29kg  
ref 10463

# POT-DJ

DJ sound and lighting set: - W : 1.20 m - H : 2.50 m  
ref 8257

Never has it been so simple to set up a complete DJ sound and lighting stand. It only requires 15 minutes as each part fits in with an extreme simplicity. The horizontal trusses features 6 holes and supplied with all the necessary screws. Once folded, the POT-DJ fits in a single transport case: the POT-BAG.

- + DJ sound and lighting set
- + Perfect for small venues requiring a quick installation and a limited size
- + This set allows you to quickly set up a real DJ stand and lighting truss

222

## TECHNICAL SPECIFICATIONS

|  |
|--|
| Net weight : 18.5 kg                     |
| Lighting set height : 2.15-2.51 m        |
| Lighting set height: 2.4 m               |
| Sound set height : 83 cm                 |
| Sound set width : 1,2 m                  |
| Bar cross-section : 30 x 30 mm           |
| Projector slots : 12                     |
| Max distributed load : 50 kg             |
| Materials : - Steel - ABS clamping knobs |
| Finishing : Matte black epoxy paint      |

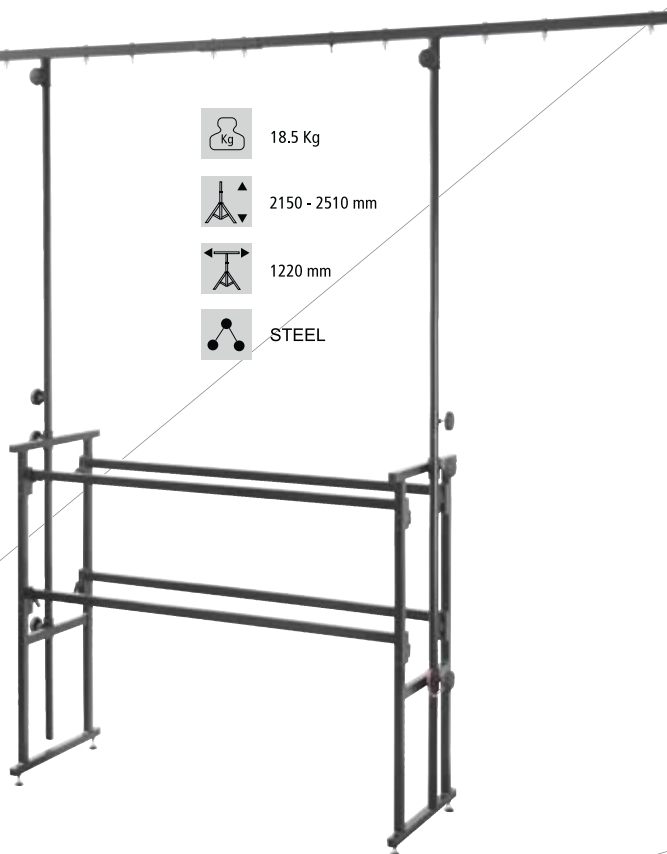

# POT-BAG

Transport case  
ref 8260



The POT-BAG allows you to store and transport the whole POT-DJ set. Each part has its own storage compartment and the long bag handles have been designed to transport the POT-DJ safely and conveniently. Material: Nylon.

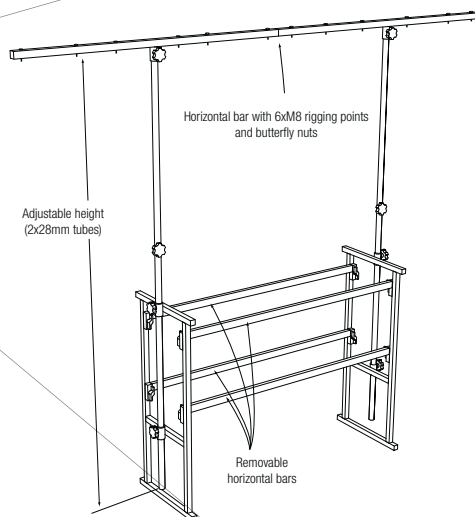







# POT-330

Lighting structure with steel trusses - W : 3 m - H : 3.20 m

**The perfect equipment to quickly set up a lighting truss system**

ref 8259

- + It is extremely reliable, easy-to-use, and light thanks to high-quality materials and its superior design
- + The horizontal steel trusses can mount up several projectors
- + Screws supplied

-  21.6 Kg
-  80 Kg Distributed load
-  1490 - 3180 mm
-  28 mm
-  1200 mm
-  STEEL
-  3000 mm

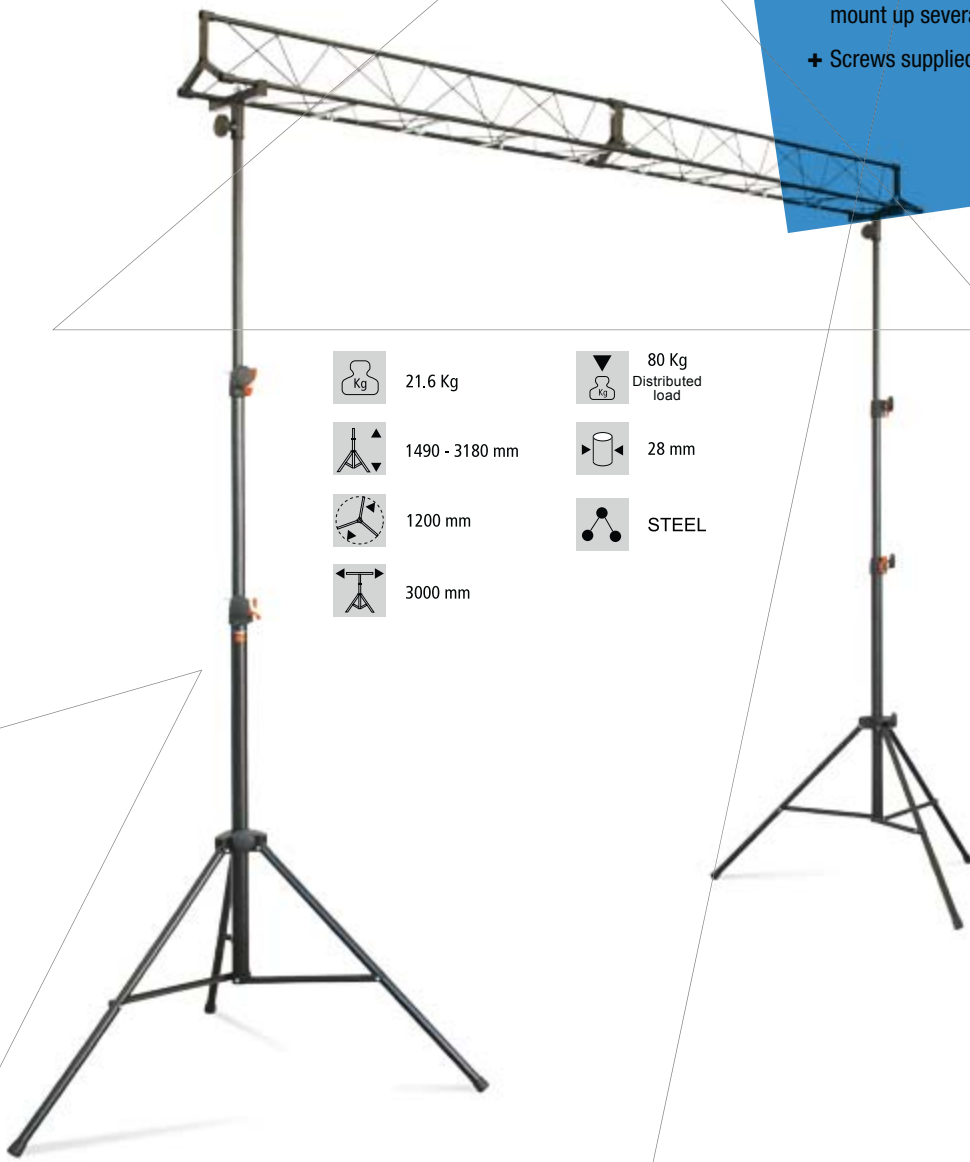



## TECHNICAL SPECIFICATIONS

|   |                                     |
|---|-------------------------------------|
| Net weight : 21.6 kg                      | Pipes diameter : 28 mm              |
| Lighting set height : 1.49-3.18 m         | Materials :                         |
| Lighting set width : 3 m (2x1.5m trusses) | - Steel                             |
| Projector slots : 10                      | - ABS clamping knobs                |
| Max distributed load : 80 kg              | Finishing : Matte black epoxy paint |
| Base spread diameter : 1.2 m              |                                     |

# PID-100

All-metal lighting stand with double leg reinforcements  
ref B252

-  5.3 Kg
-  30 Kg
-  1230 mm
-  28 mm
-  1480 - 3130 mm
-  STEEL
-  1400 mm

## TECHNICAL SPECIFICATIONS

- Net weight : 5.3 kg
- Height : 1.48-3.13 m
- Folded height : 1.23 m
- Base spread diameter : 1.4m
- Max load : 30 kg
- Pipe diameter : 28 mm
- Horizontal bar length : 1 m

- Double leg reinforcements
- Materials :
  - Pipes, fixations and reinforcements: steel
  - Tubes ends: rubber
  - ABS clamping knobs
- Finishing : Matte black epoxy paint









- + Height 3 m, ø28 mm
- + Steel lighting stand with 2 fixations and double leg reinforcements
- + Max load : 30 kg



224

# PID-240

All-metal lighting stand + beam: - Height 2.40 m ø28 mm  
ref B253

-  6.7 Kg
-  1000 mm
-  1230 mm
-  20 Kg Distributed load
-  1490 - 2400 mm
-  28 mm
-  1200 mm
-  STEEL

## TECHNICAL SPECIFICATIONS

- Net weight : 6.7 kg
- Height : 1.49-2.40 m
- Folded height : 1.23 m
- Base spread diameter : 1,2 m
- Max load : 30 kg
- Pipe diameter: 28 mm

- Horizontal pipe length : 1 m
- Single leg reinforcement
- Materials :
  - Steel and magnesium
  - Rubber pipe extremities
  - ABS clamping knobs
- Finishing : Matte black epoxy paint

- + High quality lighting stand with a metal horizontal pipe - Height 2.40 m, ø28 mm
- + 2 fixations, steel single leg stand
- + Supplied with a beam allowing you to mount up to 4 projectors, and screws

## RIGGING ACCESSORIES (PID-100&240)



### SST-20

200mm support for Ø 28 mm beams.  
Only for the PT20-150  
ref B262



### BRE-120

Ø 28 mm Lighting beam  
ref B256



### CPL-28

Reinforced adapter for Ø28 mm stands. M8 thread  
ref B255



# PID-380

3m stand with bar, maximum load : 80 kg  
ref 8253

## TECHNICAL SPECIFICATIONS

Net weight: 11.2 Kg  
Height: from 1,87 to 3 m  
Height once folded: 1,59 m  
Base spread diameter: 1,3 m  
Max. load: 80 Kg  
Pipe diameter: 35 mm  
Horizontal pipe length: 1,5 m

Horizontal pipe diameter: 35 mm  
Double leg reinforcement  
Materials  
Steel pipes and reinforcements  
Rubber pipe extremities  
ABS clamping knobs  
Finishing: Matte black epoxy paint

- + Max. height of 3m
- + Max. load of 80kg
- + Steel legs
- + 35mm pipe

## RIGGING ACCESSORIES (PID-380)



### CPL-12

Reinforced adaptater for Ø35 mm stands. M10 thread  
ref 3239

## ACCESSORIES

### PID1-BAG

Storage bag for 1x lighting stand  
PID-240 or PID-100 compatible  
ref 10012

### PID2-BAG

Storage bag for 2x lighting stand  
PID-240 or PID-100 compatible  
ref 10012

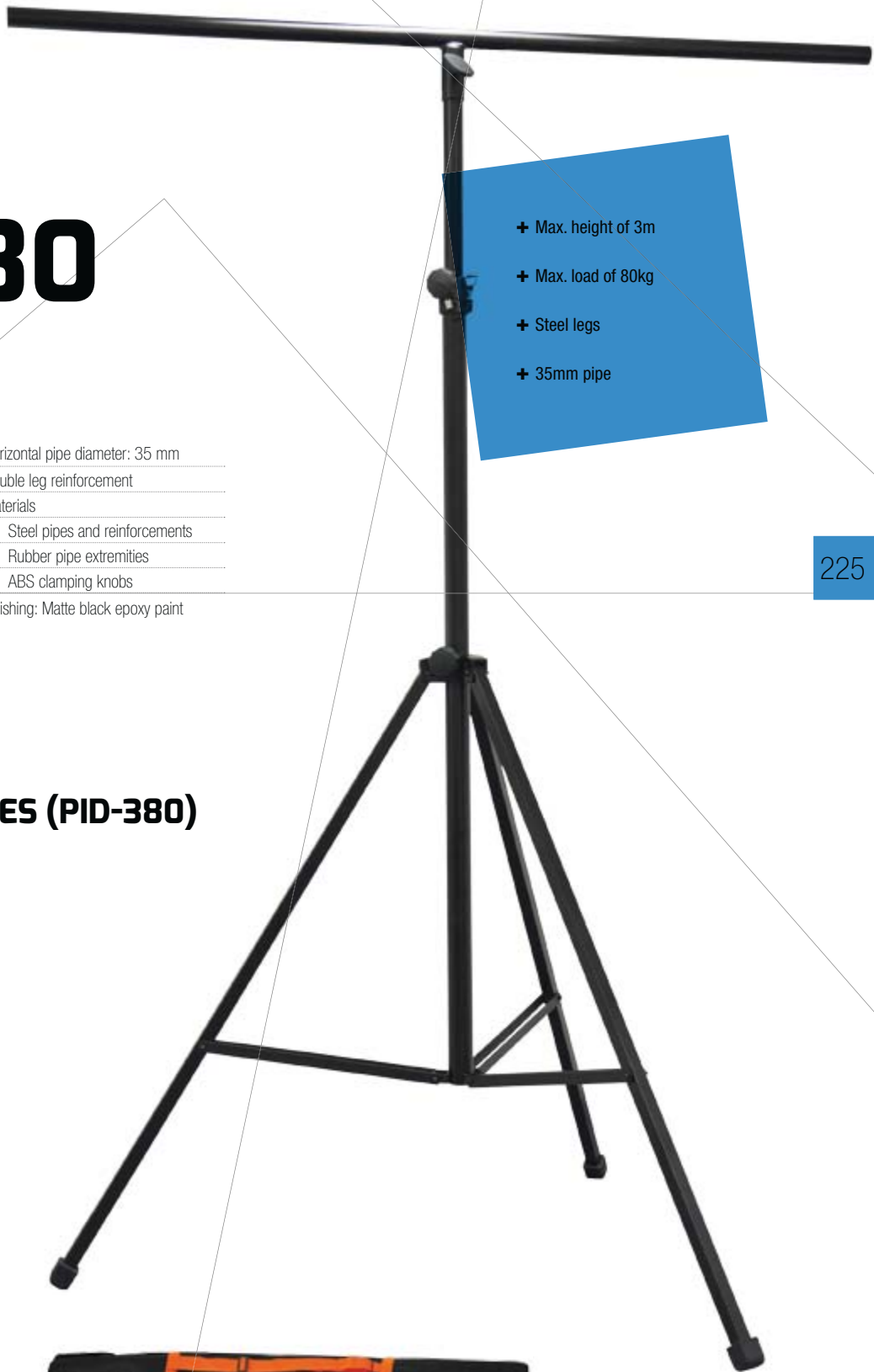



# WE CARE ABOUT OUR CUSTOMERS IT IS LIFE-CHANGING!

More and more Contest® fittings are used every day. We are building a reputation over the years, and customer service is our backbone.

## WHAT WE MEAN BY «CUSTOMER SERVICE» :

- A product developed by a team listening to the user's needs
- An innovative product
- Our distribution network will advise you, reassure you, and potentially give you a demonstration
- Your will always find spare parts for your Contest® so you can maintain your product in the long run

---

We care about you from the beginning to the end. Sometimes you will not see it, because it is only when we really need it that we can judge of the quality of a customer service. We know it, and every year we work hard to improve our products and our customer care.

Contest® is a guarantee of having reliable, well-thought products at a fair price and with a customer service who really cares.

**OUR CUSTOMER  
SERVICE DOES NOT  
STOP ONCE WE SOLD  
YOU A PRODUCT... IT  
REALLY KICKS IN  
AFTERWARDS**

# LAMPS



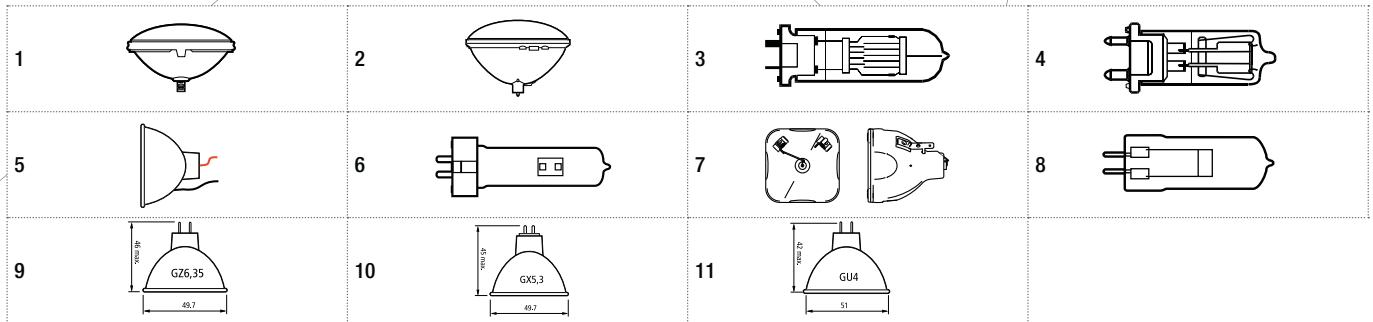



### PAR LAMPS

|   | REF  | NAME        | TYPE     | ANSI | BRAND | WATTS | VOLTS | FOOT  | ANGLE     | KELVIN | LIFESPAN |
|---|--|-------------|----------|------|-------|-------|-------|-------|-----------|--------|----------|
| 1 |  0132 | LPAR36 4515 | 4515     | -    | GE    | 30    | 6,4   | VIS   | 5° X 5°   | 3000   | 100      |
| 2 | 0131   | LPAR56 MFL  | PAR56MFL | MFL  | GE    | 300   | 240   | GX16D | 23° x 11° | 3000   | 2000     |
|   | 8662   | LPAR56 WFL  | PAR56WFL | WFL  | GE    | 300   | 240   | GX16D | 37° x 20° | 3000   | 2000     |



### THEATRE LAMP

|   | REF  | NAME           | TYPE        | ANSI | BRAND   | WATTS | VOLTS | FOOT  | ANGLE | KELVIN | LIFESPAN |
|---|--|----------------|-------------|------|---------|-------|-------|-------|-------|--------|----------|
| 3 | 0296   | GY9,5500       | 6873 - CP82 | FRH  | OSRAM   | 500   | 240   | GY9,5 | 3200  | -      | 150      |
|   | 0297   | GY9,5650 T27   | 6823 - T27  | GCK  | OSRAM   | 650   | 240   | GY9,5 | 3000  | -      | 400      |
|   | 0295   | GX9,51000      | 6995 - CP70 | FVA  | OSRAM   | 1000  | 240   | GX9,5 | 3200  | -      | 200      |
| 4 | 2590   | GX9,51000/T19  | 6996 - T19  | FWP  | OSRAM   | 1000  | 240   | GX9,5 | 3000  | -      | 750      |
|   |  9011 | LR7S / 118-500 | R7S         | -    | CONTEST | 500   | 240   | R7S   | 2900  | 9000   | 2000     |



### DISCHARGE LAMPS

|   | REF  | NAME        | TYPE             | BRAND   | WATTS | VOLTS | FOOT  | ANGLE | KELVIN | LIFESPAN |
|---|--|-------------|------------------|---------|-------|-------|-------|-------|--------|----------|
| 5 |  8984 | LHID-150    | HID150           | CONTEST | 150   | 95    | FIL   | 12°   | 6500   | 1000     |
| 6 |  8994 | LMSD-250/2  | MSD250/2         | CONTEST | 250   | 94    | GY9,5 | -     | 6700   | 2000     |
|   | 3425   | MSD250/2-OS | HSD250/2         | OSRAM   | 250   | 94    | GY9,5 | -     | 6700   | 2000     |
| 7 | 10432  | LHRI100     | LHRI             | OSRAM   | 100   | -     | -     | -     | 9000   | 6000     |
|   | 10165  | L2R         | MSD Platinum 2R  | PHILIPS | 132   | -     | -     | -     | 8000   | 6000     |
|   | 10357  | L5R         | MSD Platinum 5R  | PHILIPS | 189   | -     | -     | -     | 8000   | 2000     |
|   | 10358  | L15R        | MSD Platinum 15R | PHILIPS | 300   | -     | -     | -     | 8000   | 2000     |

### PROJECTION LAMPS

|   | REF  | NAME        | TYPE           | ANSI | BRAND   | WATTS | VOLTS | FOOT  | ANGLE | KELVIN | LIFESPAN |
|---|--|-------------|----------------|------|---------|-------|-------|-------|-------|--------|----------|
| 8 |  9006 | LBVM1       | 64514          | BVM  | CONTEST | 300   | 120   | G6,35 | 3150  | 6300   | 150      |
|   | 1247   | G6,35300110 | 64514          | BVM  | OSRAM   | 300   | 120   | G6,35 | 3400  | 7700   | 75       |
| 9 |  9007 | LBVM3       | 64516          | BVM  | CONTEST | 300   | 240   | G6,35 | 3200  | 7700   | 75       |
|   | 0628   | G6,35300220 | 64516          | BVM  | OSRAM   | 300   | 240   | G6,35 | 3400  | 7300   | 75       |
|   | 0626   | G6,3540036  | 64663 - A1/239 | EVD  | OSRAM   | 400   | 36    | G6,35 | 3400  | 14000  | 100      |

### DICHROIC LAMPS

|    | REF  | NAME      | TYPE           | ANSI | BRAND   | WATTS | VOLTS | FOOT   | ANGLE | KELVIN | LIFESPAN |
|----|--|-----------|----------------|------|---------|-------|-------|--------|-------|--------|----------|
| 10 | 0624   | EFP10012  | 6834 - A1/231  | EFP  | OSRAM   | 100   | 12    | GZ6,35 | -     | 3250   | 50       |
| 11 |  9009 | LEFR      | 6423 - A1/232  | EFR  | CONTEST | 150   | 15    | GZ6,35 | 5000  | 3400   | 50       |
|    |  9008 | LELC      | 13163 - A1/259 | ELC  | CONTEST | 250   | 24    | GX5,3  | 8500  | 3200   | 50       |
| 12 | 3119   | ELC25024  | 13163 - A1/259 | ELC  | OSRAM   | 250   | 24    | GX5,3  | -     | 3400   | 50       |
|    | 8986   | LELC/LD   | ELC5H-         | ELC  | OSRAM   | 250   | 24    | GX5,3  | 8300  | 3100   | 300      |
|    |  0177 | ENH250120 | 13095          | ENH  | OSRAM   | 250   | 120   | GX5,3  | -     | 3250   | 175      |

### STROBOSCOPIC LAMPS

|  | REF  | NAME    | FOOT   | BRAND   | WATTS | KELVIN | LIFESPAN |
|--|--|---------|--------|---------|-------|--------|----------|
|  |  9021 | LST1500 | XOP-15 | CONTEST | 1500  | 5600   | 500      |

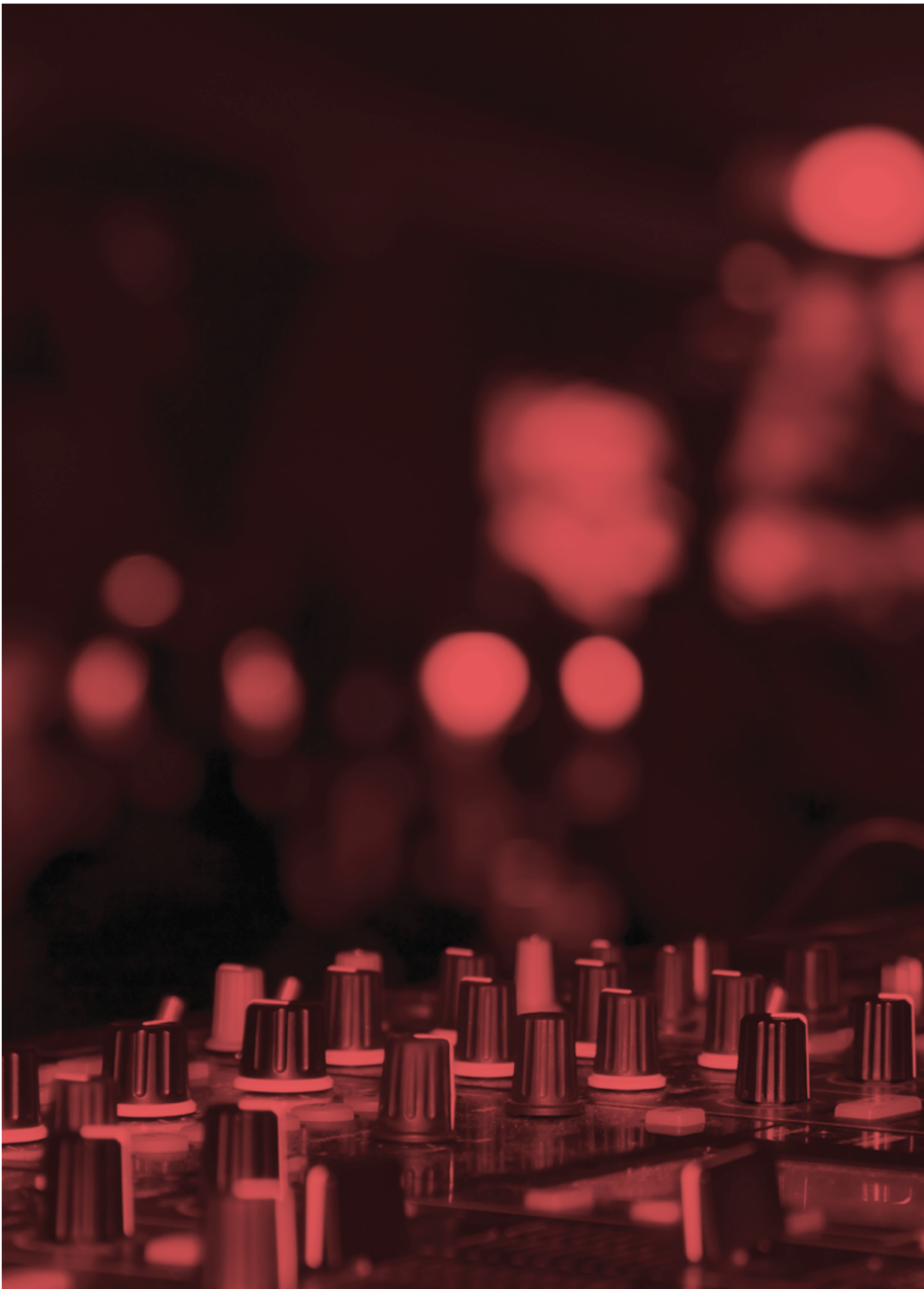



# **MIDI CONTROLLERS AND MULTIMEDIA PLAYERS**

# DJINN PRO

Mixer/USB player/Professional MIDI controller

**Mix analog and digital sources via a single platform. Djinn Pro is the solution**

ref 9932



 Windows  
macOS

## THE DJINN PRO IS AT THE HEART OF YOUR MIX.

No need for any computer as long as you have your music with you: hard disks, USB keys, turntables and CD players.

It can also be used as a MIDI controller compatible with most DJ softwares and is supplied with the famous Virtual DJ LE.

Insert any analog source in your mix, thanks to the Line and microphone inputs.



- + Double USB player with effects, HotCue, etc.
- + Fully compatible with your Midi DJ software
- + Digital mixer with 2 phono/line and 2 micros analog inputs
- + Get the latest version of virtual DJ8 LE for free at [www.virtualdj.com/download](http://www.virtualdj.com/download)
- + Professional sound card ASIO 2.0 and Core Audio compatible



EQ

# DJINN

19" Djinn Pro mounting brackets

ref 9856

# DJAZZ PRO

MIDI/Audio controller for DJ softwares

**Midi controller with a professional sound card**  
**TimeREF and Fx-Thru compatible**

ref 9923



Windows  
macOS

## DJAZZ YOUR MIXES

Connect your Mac or PC computer and play with loops, samples, and a great variety of effects with the DJazz Pro controller.

Versatile, intuitive and performant, compatible with most DJ softwares and supplied with a VIRTUAL DJ LE license, the DJazz Pro is the best tool to enjoy mixing music.



231

- + 4-deck highly comprehensive DJ controller
- + Balanced and unbalanced Master output
- + Headphone output with adjustable volume and CUE/MIX balance
- + Supplied with the 4-deck version of Virtual DJ LE 7
- + Professional sound card ASIO 2.0 and Core Audio compatible



FRONT



REAR

# CDX6

CD / USB MP3 Player - Professional MIDI controller

**Whatever the source, control your mix**

ref 9574

 Windows  
 macOS

- + Extremely advanced loop system
- + CD/USB/MP3 player and MIDI controller
- + Hot Cue, Samples and beat-synchronisable effects

## TECHNICAL SPECIFICATIONS

- Slot-in MP3/CD player
- 2-port USB player for USB keys or hard disks
- MIDI controller via USB (at the rear)
- DSP with Echo, Flanger, Filter, Reverse and Scratch effects
- Large backlit jog wheel with touch detection
- 3 Jog modes : Vinyl, BEND and Cue scratch
- Adjustable pitch : +/-6%, 10%, 16% and 100% with Pitch Bend function
- Master Tempo function
- 4 HOT CUE points and storable samples
- Music-sensitive effects
- Adjustable smart loop
- Auto or manual BPM
- Use the Next track function to save the next track you want to play
- Use a USB link to connect two controllers to the same hard disk
- Large VFD screen
- ID3 visualisation of the artist, title and genre information
- Browse through the folders to find the mp3 file you need
- Use the Xfader playing with compatible mixers
- Digital output
- Dimensions : 296 x 218 x 104 mm
- Weight : 2.4 kg

232



- + Play MP3 files via CD or USB devices
- + Advanced loop management
- + Super efficient design
- + Slot-in reader



# CDX4

CD / USB / MP3 player with various effects

**The super-efficient, DJ-oriented CD and USB player**

ref 9812

## TECHNICAL SPECIFICATIONS

- |  |  |
|--|--|
| USB mass Storage reader for USB keys or hard disks   | Adjustable Pitch: 8/16/100% for MP3 and audio sources  |
| Slot-in reader compatible with Audio CDs and MP3 (on the front side)                               | Master Tone : change the pitch, keep the same tonality |
| ID3 TAG : identify the tracks and artists you are playing  | AVM : 15 seconds Anti Vibration Memory system          |
| Folder : browse through folders to find the track or artist you need                               | Auto-Cue and playlist programming                      |
| New DSP with Echo, Flanger, Filter, Reverse and Scratch effects + adjustable volume and parameters | Multi-functional jog wheel                             |
| SMART LOOP : You can match your loop with the tempo  | Highly visible blue LCD display                        |
| Auto loop: Your loop automatically matches the tempo   | Analogic and digital outputs                           |
|  | Xstart and Relay connections                           |
|  | Dimensions : 220 x 315 x 100 mm                        |
|  | Weight : 2.5 kg  |



# MPU320

Double CD/USB MP3 player

**Easy and quick access to you music with this DJ-designed multimedia player**

ref 9681

## TECHNICAL SPECIFICATIONS

- ..... Double MP3 CD/USB reader with AVM system
- ..... USB player with two USB mass storage inputs (front and rear)
- ..... Reads any USB (FAT32) device regardless their storage capacity and can read both simultaneously
- ..... Pitch:  $\pm 4\%$  to  $\pm 16\%$  ( $\pm 100\%$  for audio CDs)
- ..... Master Tone : change the pitch, keep the same tonality
- ..... Auto and manual BPM, perfect loop, Auto CUE
- ..... Use the knobs to browse through your files and folders
- ..... X-start and Relay functions
- ..... 2 Jog modes (including scratch)
- ..... (-10 dB) RCA unbalanced outputs
- ..... 19" edge-rackable and direct access to the ON/OFF button (front)
- ..... Player dimensions : 482 x 89 x 263 mm
- ..... Controller dimensions : 482 x 91 x 94 mm
- ..... Power supply : 230 V - 50 Hz, AC
- ..... Weight : 5.1 kg (player), 9 kg (controller)

## REMOTE CONTROL FUNCTIONS :

- ..... Source selection (CD, USB1 or USB2)
- ..... Loop functions (IN, OUT and OOP)
- ..... Play/Pause and CUE
- ..... Folder and file selection, you can also search within a track
- ..... Pitch functions: + and - , reset
- ..... Play a single track or a whole directory
- ..... Volume output settings
- ..... CD Eject
- ..... New function repeat (folder/track/all)
- ..... New function random (folder/all)



- + 2 USB ports
- + Unlimited USB storage
- + Instant reaction

233

# MPU310

Professional CD/USB MP3 player  
**Installation multimedia player**

ref 9680

- + CD/USB player MP3 compatible
- + Remote control with pitch, volume and loop control
- + XLR (balanced) RCA (unbalanced) outputs
- + Auto Cue and Auto Pause functions



## TECHNICAL SPECIFICATIONS

- |   |   |  |
|---|---|--|
| <ul style="list-style-type: none"> <li>..... CD/USB, CDA/MP3/Wave player- AVM system</li> <li>..... USB player with two USB mass storage inputs (front and rear)</li> <li>..... Reads any USB (FAT32) device regardless their storage capacity</li> <li>..... Pitch: <math>\pm 4\%</math> to <math>\pm 16\%</math> (<math>\pm 100\%</math> for audio CDs)</li> <li>..... The Master Tone function allows you to modify the speed without any tone alteration</li> </ul> | <ul style="list-style-type: none"> <li>..... Manual and auto BPM, perfect loop, Auto CUE</li> <li>..... Use the knob to browse through your files and folders</li> <li>..... Infrared remote control supplied</li> <li>..... High contrast LCD screen</li> <li>..... (+4 dB) XLR balanced output</li> <li>..... (-10 dB) RCA unbalanced output</li> </ul> | <ul style="list-style-type: none"> <li>..... 19" edge-rackable and direct access to the ON/OFF button (front)</li> <li>..... Player dimensions : 482 x 89 x 270 mm</li> <li>..... Power supply : 230 V - 50 Hz, AC</li> <li>..... Weight : 5.1 kg</li> </ul> |
|---|---|--|

# TT 2930

Turntable

**Music lovers and DJ's, High Torque Motor turntable**

ref 6259

## TECHNICAL SPECIFICATIONS

Linear pitch: from +/-10 % to +/-20%

Speeds: 33/45 and 78 RPM

REVERSE function

Molded ABS housing with a heavy, anti-vibrations base

Shock-absorbent legs

S-shaped tonearm with adjustable height from 0 - 6 mm

Adjustable counterweight: from 0 - 4 g

Adjustable antiskating: from 0 - 7

RCA outputs

Strobe: 675 Hz at 33 RPM

Phone/Line outputs volume control

Electronic braking system

High-torque motor

Dimensions : 450 x 352 x 157 mm

Weight : 11 kg

Supplied with :

- Audio-technica® cartridge

- AUDIOPHONY® slip mat

- Dust cover

## YOUR DAY-TO-DAY TURNTABLE

A High Torque Drive for a perfect rotation at variable speeds (33,45 or 78 RPM). Many intuitive commands and high-quality materials make it perfect for professionals and music-lovers.

It also features a phono/line output to plug it to your HiFi system or mixing desk. You can protect your TT-2930 from transport damage with the removable dust cover.

- + High-torque direct-drive motor and electronic braking system
- + 45/33/78 RPM Turntable with a removable dust cover
- + -20% to +20% Adjustable pitch and Reverse function
- + Switchable Phono or Line output



234

## ACCESSORIES



### S-15

Audio-Technica® cartridge with stylus  
ref 4369

### HEADSHELL/NO

Headshell for a black turntable  
ref 4373



### CENTREUR 45T

45 RPM aluminium adapter for turntables  
ref Z03008

### STYLUS-15

Replacement stylus for a S-15  
Audio-technica®  
ref 4371



# BDA-100

Active Direct Box

**Transport your signal over long distances thanks to this self-powered DI unit**

ref 7678



# CONVERTER

USB/PHONO/LINE Converter

**Simply digitalise your vinyls**

ref 9077



**IT HAS NEVER BEEN SO EASY:**

Create your own audio files with Audacity®, a free audio editor and recorder available in many languages.

- + 2 inputs/2 outputs simultaneously
- + Line and phono stereo input
- + Adjustable input level with LED display



## TECHNICAL SPECIFICATIONS

- 1 Jack 6.35 unbalanced input
- 1 XLR balanced output
- 1 XLR output
- Max input volume level : 0/+20/+40 dB
- Dimensions : 135 x 55 x 130 mm
- Weight : 0.700 kg
- 9 V battery not supplied

## TECHNICAL SPECIFICATIONS

- Complete and efficient tools to optimise your audio recordings
- Record your vinyls at an accelerated speed
- Ergonomic interface
- No drivers required, you just need to plug it to start working with most of the audio softwares
- 1 RCA line/phono stereo output using the selector, 1 RCA stereo line output
- Cable length : 1.5 m

# AD-BOX

Analogic to Digital USB converter

**Digitalize your sources in the blink of an eye**

ref 9268



- + Audacity compatible (free)
- + Crystal-clear sound, without disturbances
- + Compatible with Mac OS, Windows and Linux without additional drivers



## TECHNICAL SPECIFICATIONS

- Compatible with Mac OS, Windows and Linux without additional drivers
- AD~DA 16 bits / 48 kHz converter
- 1 input / 1 output
- Combo input connector
- RCA output
- USB-powered



# GAMME BLUETOOTH® HD

Et tout devient sans fil...\*

\*When everything goes wireless...



## BT10ER

Émetteur/récepteur audio  
Bluetooth® sur batterie



## BT20R

Récepteur Bluetooth® /  
Chargeur USB 5V



## BT2xE

Double émetteur audio  
stéréo Bluetooth®



by  **audiophony**  
EQUIPMENTS



# BT10ER

Battery-operated Bluetooth audio transmitter/receiver

**Compact, light and easy to use. Bring the BT10ER everywhere you go**

ref 10015



The BT10ER is a simple and efficient battery-operated receiver or transmitter: it converts any source in a Bluetooth® device. It is fully compatible with any other Bluetooth® device and will please professionals and casual music lovers.

Use to Micro USB input to charge the battery (cable supplied)

Mini jack 3.5 stereo input/output

- + An astonishing Bluetooth® stereo sound quality
- + Ultra-low encoding latency. Reduced latency and lip-synch problems
- + Switch from Emission to Transmission in a flash
- + Mini jack 3.5 audio connector

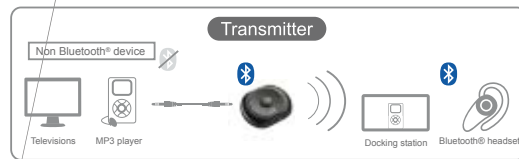
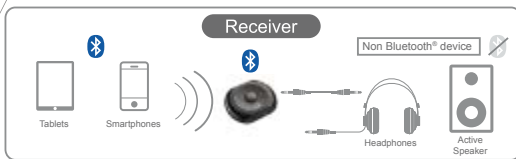

## CODECS COMPARATIVE TABLE BLUETOOTH®

| TECHNICAL SPECIFICATIONS      |                       | BT2xE                              | BT20R                              | BT10ER                             |
|-------------------------------|-----------------------|------------------------------------|------------------------------------|------------------------------------|
| Bluetooth                     |                       | 4.1                                | 4.0                                | 2.0                                |
| Supported Bluetooth® profiles |                       | A2DP                               | A2DP and AVRCP                     | A2DP and AVRCP                     |
| Audio codec                   |                       |                                    |                                    |                                    |
| Codec                         | SBC                   | Yes                                | Yes                                | Yes                                |
|                               | aptX                  | Yes                                | Yes                                | Yes                                |
|                               | aptX-LL (Low Latency) | Yes                                | -                                  | -                                  |
| Operating range               |                       | 10 m average - Class 2             |                                    |                                    |
| Power supply                  | Battery               | Yes ( 8 hours approximately )      | -                                  | Yes ( 10 hours approximately )     |
|                               | Main / USB            | Yes                                | Yes                                | Yes                                |
| Weight                        |                       | 30 g                               | 51 g                               | 48,5 g                             |
| Accessories                   |                       | Jack 3.5mm and RCA cables supplied | Jack 3.5mm and RCA cables supplied | Jack 3.5mm and RCA cables supplied |

# BT2xE

Dual audio/stereo Bluetooth transmitter  
 ref 10413

BT2xE is a very easy-to-use, light and compact dual Bluetooth audio transmitter. It can be used in permanent installations and powered up via its USB port, but can also be used via its built-in battery. The next-generation "aptX-LL" codec offers a close-to-zero latency and perfect audio/video synchronization. Its compact format and magnetic base allows a discrete integration to your installation, and simplified use. It comes with its USB cable and audio adapters to connect to any kind of equipment. Our advice: this is the ideal solution to send an audio signal to a pair of amplified speakers with Bluetooth receivers.

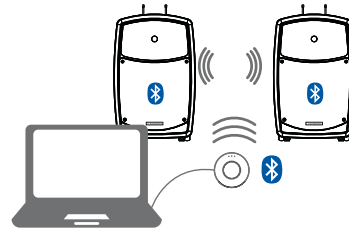

- + Incredible stereo Bluetooth® sound quality
- + Allows you to share your audio signal with 2 Bluetooth® sources
- + Use its adhesive base to install it

238



Share your audio source with  
 2 Bluetooth devices instantly

| TECHNICAL SPECIFICATIONS      |                       | BT2xE                              |
|-------------------------------|-----------------------|------------------------------------|
| Bluetooth                     |                       | 4.1                                |
| Supported Bluetooth® profiles |                       | A2DP                               |
| Audio codec                   |                       |                                    |
| Codec                         | SBC                   | Yes                                |
|                               | aptX                  | Yes                                |
|                               | aptX-LL (Low Latency) | Yes                                |
| Operating range               |                       | 10 m average - Class 2             |
| Power supply                  | Battery               | Yes ( 8 hours approximately )      |
|                               | Main / USB            | Yes                                |
| Weight                        |                       | 30 g                               |
| Accessories                   |                       | Jack 3.5mm and RCA cables supplied |

# BT-20R

Bluetooth® USB 5V receiver/charger  
 ref 10305

## SHARE YOUR BLUETOOTH® DEVICE MUSIC WITH YOUR HIFI SOUND SYSTEM

The BT20R features a USB port allowing you to charge your device while using it.

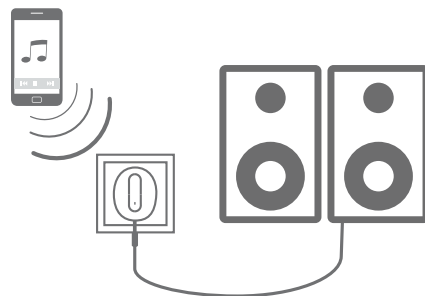

| TECHNICAL SPECIFICATIONS      |                       | BT20R                              |
|-------------------------------|-----------------------|------------------------------------|
| Bluetooth                     |                       | 4.0                                |
| Supported Bluetooth® profiles |                       | A2DP and AVRCP                     |
| Audio codec                   |                       |                                    |
| Codec                         | SBC                   | Yes                                |
|                               | aptX                  | Yes                                |
|                               | aptX-LL (Low Latency) | -                                  |
| Operating range               |                       | 10 m average - Class 2             |
| Power supply                  | Battery               | -                                  |
|                               | Main / USB            | Yes                                |
| Weight                        |                       | 51 g                               |
| Accessories                   |                       | Jack 3.5mm and RCA cables supplied |



# HEADPHONES





# YBT-100G

High-rendering Bluetooth® earphones  
ref 10303

The Bluetooth® YBT-100G and YBT-100S earphones are ultra-light, high sound quality devices. They are your daily, loyal friends and will follow you everywhere you go, whatever you do. The EARS-FIT system allows them to easily resist to any kind of movement.

- Compatible with any Bluetooth® device
- COMPATIBLE WITH THE FOLLOWING BLUETOOTH® PROTOCOLS : V4.0 CSR HFP, A2DP, AVRCP
- Vocal help messages
- Bluetooth® range : Up to 10 metres - Class 2, 4.0 Bluetooth®
- Average battery life : 8 hours when playing music / 6 with vocal conversations  
150 hours when on hold
- Charge time : approximately 2 hours
- Tightness level : IPX5 (sweatproof and rainproof)
- Battery: Lithium 85mAh
- Output level : 100dB max.
- Frequency response : 20Hz-20KHz
- S/N ratio : >70dB
- Distorsion : <0.1%



The indicator turns blue when the battery is fully charged.



- + "EARS-FIT" system
- + Remote Control
- + Only 14 grams
- + Supplied with a pouch bag
- + Sweat and water-resistant: ideal for sports.

# YBT-100S

High-rendering Bluetooth® earphones  
ref 10304

- Compatible with any Bluetooth® device
- COMPATIBLE WITH THE FOLLOWING BLUETOOTH® PROTOCOLS : V4.0 CSR HFP, A2DP, AVRCP
- Vocal help messages
- Bluetooth® range : Up to 10 metres - Class 2, 4.0 Bluetooth®
- Average battery life : 8 hours when playing music / 6 with vocal conversations  
150 hours when on hold
- Charge time : approximately 2 hours
- Tightness level : IPX5 (sweatproof and rainproof)
- Battery: Lithium 85mAh
- Output level : 100dB max.
- Frequency response : 20Hz-20KHz
- S/N ratio : >70dB
- Distorsion : <0.1%

Supplied with a lot of accessories :  
1 x USB charging cable  
1 x Pouch bag  
3 x Silicone Earplugs "ears-fit"  
3 x earplugs S,M,L size



- + "EARS-FIT" system
- + Remote Control
- + Only 14 grams
- + Supplied with a pouch bag
- + Sweat and water-resistant: ideal for sports.

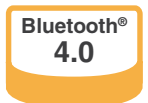

NFC-compatible

# Bluetooth® Headphones



# BT2i

Top-of-the-range Bluetooth® headphones

**Always by your side**

ref 10079



These top-of-the-range headphones can be plugged with a cable or connected to any Bluetooth® audio device. Being in a noisy environment does not matter at all since the BT2i benefits from an incredible sound isolation, providing a pure sound and an unmatched comfort.

Designed with deep basses, highly detailed trebles and pure medium frequencies, you will love its high-sound quality and use it tirelessly for hours.



- + Noise-cancelling and optimal comfort
- + Battery life of approximately 13 hours
- + Hands-free kit function



242

## YOU WILL NEVER GET TIRED OF IT

The BT2i features a built-in, almost invisible but super-efficient microphone. You can now make phone calls via your smartphone, computer or any other Bluetooth® device. Source may change, sound quality doesn't.



## TECHNICAL SPECIFICATIONS

Battery life: approximately 10 - 13 hours

Charge time: approximately 2 hours

Lithium battery: 3,7 V 400 mA

Bluetooth® V 2.1 CSR, A2DP, AVRCP

Hands-free communication via the built-in microphone

Wireless range: approximately 10 meters  
Class 2 Bluetooth®

Loudspeaker: 40 mm - 32 Ohms 20 mW

Transducer principle : Dynamic

Frequency response: 20 Hz-20 kHz

Max output level: 100 dB

Weight 150 g

Other features included :

- A carry pouch

- A USB power cord

- A minijack/minijack cable for a wired usage

- Airplane headphones dual-prong jack adapter

\*The Bluetooth® audio chat and phone calls functions require Bluetooth® compatible devices.

\*\* The Bluetooth® trademark and logo are registered by the Bluetooth SIG, inc.

# YC100

Fully-enclosed headphones  
**Over hear headphones**  
ref 10129

These lightweight headphones offer a crystal-clear sound across all frequencies, an excellent background noises isolation, saying that they are perfect for a daily use. Moreover, they are extremely efficient when it comes to mixing thanks to their 180° swivelling ear cups.

Fold them, pack them, take them everywhere you go.



- + Over hear, noise-cancelling headphones
- + Light and ergonomic
- + Intense and massive basses



## TECHNICAL SPECIFICATIONS

|  |                                     |   |
|--|-------------------------------------|---|
| Transducer principle : Dynamic, closed | Sensitivity : 100 dB +/-3 dB        | Cable : ø4mm x 2.2 m                                  |
| Loudspeaker : 50 mm                    | Max power : 1000 mW                 | Connectors : ø3.5 mm, supplied with a 6.35 mm adapter |
| Impedance : 60 Ω                       | Frequency response : 10 Hz - 20 kHz | Weight : 310 g  |

# DJ-950

Close up DJ headphones

**The DJs' choice**

ref 8222

## « KEEP THE RYTHM GOING »

These headphones are the perfect example of DJ-focused headphones. They are light, they are comfortable and they offer a high sound accuracy and bass rendering. The one single cable, combined to the rotating ear cups allow you to mix without any technical restraint. More, you can change the ear pads with the included velvet models.

### TECHNICAL SPECIFICATIONS

|  |
|--|
| Loudspeaker : 57 mm  |
| Impedance : 64 $\Omega$  |
| Sensitivity : 113 dB   |
| Max power output : 3.5 W   |
| Frequency response : 5 - 30 kHz                                      |
| Cable : 4 m with a Jack 3.5 / 6.35 adapter and an elbow 6.35 adapter |
| Carrying bag and extra ear pads supplied                             |



244

# DJ-930

Semi-open on-ear dynamic headphones

**The flexible choice**

ref 8223

- + Pristine and powerful output
- + Light and comfortable
- + Supplied with a carrying bag
- + Rotating ear cups

### TECHNICAL SPECIFICATIONS

|  |
|--|
| Loudspeaker : 57 mm                        |
| Impedance : 64 $\Omega$                    |
| Sensitivity : 107 dB                       |
| Max power output : 3.5 W                   |
| Frequency response : 30 - 18 kHz           |
| Cable : 4 m with a Jack 3,5 / 6,35 adapter |
| Carry pouch supplied                       |







# MICROPHONES



# UHF410 BASE RECEP UHF

UHF True Diversity receiver with auto scan function and transport case  
ref 10271



## TECHNICAL SPECIFICATIONS

|  |   |   |
|--|---|---|
| True Diversity receiver                                      | Line or Mic level                             | Adjust the Squelch setting with the rear control knob                       |
| Frequency range : UHF 863 ~ 865 MHz                          | Oscillator : PLL Synthesiser                  | BNC removable antennas, many accessories available                          |
| 40 preset frequencies with Auto-scan function                | Frequency stability : $\pm 0,005\%$           | Power supply : 12 V DC (adapter supplied)                                   |
| Channels presets : 4 groups, 4 compatible channels per group | Modulation : FM                               | Power consumption : 260mA $\pm$ 10mA  |
| Channels selection : Tact Switch, Auto-Scan, SYNC            | T.H.D. : <1% (@1KHz)                          | Dimensions : 200 x 42 x 183 mm (Mountable by groups of 2 in 19" wide racks) |
| LCD Display : frequency, group, canal, RF & AF               | Audio frequency response : 80 Hz at 18kHz     | Dimensions: 200 x 42 x 183 mm (19" mount rackable by pair)                  |
| XLR and Jack6.35 mono balanced and unbalanced audio output   | Adjust the volume with the front control knob |   |

## UHF410HAND

Handheld electret UHF microphone  
ref 10272



## TECHNICAL SPECIFICATIONS

|  |
|--|
| True Diversity emitter                             |
| Frequency range : UHF 863 ~ 865 MHz                |
| Power output : 10mW (max.)                         |
| 40 preset frequencies with SYNC function           |
| LCD display : channel, batterie level              |
| Power supply : 2 AA 1.5 V batteries (not supplied) |
| Average battery life: 10 hours                     |
| Dimensions : 260 x 54 mm diam                      |

## UHF410BODY

Bodypack True Diversity emitter  
ref 10273

BODYPOCKET compatible

## TECHNICAL SPECIFICATIONS

|   |
|---|
| True Diversity emitter                                    |
| Frequency ranges : UHF 863 ~ 865 MHz                      |
| Power output : 10mW (max.)                                |
| 40 channels with Auto-scan function                       |
| LCD display : channel, batterie level                     |
| Mic input via mini XLR                                    |
| Gain level: -10/0/+10 dB                                  |
| Power supply : 2x AA type 1,5V V batteries (not-supplied) |
| Battery life: 10 Hours                                    |
| Dimensions : 98 x 65 x 25 mm (+ 75mm with the antenna)    |



246



## PACK UHF410 HAND

Set including a UHF True Diversity receiver and a handheld microphone in its transport case  
ref 10282

## PACK UHF410 HEAD

Set including a UHF True Diversity receiver + a bodypack and a headband microphone in their transport case  
ref 10283

## PACK UHF410 LAVA

Set including a UHF True Diversity receiver + a bodypack and a Lavalier microphone in their transport case  
ref 10284

## UHF410**HEAD**

Sweat-proof headband electret microphone - mini XLR  
ref 10274



### TECHNICAL SPECIFICATIONS

Micro type : Electret condenser  
Sensitivity :  $-47 \pm 4$ dB  
Directivity : Cardioid  
Frequency response : 100Hz - 10KHz  
Max current: 10V  
Standard current : 1.5V  
Power consumption : 0.5mA max.  
S/N ratio : More than 60dB  
Supplied accessory : Windshield  
Connector : Mini XLR

## UHF410**LAVA**

Lavalier microphone - mini XLR  
ref 10275



### TECHNICAL SPECIFICATIONS

Sensitivity :  $-67 \pm 3$ dB  
Directivity : Omnidirectional  
Frequency response : 50Hz à 10 KHz  
Max current: 10V  
Standard current : 1.5V  
Power consumption : 0.5mA max.  
S/N ratio : More than 58dB  
Supplied accessory : Windshield and clip  
Connector : Mini XLR  
Dimensions : 37 x 5.5 mm diam

## UHF410**BOOST**

Booster antenna with a BNC connector  
ref 10276



### TECHNICAL SPECIFICATIONS

Booster antenna with a BNC connector  
- Frequency range : 550 ~ 950 MHz  
- Gain : 9 dB +/- 1 dB  
- Impedance : 50 Ohms  
- Power supply : 8 V, DC

## UHF410**HOLD**

Antenna mount with BNC connector  
ref 10277

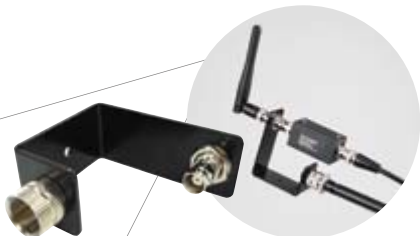

### TECHNICAL SPECIFICATIONS

5/8 Thread Screw Adaptor Mic Stand + BNC male

## UHF410**SPLIT**

2-in-1 IN/OUT Line splitter with BNC connector  
ref 10278



### TECHNICAL SPECIFICATIONS

Frequency range: 400 ~ 1000 MHz  
VSWR: <2  
Input impedance : 50 Ohms  
Isolation: 10dB  
Losses: <3 dB  
Connectors: BNC  
Dimensions: 77 x 64 x 26 mm

## UHF410**ANT**

Long range directional antenna + BNC connector  
ref 10279



### TECHNICAL SPECIFICATIONS

Frequency range : 500 ~ 950 MHz  
Beamwidth : 80° E-plane, 140° H-plane  
Impedance : 50 Ohms  
Connector : BNC  
Dimensions : 295 x 210 x 31 mm

## UHF410 **RALL10M**

BNC/BNC Antenna 10 m extension cable  
ref 10281



## UHF410 **RALL1M**

BNC/BNC Antenna 1m extension cable  
ref 10280

## UHF410-**BNC1**

BNC/BNC connector for extension cable  
ref 10641



## UHF410-**BNC2**

BNC/BNC connector for bracket  
ref 10639



## UHF410-**RACK**

Long bracket for receptor  
ref 10640



# GO SERIES

The GO series features the latest technologic evolutions and an optimal transmission quality. It meets the European standards and uses a wide frequency range allowing you to use up to 4 systems simultaneously.

## TECHNICAL SPECIFICATIONS

**Receivers:** 16 UHF frequencies UHF Frequency range : 863-865 MHz Diversity system: protection against micro-cuts Adjustable squelch to absorb disturbances Use up to 4 receivers simultaneously (4 microphones) Adjustable antenna (front) • Average range of 70m (with optimal conditions) • XLR balanced output and balanced Jack output. Use the FREE-RACK (optional) to rack them in pair  
Dimensions : 130 x 36 x 92 mm Power supply : 12 V, DC with a supplied adapter

**Transmitters:** 16 UHF frequencies Frequency range UHF : 863-865 MHz Average range of 70m (with optimal conditions) Max power output : 10 mW

## GO-BODY

Bodypack transmitter for tie-clip or headband microphones

ref 9990

BODYPOCKET compatible

## GO-MONO

UHF 16 frequencies diversity receiver for 1 transmitter

ref 9988

### TECHNICAL SPECIFICATIONS

Emission only

Must be combined with a tie-clip or headband GO series microphone and a GO-MONO receiver

Mini XLR input

2 impedance modes: line or micro

Operates with 2x1.5V type AA batteries

Dimensions : 65 x 100 x 27 mm



### TECHNICAL SPECIFICATIONS

Reception only

Must be combined with a Go series UHF transmitter

248



## PACK GO HAND

1 GO Mono receiver • 1 GO Hand handheld transmitter

ref 9999

## PACK GO HEAD

1 GO Mono receiver • 1 GO Body bodypack transmitter

• 1 headband GO Head microphone

ref 10001

## PACK GO LAVA

1 GO Mono receiver • 1 GO Body bodypack transmitter

• 1 GO Lava Lavalier microphone

ref 10000



## GO-HEAD

Headband electret microphone – mini XLR  
ref 9991



### TECHNICAL SPECIFICATIONS

Headband microphone only. Must be combined with a GO-BODY transmitter and a GO-MONO receiver  
Mini XLR connector  
Supplied with a microphone windshield and an adjustable headband  
Unidirectional electret  
Frequency response : 100 Hz at 16 kHz  
S/N : > 60 dB  
Impedance : 2.2 kOhms

## GO-LAVA

Lavalier microphone – mini XLR  
ref 9992



### TECHNICAL SPECIFICATIONS

Tie-clip microphone only  
Must be combined with a GO-BODY transmitter and a GO-MONO receiver  
Mini XLR connector  
Supplied with a microphone windshield and a tie clip  
Unidirectional electret  
Frequency response : 100 Hz at 16 kHz  
S/N : > 60 dB  
Impedance : 2.2 kOhms

## GO-HAND

Handheld electret UHF microphone  
ref 9989



### TECHNICAL SPECIFICATIONS

Handheld microphone only  
Must be combined with a GO-MONO receiver  
High-quality unidirectional electret  
Distortion rate: less than 1% at 1kHz  
Operates with 2 1.5V type AA batteries  
Dimensions : 237 x 58 mm

## FREE-RACK

19" Mounting bracket for 2 receivers  
ref 9374



### TECHNICAL SPECIFICATIONS

Material: Steel  
Finishing: Black

## BODYPOCKET

Neoprene belt for UHF transmitters  
ref 10484

- + Compatible with Audiophony® transmitters
- + GOBody
- + UHF410-Body



# WAVE

Handheld VHF microphone

**VHF, affordable and performant microphone**

WAVE-F1 / 177.5 MHz  
Ref 9549

WAVE-F2 / 185.3 MHz  
Ref 9550

The Wave was designed to give your voice the accurate amplification it deserves. Its extended battery life and incredible range are ideal for your animations or speeches. Its high-quality cell perfectly replicates your tone of voice and intonation. 2 frequencies are available: 177.5 MHz VHF and 185.3 Mhz VHF.

- + Battery life of almost 8 hours
- + Dynamic handheld microphone
- + Frequency range: up to 50 m
- + 2 frequencies available

250



## TECHNICAL SPECIFICATIONS

### RECEIVER :

Three LEDs indicate the ON/OFF status, the reception quality and the signal detection.

Adjust the output volume via the volume knob to avoid signal saturations.

Unbalanced jack 6.35 output (jack/jack cable supplied)

Power supply via the supplied adapter : 9 V 300 mA, DC

### MICROPHONE :

Cardioid dynamic microphone

ABS housing and steel mesh grille

OFF/Mute/ON switch

Pop filter

Frequency response : 40 at 13 kHz

S/N ratio : 80 dB

Range: up to 50 meters (with optimal conditions)

Operates with a 9 V (6 LR-61) battery



# RP1

Cardioid dynamic microphone

**Taking its place among the very best**

ref 9654

- + Designed for live singing performances
- + Powerful, crystal-clear output
- + Very resistant metal housing
- + Supplied with a pouch bag and a clip

We put so much efforts into the RP1 that we created a microphone beyond all our expectations.

Its unidirectional membrane was handpicked among hundreds for its dynamism and source fidelity. Designed for singers, it will transcend your voice on any stage.

## TECHNICAL SPECIFICATIONS

|   |
|---|
| Use : Vocals  |
| Type : Dynamic cardioid microphone  |
| Materials and features : Aluminium housing, steel mesh grille, shock-proof and pop filter |
| Connector : XLR   |
| Impedance : 600 $\Omega$ +/-30% at 1 kHz  |
| Frequency response : 70 Hz - 15 kHz   |
| Sensitivity : -53 dB +/-3 dB  |
| Weight : 360 g  |
| Dimensions : 180 x 53 mm  |

# RS1

Dynamic cardioid microphone

**Outstanding in any case**

ref 9653

The RS1 is a very versatile and intuitive microphone, giving its best in any situation. Its membrane was built to absorb the movements and hands noises while its aluminium housing and steel grille make it perfect for stages.

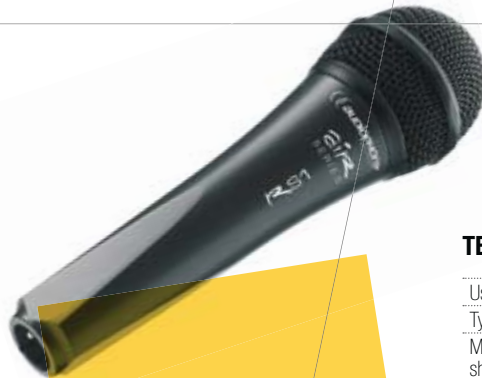

airSERIES

- + Very resistant
- + Movement interferences canceller
- + Supplied with a pouch bag and a clip

## TECHNICAL SPECIFICATIONS

|   |
|---|
| Use : Vocal   |
| Type : Dynamic cardioid microphone  |
| Materials and features : Aluminium housing, steel mesh grille, shock-proof and pop filter |
| Connector : XLR   |
| Impedance : 600 $\Omega$ +/-30% at 1 kHz  |
| Frequency response : 40 Hz - 16 kHz   |
| Sensitivity : -52 dB +/-3 dB  |
| Weight : 355 g  |
| Dimensions : 185 x 50 mm  |

251

## TECHNICAL SPECIFICATIONS

|   |
|---|
| Use : Dynamic mic ideal for animations and speeches             |
| - ON/OFF power switch   |
| - Pop filter  |
| - Shock-absorbent cell  |
| Type : Dynamic, unidirectional                                  |
| Finishing : Aluminium housing, steel mesh grille and Pop filter |
| Connectors : XLR, 6m XLR/JACK cable supplied                    |
| Impedance : 500 $\Omega$ +/-30% à 1 kHz                         |
| Frequency response : 80 Hz - 15 kHz                             |
| Sensitivity : 54 dB +/-3 dB                                     |
| Weight : 360 g  |
| Dimensions : 175 x 53 mm  |



# DMC-62

Dynamic microphone with power switch

**High-quality wired microphone**

ref 9652

# MIXERS





# DIGITAL-3

Compact DJ mixer

**A compact analog/digital 4-band DJ mixer with a dual USB sound card**

ref 9254



- + 4 channels simultaneously including 1 Mic with talkover
- + 2 USB inputs/outputs to play files from a computer
- + Split/Mix headphones mode



## TECHNICAL SPECIFICATIONS

- 2 USB ports (channel 1 and 3) allowing you to play and record audio files
- 3 RCA phono outputs
- 3 RCA line outputs
- 3-band equalizer for each channel
- 2-band equalizer for the microphone

- Gain control for each channel
- High power Master output
- 2 USB ports to connect it to a PC/MAC. The USB plugs are automatically detected by the computer as sound cards without installing any driver
- ON/OFF power switch

- The master output features a LED view meter
- Talk-over, ON/OFF microphone functions
- Very low sound leakage crossfader
- Separate power supply : 9 V / 1000 mA, AC
- Dimensions : 254 x 308 x 82,5 mm
- Weight : 3.4 kg

## THE DIGITAL SERIES MIXERS FEATURES A USB PORT COMPATIBLE WITH MAC AND PC



# DIGITAL-2

DJ compact mixer

**Analog/digital mixer perfect for any professional, no matter your style**

ref 8682

253



- + Use the 3 inputs simultaneously (including 1 Mic input)
- + 2 USB inputs/outputs to play files from a computer
- + Split/Mix function

## TECHNICAL SPECIFICATIONS

- 2 USB-A ports allowing a «Full Duplex» connection to PC and Mac
- A switch allows you to select 2 phono inputs
- A switch allows you to select 2 line inputs
- 1 DJ mic input with automatic TALKOVER at -10 dB

- RCA Master unbalanced output
- The DJ Mic channel features LF/HF -12/+12 dB volume control knobs
- The stereo channels feature LF/HF -15/+15 dB volume control knobs

- Side Headphones output with volume control and Mix/Split function
- 10 LEDs view meters
- Dimensions : 178 x 270 x 85 mm
- Weight : 1.9 kg

# MX SERIES

Mixers



The MX series mixers features a usb port compatible with Mac and PC.

## TECHNICAL SPECIFICATIONS

### CONTROLLERS

Gain control with a peak level indicator, High-pass filter switch, 3-band equalizer, Aux level, Aux pre/post switch (MX1224 and MX1624 only), Effects controllers, Panoramic or balance effects, mute and PFL switch (for MX1224 and MX1624), use the MX822 control knobs and MX1224 / MX1624 faders to adjust the volume settings

Master volume control

Effects and Aux return knob controllers

Headphone input level controllers

ON/OFF power supply switch

Effects selector : 10x24 bits digital effects

### INPUT CONNECTORS

XLR Chassis, Balanced jack 6.35 stereo and jack 6.35 stereo for the mono inputs

XLR or RCA chassis and dual jack 6.35 mono for the stereo inputs

AUX Return via dual jack 6.35 mono

Tape/CD via a RCA chassis

### OUTPUT CONNECTORS

Master and Control Room via 2 Jack 6.35 mono outputs

RCA Record output

Headphone, AUX Send and DSP Send outputs via Jack 6.35 stereo

Footswitch via jack 6.35 mono ( DSP activation)

### TECHNICAL SPECIFICATIONS

Max volume output : 22 dBm

Frequency response (-1dB) : 20 Hz - 20 KHz

T.H.D : < 0,01%

Cross talk : > 70 dB

Hum and S/N ratio:

EIN : > 127 dB - Residual : > 100 dB - Master and AUX outputs : > 80 dB

Equalization : High : +/- 15 dB @ 12 kHz - Mid : +/- 12dB @ 2,5 kHz - Low : +/- 15 dB @ 80 Hz

DSP : 24 bits - 10 presets

Digital input/output : Audio USB 1.1 - 44.1/48kHz - 16 bits - Type B

# MX1624

Compact mixer with digital effects

**10 XLR inputs, numerous effects; a USB port: the MX1624 was built for Live and Studio performances**

ref 9560

- + 10 Mic inputs and 12 bands simultaneously
- + Built-in effects adjustable for each band
- + 2 Aux outputs (including EFX)
- + 1 USB input/output for lossless recordings
- + All the inputs/outputs you need via XLR sockets

254

## TECHNICAL SPECIFICATIONS

Channels : 8 mono / 4 stereo

10 Mic inputs

24-bit DSP with 10 presets

USB-B digital audio input/output

Power supply : External :

- Primary : 230 V - 50 Hz

- Secondary : 17 V x 2 - 1000 mA, AC

Net weight: 5.6 kg

Dimensions (without the 19" mounting brackets)

436 x 420 x 65 mm

19" mounting brackets supplied



# MX1224

Compact mixing desk with many effects

**The MX1224 is a mid-range MX series product, featuring 6 XLR mic inputs, a 24-bit multi-effects and a USB port**

ref 9559

- + 6 Mic inputs and 8 channels simultaneously
- + Built-in effects adjustable for each channel
- + Many XLR outputs and connectors
- + 1 USB input/output to record with quality lossless



## TECHNICAL SPECIFICATIONS

8 bands simultaneously :

- 4 mono bands with insert
- 2 mono/stereo bands (micro/line)
- 2 stereo line bands (jack and RCA)

Balanced inputs/outputs

24-bit digital multi-effects

Footswitch input for EFX

2 Aux Send (including Efx)

Main, ControlRoom, Record outputs

Alt3/4 output (Group 3-4)

Power supply : External

- Primary: 230 V - 50 Hz

- Secondary : 17 V x 2 - 1000 mA, AC

Net weight: 3.4 kg

Dimensions (Without the 19" mounting brackets)

328 x 420 x 65 mm

19" mounting brackets supplied

# MX822

Compact mixing desk with many effects

**Do not let its size fool you: This is a real live performer !**

ref 9558



- + 5 band simultaneously
- + 1 USB input/output for lossless recordings
- + Built-in effects adjustable for each band
- + 2 Aux outputs (including EFX)
- + All the inputs/outputs you need via XLR sockets

## TECHNICAL SPECIFICATIONS

5 bands simultaneously :

- 2 mono bands with insert
- 2 mono/stereo bands (micro/line)
- 1 stereo line bands (jack and CA)

Balanced inputs/outputs

24-bit digital multi-effects

Footswitch input for EFX

2 Aux Send (including Efx)

Main, ControlRoom, Record outputs

Light and compact

Power supply : External

- Primary: 230 V - 25 W

- Secondary : 18 V x 2 - 400 mA, AC

Net weight: 2.8 kg

Dimensions : 247 x 290 x 65 mm



# SUBMIX

Analog/digital mixer with an active filter

**This 6-channel mixer allows you to independently control your subwoofer**

ref 9573

## THE SUBMIX IS A PERFECT TOOL TO OVERCOME FIELD CONSTRAINTS

Well thought-out layout : It features a rear terminal with multiple outputs and removable faders

High fidelity rendering : The components have been selected for their response time and reliability

Beautiful design : A high-quality finishing and materials with pleasant colours make the difference



- + Adjustable active filter for basses settings
- + 1 USB input/output to play files from a computer
- + 15 inputs and 2 outputs
- + Mountable in 19" wide racks

# MYA8C

Club-oriented mixer

**The all-in-one club mixer**

ref 9880

# MYA5D

DJ mixer

**A complete DJ mixer**

ref 9879



REAR

- + Versatile and intuitive
- + Crystal-clear output
- + A real USB sound card



- + Mix 4 decks simultaneously
- + Compact and ergonomic
- + USB sound card without any driver



REAR

256

## TECHNICAL SPECIFICATIONS

### INPUTS

- The channel 6 features a USB port allowing you to play and record via a computer
- 2 Phono via RCA
- 7 Line via RCA
- 2-Micro sockets (front)
- 1 Micro via Jack (rear)
- 1 Mini jack auxiliary input (front)

### CONTROLLERS

- 3-band equalizer for each stereo channel
- 3-band equalizer for each Mic channel
- Gain control for each channel

### OUTPUTS

- Master A balanced and unbalanced output
- Master B unbalanced output
- Record output
- Jack 6.35 stereo monitoring output
- 1 USB Audio port to connect to a computer

### MAIN CHARACTERISTICS

- The mixer is automatically detected by computers (via the usb cable) as a sound card, without any driver
- LED view meter for the Master output and each Line/Phono channel
- ON/OFF switches for each microphone channel
- The DJ channel features a Talk-over function and threshold/mitigation settings
- Very low current leakage crossfader for channels 4 and 5
- Power supply : AC 230V ~ 50Hz
- Power consumption : 25 W
- Dimensions : 483 x 264 x 104 mm (mounting depth :85 mm)
- Weight : 4.5 kg

## TECHNICAL SPECIFICATIONS

### INPUTS

- 1 USB port allowing you to play and record via a computer
- 2 Phono via RCA
- 4 Line via RCA
- 1 Mic via a combo connector (front)
- 1 Mic via a jack connector (rear)

### CONTROLLERS

- 3-band equalizer for each stereo channel
- 3-band equalizer for each Mic channel
- Gain control for each channel

### OUTPUTS

- Master A balanced and unbalanced output
- Master B unbalanced output
- Record output
- Jack 6.35 stereo monitoring output
- 1 USB Audio port to connect to a computer

### MAIN CHARACTERISTICS

- The mixer is automatically detected by computers (via the usb cable) as a sound card, without any driver
- The Master output and each Line/Phono channel feature their own LED view meter
- ON/OFF switches for each microphone channel
- Very low current leakage crossfader for channels 4 and 5
- Crossfader assignment switch
- Power supply : 230 V ~ 50 Hz, AC
- Power consumption: 19 W
- Dimensions : 254 x 295 x 104 mm (mounting depth: 85 mm)
- Weight : 3.4 kg





# AMPLIFIERS

# Ti154

4 voies pour plus de voix\*

\*4 ways to express yourself



Class D amplifiers

# Ti SERIES

## GENERAL SPECIFICATIONS

- Class-D amplifier
- Switched-mode power supply
- Mode selection: Stereo, Bridge or Parallel
- Independent limiter for each channel
- Extremely accurate and independent level settings for each channel
- LEDs indicators
- Convection cooled
- Balanced Jack TRS and XLR inputs
- Unbalanced RCA outputs
- Binding post-jacks or Speakon® outputs
- Short-circuit, over current and high temperature independent protections for each channel
- 2x19" rack mount spaces

## THE PERFECT MUSIC OF SILENCE

When silence is a very important factor, you can rely on the Ti series which works as silently as possible. That makes them perfect for studio, permanent installations and theatres.

These Class D amplifiers feature SMPS units and offer a perfect sound reproduction despite their ultra-compact size.

Ti500 rear panel



XLR, balanced Jack and unbalanced RCA inputs  
 Binding post-jacks and SpeakOn outputs.



- + Light and compact
- + Designed for studio and ambiance installation
- + Up to 8 speakers in stereo mode

## Ti154

4 x 150 W Amplifier  
 ref 10412

## Ti300

2 x 150 W Amplifier  
 ref 9672

## Ti500

2 x 250 W Amplifier  
 ref 9673

With every connection you need they're perfectly adapted for any sound system, studio, and even HiFi applications. They also feature thermal and electronic protections, so you can operate them safely and with great serenity.

## TECHNICAL SPECIFICATIONS

|                                | Ti154          | Ti300   | Ti500         |
|--------------------------------|----------------|---|---------------|
| Ref                            | 10412          | 9672  | 9673          |
| 4 Ω RMS stereo power (minimum) | 4 x 150 W RMS  | 2 x 150 W RMS   | 2 x 250 W RMS |
| 8 Ω RMS stereo power           | 4 x 80 W RMS   | 2 x 80 W RMS  | 2 x 130 W RMS |
| 8 Ω bridged power (minimum)    | 2 x 300 W RMS  | 1 x 300 W RMS   | 1 x 500 W RMS |
| Signal-to-noise ratio          |                | Less than 90 dB   |               |
| Input sensitivity              |                | 4 dBu +/-2 dB   |               |
| THD at 1kHz 1/2 rated power    |                | Less than 0.1%  |               |
| Slew rate                      |                | - 65 dB at 1 kHz  |               |
| Frequency response (4 Ω/1 W)   |                | +0.5 dB ; 20 Hz-20 kHz                                      |               |
| Input impedance                |                | unbalanced 15 kΩ / Balance 30 kΩ                            |               |
| Clip                           |                | 0 dB  |               |
| Cooling                        |                | Convection cooled   |               |
| Input connectors               | Combo XLR/Jack | XLR, Balanced Jack TRS + Unbalanced RCA                     |               |
| Output connectors              |                | Binding post-jacks + 4-pole Speakon®                        |               |
| Front control panel            |                | AC power switch, Channel 1 and 2 volume                     |               |
| Rear control panel             |                | Mode button   |               |
| Indicators                     |                | Protect (red) / Clip (yellow) / Signal (green)              |               |
| Protections                    |                | Short-circuits, over current and high temperature protected |               |
| Power supply                   |                | 100/230 VAC - 50/60 Hz                                      |               |
| Dimensions                     |                | 482 mm x 44 mm x 330 mm                                     |               |
| Net weight                     | 4,5 kg         | 4,3 kg  | 4,7 kg        |



High-power amplifiers

# WI SERIES

- + High-performance amplifiers
- + Perfect sound quality and powerful output
- + Optimised cooling system

## CLASSIC AMPLIFIER SERIES OPERATING UP TO 2 OHMS STEREO OR 4 OHMS BRIDGED.

The Wi amplifiers series is the result of many years of experience. The Audiophony know-how allows us to provide you with a very complete range dedicated to power and high sound quality.

Our amplifiers feature a close-to-perfect sound output, a great variety of electrical connectors, a low-pass filter and a limiter. They also benefit from the latest circuit boards and an oversized cooling system to ensure an optimal reliability and stability.



### TECHNICAL SPECIFICATIONS

|  | WI640  | WI900        | WI1200       | WI1500       | WI1800       |
|--|--|--------------|--------------|--------------|--------------|
| Ref                                      | 9561   | 9562         | 9563         | 9564         | 9565         |
| 8 Ω RMS stereo power                     | 2 x 210 W  | 2 x 300 W    | 2 x 400 W    | 2 x 500 W    | 2 x 600 W    |
| 4 Ω RMS stereo power                     | 2 x 320 W  | 2 x 450 W    | 2 x 600 W    | 2 x 750 W    | 2 x 900 W    |
| 2 Ω RMS stereo power                     | 2 x 420 W  | 2 x 700 W    | 2 x 900 W    | 2 x 1200 W   | 2 x 1400 W   |
| 8 Ω bridged power                        | 1 x 650 W  | 1 x 900 W    | 1 x 1200 W   | 1 x 1400 W   | 1 x 1800 W   |
| 4 Ω bridged power                        | 1 x 845 W  | 1 x 1400 W   | 1 x 1800 W   | 1 x 2400 W   | 1 x 2800 W   |
| Signal-to-noise ratio                    | 100 dB   | 102 dB       | 102 dB       | 104 dB       | 104 dB       |
| Distorsion (SMPTE-IM)                    | 0,05%  | 0,01%        | 0,01%        | 0,04%        | 0,04%        |
| Input sensitivity @8 ohms                | 4 dBu  | 4 dBu        | 4 dBu        | 4 dBu        | 4 dBu        |
| Voltage gain                             | 30 dB  | 32 dB        | 33 dB        | 34 dB        | 35 dB        |
| Output circuitry                         | AB   | AB           | AB           | H            | H            |
| Power consumption                        | 230 V - 50 Hz, AC  |              |              |              |              |
| Current consumption at 1/8 power @ 4 Ω   | 2,2 A  | 3,1 A        | 3,5 A        | 3,5 A        | 4,1 A        |
| Current consumption at 1/3 power @ 4 Ω   | 3,6 A  | 4,8 A        | 6 A          | 7,1 A        | 8,3 A        |
| Current consumption at rated power @ 4 Ω | 5,5 A  | 7,7 A        | 9,5 A        | 13 A         | 16 A         |
| Distortion 20 Hz-20k Hz half power       | 0,01%  | 0,01%        | 0,01%        | 0,03%        | 0,03%        |
| THD at 1kHz rated power                  | 0,1%   |              |              |              |              |
| Bandwidth                                | 20 Hz-20 kHz   | 20 Hz-20 kHz | 20 Hz-20 kHz | 20 Hz-20 kHz | 20 Hz-20 kHz |
| Damping factor (400 Hz)                  | >250   | >250         | >250         | >350         | >350         |
| Balanced/unbalanced input impedance      | 15 kΩ/ 30 kΩ   | 15 kΩ/ 30 kΩ | 15 kΩ/ 30 kΩ | 15 kΩ/30 kΩ  | 15 kΩ/30 kΩ  |
| Clip level                               | 22 dBu (10 Vrms)   |              |              |              |              |
| Cooling                                  | Continuously variable speed, Front to rear   |              |              |              |              |
| Input connectors                         | Active balanced combo (XLR and 1/4" TRS common use)  |              |              |              |              |
| Output connectors                        | Binding post-jacks + 4-pole Speakon®   |              |              |              |              |
| Front control panel                      | AC power switch, Channel 1 and 2 volume  |              |              |              |              |
| Rear control panel                       | HPF switch, Limiter switch, Mode selector switch   |              |              |              |              |
| Indicators                               | Active(blue), Protection(red), Clip(red), Signal (green & yellow)  |              |              |              |              |
| Protections                              | Short circuit, Thermal, Current limit, DC offset, Current inrush, RF protection, Turn on / Turn off muting |              |              |              |              |
| Dimensions (L x W x H)                   | 19"(482mm) x 3.5"(88mm) x 16.5"(420 mm)  |              |              |              |              |
| Weight                                   | 13.6 kg  | 16.2 kg      | 19.2 kg      | 19.5 kg      | 21.2 kg      |



# WA-4X3

4-channel amplifier

**Multi-channeling is what it does best !**

ref 9066

+ 1200 W available  
 + 4 separate channels in an ultra-compact format  
 + Very versatile: 2x2 or 2+1 or 4x1



Not even size is reason enough to limit the number of channels. The WA-4x3 is a 4-channel amplifier you can use with versatility: 4-zone, triphonic or quadriphonic sound system.

In fact, it does what every other amplifier does, but twice better.



Rear panel.

## TECHNICAL SPECIFICATIONS

- Power output :
  - 8 Ω 4 x 200 W RMS
  - 4 Ω 4 x 300 W RMS
  - 8 Ω 2 x 600 bridged stereo W RMS
  - 8 Ω 2 x 200 bridged stereo W RMS + 1 x 8 Ω 600 W RMS
- Sensitivity at 8 Ω rated power: 0.775 mV
- Frequency response (1 W) 20 Hz - 25 kHz (+0 dB, -0.5 dB)
- Phase response (1 W) 20 Hz - 20 kHz (+10°, -20°)
- Signal to noise ratio below rated power A-weighted : >100 dB
- THD: (20 Hz - 20 kHz) 0.1%
- Damping factor at 8 Ω: 20 Hz at 400 Hz >200
- Input impedance (nominally balanced): 20 kΩ
- Input impedance (nominally unbalanced): 10 kΩ
- Max load impedance : 4-channel / 4-8 Ω
- Bridged stereo : 8 Ω
- AC line voltage : 220 - 240 V; 50 - 60 Hz
- AC line current : 8 A (both amplifiers draw no more than 90 watts at idle)
- Flow-through ventilation from front to back
- Cooling: Proportional speed fan
- Dimensions : 483 x 375 x 89 mm
- Net weight: 16 kg

### A TRIPHONIC DIFFUSION:

Broadband speakers and subwoofer are powered by the same amplifier. The front panel allows you to control and optimise the sound diffusion.

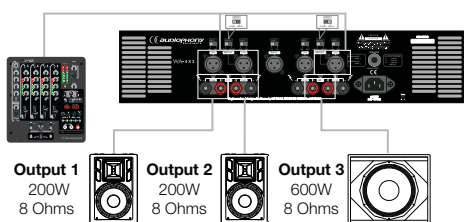

### 4 INDEPENDENT ZONES:

You can choose a unique source (bus) or 1 independent source per output.

The volume of each zone can be controlled via the front panel.

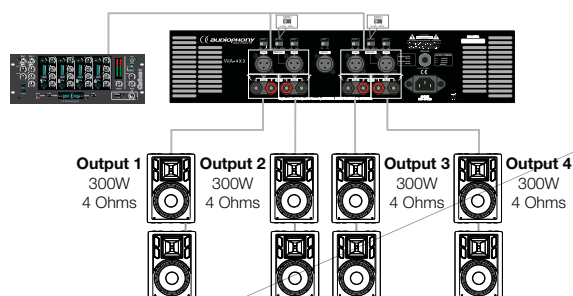

SMPS Audio amplifiers

# SMI SERIES

## THIS SERIES FEATURES POWERFUL AND LIGHT AMPLIFIERS.

Performance, reliability and sound quality. We put our know-how and experience into the SMI series and created high-definition and very resistant amplifiers.

- + Tremendous output quality
- + Important weight loss
- + All the input/output connectors you need



REAR

262

### TECHNICAL SPECIFICATIONS

|                        | <b>SMI600 - AMPLIFIER<br/>2 X 300 W RMS</b>                                       | <b>SMI1000 - AMPLIFIER<br/>2 X 500 W RMS</b> | <b>SMI1500 - AMPLIFIER<br/>2 X 750 W RMS</b> |
|------------------------|---|--|--|
| Ref                    | 9827  | 9828   | 9829   |
| 4 Ω RMS stereo power   | 2 x 300 W   | 2 x 500 W                                    | 2 x 750 W                                    |
| 8 Ω RMS stereo power   | 2 x 200 W   | 2 x 310 W                                    | 2 x 450 W                                    |
| 2 Ω RMS stereo power   | 2 x 450 W   | 2 x 600 W                                    | 2 x 1000 W                                   |
| 8 Ω bridged power      | 1 x 600 W   | 1 x 1000 W                                   | 1 x 1500 W                                   |
| 4 Ω bridged power      | 1 x 900 W   | 1 x 1200 W                                   | 1 x 2000 W                                   |
| Inputs                 | XLR + Jack TRS balanced and RCA unbalanced sockets                                |  |  |
| Outputs                | Binding post-jacks + 4-pole Speakon®  |  |  |
| Protections            | Short circuit, Thermal, Current limiter, DC offset, Current inrush, RF protection |  |  |
| Dimensions (L x W x H) | 19" x 2 U 483 x 89 x 335 mm   | 483 x 89 x 395 mm                            | 483 x 89 x 395 mm                            |
| Weight                 | 6 kg  | 6.9 kg                                       | 9.2 kg                                       |

Audio power amplifier

# AS SERIES

## HIGH-EFFICIENCY AMPLIFIERS FOR DEMANDING INSTALLATIONS

The AS series is our way to express our desire to create reliable, consistent and powerful amplifiers. They feature all the connectors you need, produce an unmatched sound quality, even at full volume, and at unbeatable value for money.

- + 3 products available
- + Huge toroidal transformer ensuring a great reliability
- + Speakon outputs



REAR

### TECHNICAL SPECIFICATIONS

|                          | AS-220 - AMPLIFIER<br>2 X 120 W RMS | AS-420 - AMPLIFIER<br>2 X 200 W RMS | AS-620 - AMPLIFIER<br>2 X 300 W RMS |
|--------------------------|-------------------------------------|-------------------------------------|-------------------------------------|
| Ref                      | 7577                                | 7578                                | 7593                                |
| 4 Ω RMS stereo power     | 2 x 120 W                           | 2 x 200 W                           | 2 x 300 W                           |
| 8 Ω RMS stereo power     | 2 x 75 W                            | 2 x 100 W                           | 2 x 220 W                           |
| Bandwith                 | 20 Hz-20 kHz                        | 20 Hz-20 kHz                        | 20 Hz-20 kHz                        |
| Distorsion at 1 kHz/50 W | <0,5%                               | <0,5%                               | <0,5%                               |
| S/N ratio                | >95 dB                              | >95 dB                              | >95 dB                              |
| Protections              | SC/DC/Vcc                           | SC/DC/Vcc                           | SC/DC/Vcc                           |
| Ventilation              | 1 fan                               | 1 fan                               | 1 fan                               |
| LED indicator            | Power/Clip                          | Power/Clip                          | Power/Clip                          |
| Inputs                   | 2 Jack 6,35                         | 2 Jack 6,35                         | 2 Jack 6,35                         |
| Outputs                  | 2 Speakon                           | 2 Speakon                           | 2 Speakon                           |
| Dimensions (L x W x H)   | 19" x 2 U x 210 mm                  | 19" x 2 U x 210 mm                  | 19" x 2 U x 370 mm                  |
| Weight                   | 8 kg                                | 10 kg                               | 14 kg                               |

0 +10 +20 dBu

OUTPUT GAIN

+5 +15 +20 dBu

PEAK

BYPASS

STEREO COUPLE

LIMITER

2.5K 4K 6.3K 10K 16K

+12

0

-12



# SP26

 Windows  
 macOS

Loudspeaker processor  
**2-in 6-out processing**  
 ref 10712

**NEW**



- + Windows user interface software for unit configuration
- + Real-time monitoring
- + Sounding performance of any small or mid sized application
- + Perfect for CUB serie

## TECHNICAL SPECIFICATIONS

- Inputs: 2 balanced inputs
- Outputs: 6 balanced outputs
- Input impedance: > 10k ohms.
- Output gain: From +12dB to -50dB, 0.25dB increment
- Input gain: From +12dB to -50dB, 0.25dB increment
- Frequency Response (-0.3dB) : 20Hz – 20kHz
- THD+N: < 0.05%
- Max delay: 5ms
- Dynamic range: > 98dB
- Minimum load impedance : 600 Ohms
- Maximum output level : +9dBu (600 Ohms load)
- Sampling rate: 96kHz, 24 bit depth
- Crossover / EQ operational frequency band: 20Hz – 20kHz
- Crossover filtering : Bessel, Butterworth (6, 12, 24 and 48dB/Octave), Linkwitz-Riley (12 and 24dB/Octave)
- 10-band EQ type: Bell, Notch, All Pass, Band Pass, Low/High Pass, Low/High Shelf
- Equalizer gain: Adjustable from -12dB to +12dB
- Equalizer Q: Adjustable from 0.2 to 25
- Phase inversion: Yes
- Limiter release time: Adjustable from 10 to 100
- Limiter threshold: Adjustable from -48dB to 9dB
- LCD Display: 2x16 character
- Password protection: Yes
- Device presets: 50
- Language options: English, Germany, Spanish, French, Dutch
- Signal inputs: XLR Female socket
- Signal outputs: XLR Male socket
- Computer link: USB
- Mains power: 3 cores ICE socket
- Product Dimensions (mm): 483 x 127 x 45 (1U)
- Weight: 3kg

# Q215

Stereo equalizer  
**A real pro EQ in a compact format**  
 ref 9670



- + Balanced and unbalanced inputs/ outputs
- + Clear signal
- + Independent recording outputs

## TECHNICAL SPECIFICATIONS

- 2/3 Octave from 31,5 Hz - 16 kHz stereo equalizer
- Adjustable output level / +12/-12 dB
- 20 mm faders
- Frequency response : 20 Hz - 20 kHz
- Frequency settings : +/-12 dB (+/-0,5 dB )
- Low-pass filter for each channel (60 Hz -3 dB)
- Balanced inputs : XLR, Jack 6,35 TRS
- Unbalanced inputs : RCA
- Balanced outputs : XLR, Jack 6.35 TRS
- Unbalanced outputs : RCA
- Unbalanced recording output (REC OUT) RCA (output level: -6 dB )
- Signal level indicator : -10 dB, 0 dB, +10 dB, +17 dB
- By-pass and low-pass indicators
- Power supply: 110/230 V - 50/60 Hz
- Power consumption : 15 W
- Dimensions : 483 x 44 x 190 mm
- Weight : 2.4 kg

# X312

Active filter  
**A simple and efficient filter to optimise your sound system**  
 ref 9669



- + Pre-set independent subwoofers output
- + 2-way stereo or 3-way mono
- + Low frequencies sum mono mode

## TECHNICAL SPECIFICATIONS

- XLR balanced and unbalanced output +4 dB
- Stereo (2-way + subwoofer) or mono (3-way + subwoofer) modes
- Low frequencies sum mono mode
- Low/medium/high frequencies phase inversion
- Stereo mode :
  - Adjustable input level
- Adjust independently the HF and LF cut-off frequencies (45 at 960 Hz)
- Adjust independently the HF and LF output levels
- Optionally, you can use the SUB output with level and cut-off frequency settings (20-200 Hz)
- Mono mode :
  - Adjustable input level
  - Adjust independently the HF and LF cut-off frequencies (45 at 960 Hz and at 9600 Hz)
- Adjustable LF/medium/HF frequencies output level
- Optionally, you can use the SUB output with level and cut-off frequency settings (20-200 Hz)
- Power supply : 230 V - 50/60 Hz
- Power consumption : 15 W
- Dimensions : 483 x 175 x 44 mm
- Weight : 2 kg

**SPEAKERS**

# SYSTÈME HELIUM

Le son propulsé de qualité hi-fi\*

\*Crazy power, hi-fi quality



Pick and mix system with active subwoofer and passive satellites.

The whole set can be used as mini line array or 2.1 sound system on its stand, thanks to its optional accessories..



The Helium system has been designed to answer the needs of installers who want to enjoy the line array technology while preserving space and easy installation.

High-quality mid and high frequencies combined with the directional characteristics of the system will let you enjoy crystal clear, precise music.

- + Two active subwoofers available
- + Very compact satellites with rich sound output
- + Subtle, adaptable, perfect for all installations



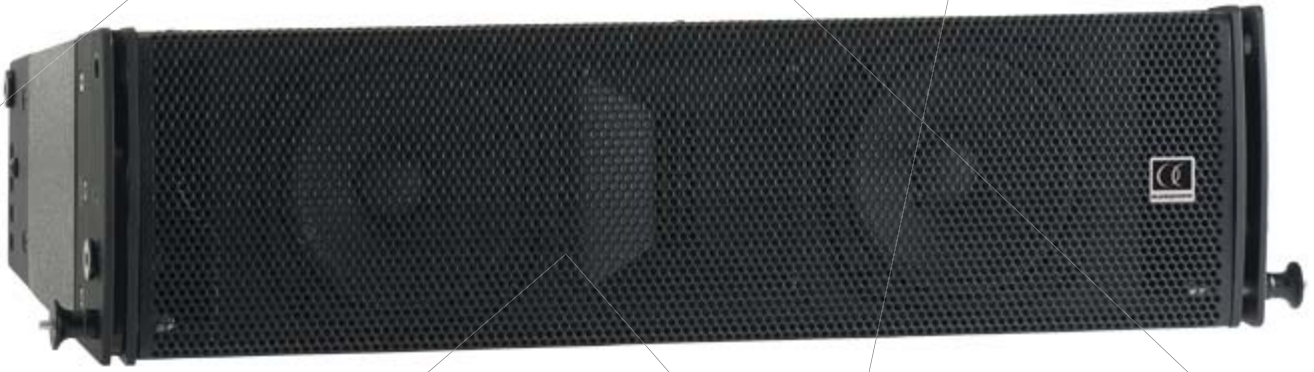

# HL-4

Compact passive line array satellites  
Ref 10518



The ribbon tweeter originates from the HiFi world and brings a lot to HL-4: transparency, ventilation, rendering and dynamism to high frequencies.

Fixation accessories allow you to mount satellites on stands, suspend them independently in permanent installations or even stack them in the air with their subwoofer for biggest installations.



- Power : 100W RMS - 200W max
- Frequency response : 150 Hz - 25 KHz
- Max SPL (à 1 m) : 121 dB
- Nominal impedance 16 Ohms
- Boomer : 2x4 pouces
- Dispersion : Waveguide pavilion (HxV) 120° x 30° to 90° depending the angle
- Connecteurs : IN/OUT speakon
- Dimensions : 485x135x260 mm
- Net weight: 5,2 kg

# HL-BUMPER

Hanging system for the whole set  
Ref 10521

Allows you to suspend 8 satellites and 2 subwoofer (max.)  
Max. supported weight: 110 kilos

HLWB4 - 4 inches 8 Ohms Boomer for HL-4 - Ref 10587

HLTR - 8 Ohms Ribbon tweeter for HL-4 - Ref 10590

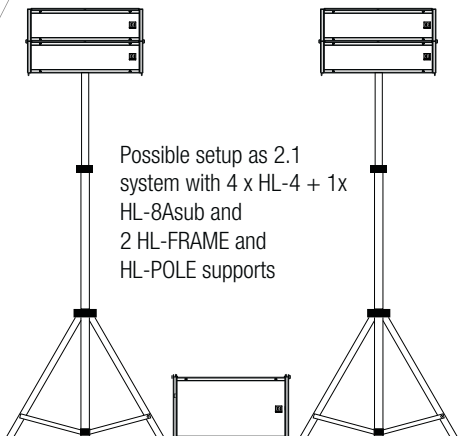

Possible setup as 2.1 system with 4 x HL-4 + 1x HL-8Asub and 2 HL-FRAME and HL-POLE supports

# HL-POLE

Baseplate for HL-FRAME  
Ref 10523

Allows you to mount HL-FRAME onto a stand and use it as 2.1 system.

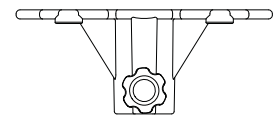

# HL-FRAME

Hanging system for HL-4 satellites  
Ref 10522

Allows you to hang 4 satellites to the ceiling of your installation

Max. supported weight: 25 kilos

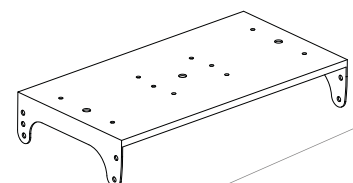



# HL-8Asub

2x8" subwoofer for active, compact line array system  
Ref 10519

Active subwoofers complete your whole installation depending on room requirements and allow simplified use, without any additional device.



## HL-8Asub

- Power : 300W RMS - 600W max
- Frequency response : 80 - 200Hz
- Max SPL (@1m) : 110 dB
- Nominal impedance : 4 Ohms
- Boomer : 2 x 8 pouces
- Dimensions : 485 x 540 x 260 mm
- Net weight : 19,2 kg

HLWB8 - 8 inches and 8 Ohms boomer for HL-08ASUB  
Ref 10588

## AMPLIFICATION

- Low frequencies 2 x 200W RMS / Classe D - 8 Ohms
  - Mid.High frequencies 2 x 200W RMS / classe D - 8 Ohms
- For a total of 800W max
- Inputs :
    - 2 x Line Level Combo XLR/JACK
  - Sorties
    - 2 x Line Level Combo XLR/JACK
    - 2 x amplified speakon for satellites
  - Settings :
    - Volume : Main volume settings
    - Bass : Subwoofer settings
    - STEREO / PARALLEL selector to switch from 2.1 to Line Array mode



# HL-10Asub

2x10" subwoofer for active, compact line array system  
Ref 10520

Active subwoofers complete your whole installation depending on room requirements and allow simplified use, without any additional device.

## HL-10Asub

- Power : 400W RMS - 800W max
- Frequency response : 50 - 200Hz
- Max SPL (@1m) : 114 dB
- Nominal impedance : 4 Ohms
- Boomer : 2 x 10 pouces
- Dimensions : 485 x 540 x 310 mm
- Net weight : 29,2 kg

HLWB10 - 10 inches and 8 Ohms boomer for HL-010ASUB  
Ref 10589

## AMPLIFICATION

- Low frequencies 2 x 320W RMS / Classe D - 8 Ohms
- Mid.High frequencies 2 x 200W RMS / classe D - 8 Ohms
- For a total of 1040W max
- Inputs :
  - 2 x Line Level Combo XLR/JACK
- Sorties
  - 2 x Line Level Combo XLR/JACK
  - 2 x amplified speakon for satellites
- Settings :
  - Volume : Main volume settings
  - Bass : Subwoofer settings
  - STEREO / PARALLEL selector to switch from 2.1 to Line Array mode



# NOUVEAU SYSTÈME CUBsat

Faites voyager le son jusqu'au spectateur\*

\*Make the sound travel to the audience





# CUBsat4 SERIES

Creating a discreet sound system with both an attractive design and high-quality output regardless of its location or usage is one of the hardest challenges to face.

## “MODULARITY” IS THE CORNERSTONE OF THIS SYSTEM

This concept is appealing, for both permanent and temporary installations. Our CUBsat4 speaker can be added to any regular multi-source installation, of course, but it can also be part of Line Array columns thanks to its smart coupling and angulation system, with up to 8 speakers per column.

Under this scenario, no need for a multitude of amplifiers or power sources since each speaker features its own built-in cabling system: only one amplifier is required to power up both your columns of 8 x CUBsat4.

## WELL THOUGHT-OUT FIXATION SYSTEM

A wide variety of accessories is available, should it be for one speaker, a whole column, for a wall, a ceiling or a speaker stand, and any other case.

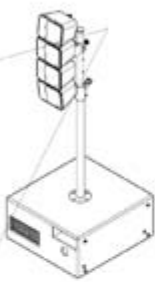
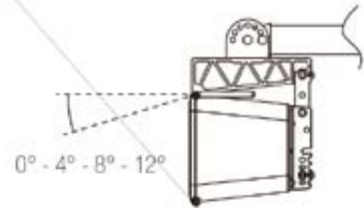
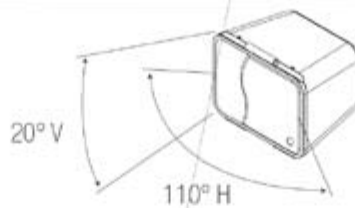

Our CUBsat4 speakers all feature an adjustable directivity (110° Horizontal x 20° vertical). This feature allows to modify the speaker dispersion in order to meet the acoustic requirements of most places.

By coupling several speakers together, and thanks to this adjustable directivity, you will create a Line Array sound system with adjustable angulation from 0° to 12°.

Two subwoofers designed to perfectly fit our CUBsat4 are available.

First of all, the CUBsub208, perfect for permanent installations thanks to its discreet design and its supplied wall-mount system.

Then comes the CUBsub112, which is an excellent addition to any temporary installation.



# CUBsat4

Passive mini line array satellite.  
 ref 10663

- Power output: 30W RMS - 90W max
- Frequency response: 100Hz - 20KHz
- Filter : Passive 2-way filter at 3kHz
- Max SPL. (@1m): 91 dB
- Nominal impedance: 8 per module with built-in impedance transformer.
- Boomer: 4" (neodymium)
- Tweeter: 3 x 0,5" soft dome
- Dispersion: Wave guide pavilion (HxV) 110° x 20° per module
- Cluster orientation: 0°/4°/8°/12°
- Connectors: via 3x Jack 6,35 Input and serial and parallel link
- Material: Die-cast aluminium housing and fixation bracket, steel pin and hinge. Black finish
- Dimensions: 170 x 140 x 150 mm
- Net weight: 1,450 kg

- + Two passive subwoofer choices
- + Very compact satellites with clear output
- + Very discreet and versatile, perfect for installations

**NEW**

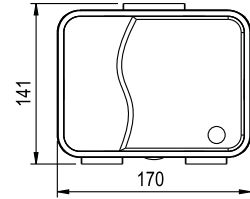
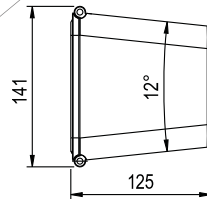

Optimize your installation with the SP26 sound processor ideally designed for the CUBsat system (p.265)

274

# CUB-bracket

Suspension bracket for CUBsat4.

**Allows you to hang up to 8 CUBsat4**

ref 10666

Fixation system and built-in impedance converter  
 To connect up to 8 satellites together, at 40hms.

## ACCESSORIES

- CUB-Pole 1 - Foot support for CUBsat4 - ref 10731
- CUB-Truss1 - Fixation support for CUBsat4 - ref 10732
- CUB-Wall1 - Wall support for CUBsat4 - ref 10730

**NEW**



# CUBsub208

Passive subwoofer with 2 x 8" speakers.

**Discreet and compact format perfect for installations**

ref 10665

**NEW**



- Power output: 300W RMS - 600W max
  - Frequency response: 50Hz -800Hz
  - Filter: does not feature any passive filter
  - Max. SPL (@1m): 124 dB
  - Nominal impedance: 4 Ohms
  - Boomer: 2 x 8" with 50mm coil
  - Connectors: via 2x speakon and In/Out via terminal
  - Material: Plywood housing and metal grille.
- Slot for coupling bar on top and rubber feet below and side inserts for wall fixation bracket.
- Black finish.
- Dimensions: 250 x 510 x 540 mm
  - Net weight: 18,5 kg



The subwoofer can be hung to a wall with 4 fixation hooks (only CUBsub208)

**NEW**



# CUBsub112

12" passive subwoofer

**Design bass reflex**

ref 10664

275

- Power output: 300W RMS - 600W max
  - Frequency response: 45Hz -2,8KHz
  - Filter: does not feature any passive filter
  - Max. SPL (@1m): 125 dB
  - Nominal impedance: 8 Ohms
  - Boomer: 12" with 64 mm coil
  - Connectors: par 2x speakon et bornier pour In/Out
  - Material: Plywood housing and metal grille.
- Slot for coupling bar on top and rubber feet below.
- Black finish.
- Dimensions: 350 x 500 x 540 mm
  - Net weight: 20 kg



# GOA

## GAMME SR

Robustesse, puissance, excellence\*...

\*SR SERIES: Protection, power, excellence...



by  **audiophony**<sup>®</sup>  
EQUIPMENTS



# Active speakers and 2-way passive speakers

## Bass reflex

### Protection

The SR speakers were designed and built for intensive live performances. They are light, robust, and very handy. The 7.5mm HPP housing guarantee an unrivaled solidity.

### Power

The incredible SR speakers sound output comes from a D and AB bi-amplification up to 400W RMS, with an outstanding 124 dB SPL.

### Excellence

No matter how hard you push it, the SR series will provide a balanced, dynamic output. These very powerful speakers have an outstanding sound quality, without any distortion even at full power.



SR 15A

We kept in mind two special criterias: efficiency and simplicity. You can access all the settings (volume control, equalizer...) via the rear panel.



Stackable

### Gamme SR : Excellence in a passive way

The SR series speakers are now available in passive versions. Of course, they retain all the qualities of their active peers: a high-quality manufacturing job, and a perfect sound rendering.

The SR series passive speakers are very resistant and easy to use, you can safely transport and use them in all circumstances.

They deliver a powerful, clear and warm 250 to 350 W sound output adapted to vocal performances and live or record music.

The COV-SR10/12/15 are the perfect protective cover to safely transport your SR series passive speakers.

2 monitor-specific angles

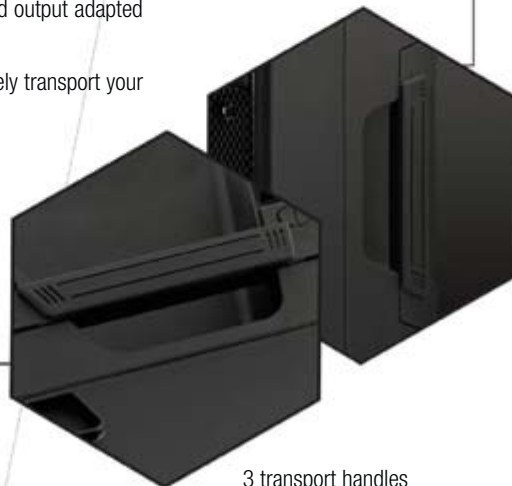

3 transport handles



# SR15A

2-way self-powered speaker – Bass reflex

**High definition and deep basses**

ref 10159

The SR15A self-powered speaker delivers 400W RMS of deep, chest-pounding basses and close-to-perfect high frequencies. Built for stage and installation, the SR15A offers the best power-to-weight ratio.

- + Class D and AB amplifier design 400 W RMS
- + Limiter and equalizer DSP
- + 2 monitor-specific angles

- Power output : 400 W RMS/800 W Max :
  - 350 W RMS Class D LF
  - 50 W RMS Class AB HF
- Switched- mode power supply (SMPS)
- Frequency response : 20 Hz-20 kHz
- HxV Dispersion : 90°x60°
- Cross-over frequency : 3.4 kHz
- SPL : 124 dB max
- Speaker : 15"x3", 4 Ohms , 350 W AES
- Driver : 1.35", 8 Ohms, 50 W RMS
- MIC/LINE input - XLR combo
- Line output - XLR
- Volume control
- Equalizer modes: Flat, Live, DJ and Vocal
- Protections : short-circuit, thermal and limiter
- 2 Monitor-specific angles
- 1 top and 2 side handles
- Installation M10 rigging points
- 36mm socket for speaker stand
- Dimensions : 410 x 450 x 710 mm
- Net weight : 21.1 kg



278

## COV-SR15

Protective cover

ref 10169

Protect your speakers from transport and time damages with our high quality covers.

- Strong reinforced construction
- Use your speaker and access its functions while it is cover-protected.
- Direct access to the transport handles.



# SR12A

2-way self-powered speaker – Bass reflex

**An ideal sound balance**

ref 10158

- + Class D and AB amplifier design  
400 W RMS
- + Limiter and equalizer DSP
- + 2 monitor-specific angles



No matter how hard you push the SR12A, it will deliver a very balanced output, and a premium high-definition sound. It can also be used as a monitor speaker and is both very powerful and easy to transport, which means it has an excellent power-to-weight ratio.

- Power output : 400 W RMS/800 W Max :
  - 350 W RMS Class D LF
  - 50 W RMS Class AB HF
- Switched- mode power supply (SMPS)
- Frequency response : 20 Hz-20 kHz
- HxV Dispersion : 90°x60°
- Cross-over frequency : 2.8 kHz
- SPL : 123 dB max
- Speaker : 12"x3", 4 Ohms , 350 W AES
- Driver : 1.35", 8 Ohms, 50 W RMS
- MIC/LINE input - XLR combo
- Sortie Line sur XLR
- Volume control
- Equalizer modes: Flat, Live, DJ and Vocal
- Protections : short-circuit, thermal and limiter
- 2 Monitor-specific angles
- 1 top and 2 side handles
- Installation M10 rigging points
- 36mm socket for speaker stand
- Dimensions : 360 x 400 x 630 mm
- Net weight : 19.2 kg



279

## COV-SR12

Protective cover

ref 10168

Protect your speakers from transport and time damages with our high quality covers.

- Strong reinforced construction
- Use your speaker and access its functions while it is cover-protected.
- Direct access to the transport handles.

# SR10A

2-way self-powered speaker – Bass reflex

**Small size, big power**

ref 10157

Despite its compact size, the SR10A offers a crystal clear, yet powerful and balanced output. The best part is it also works perfectly as monitor speaker.

- Power output : 300 W RMS/60 W Max :
  - 250 W RMS Class D LF
  - 50 W RMS Class AB HF
- Switched- mode power supply (SMPS)
- Frequency response : 20 Hz-20 kHz
- HxV Dispersion : 90°x60°
- Cross-over frequency : 2,8 kHz
- SPL : 121 dB max
- Speaker : 10"x2".5 Ohms , 250 W AES
- Moteur 1". 8 Ohms, 50W
- MIC/LINE input - XLR combo
- Line output - XLR
- Volume control
- Equalizer modes: Flat, Live, DJ and Vocal
- Protections : short-circuit, thermal and limiter
- 2 Monitor-specific angles
- 1 top and 2 side handles
- Installation M10 rigging points
- 36mm socket for speaker stand
- Dimensions : 310 x 335 x 530 mm
- Net weight : 13.4 kg

- + Class D and AB amplifier design – 300 W RMS
- + Limiter and equalizer DSP
- + 2 monitor-specific angles



280

## COV-SR10

Protective cover

ref 10167

Protect your speakers from transport and time damages with our high quality covers.

- Strong reinforced construction
- Use your speaker and access its functions while it is cover-protected.
- Direct access to the transport handles.





# SRSUB18A

18 inches 600W active Subwoofer with adjustable filter.

**A newcomer in the "SR" family**

ref 10713

**NEW**

Available  
june 2017



- Power output: 600W RMS / 1200W max.
- Frequency response: 35 Hz - 150 Hz
- Filter cut-off frequency: de 60 à 150 Hz
- Settings:
  - Phase 0-180°
  - Volume
  - Cut-off frequency
- Max. SPL: 127 dB
- Woofer:
  - 18 inches
  - 4 inches coil
  - 8 Ohms - 800W
- Inputs: 2 Combo Jack/XLR inputs
- Outputs: 2 Balanced XLR outputs

- Protections: thermal and short-circuit protections
- Materials:
  - Band-pass housing with double push-pull charge
  - 2 side handles
  - 4 wheels with rear brakes
  - 36 mm baseplate on top
  - 4 rubber feet below
  - Ultra-resistant paint
  - Class D amplifier with switched-mode power supply
- Dimensions: 770 x 680 x 560 mm
- Net weight: 39 Kg

Standard configurations:

- 2 x SR12A and 1 x SRSUB18A
- 2 x SR15A and 2 x SRSUB18A

# SRSUB15A

15 " 500W self-powered subwoofer with adjustable filter

**A weighty addition to the SR series**

ref 10349



- + Deep basses
- + 500W RMS Class D amplifier
- + Filter and volume control

It delivers a 500W RMS sound output with precise, deep and chest-pounding basses.

With its Stereo and Sum-Mono modes, it adapts to your configuration. It is compact, light and perfectly protected by its steel mesh grille. A close to perfect subwoofer for nomad and permanent installations.

## COV-SRSUB15A

Protect your subwoofer with the COV-SRSUB15A protective transport cover.

ref 10351

- Power output : 500W RMS / 1000W max.
- Frequency response : 40 Hz - 150 Hz
- Cutoff frequency : de 60 à 150 Hz
- Settings :
  - Phase 0-180°
  - Volume
  - Cross-over frequency
- SPL : 95 dB
- LF driver :
  - 15 "
  - 4 " coil
  - 8 Ohms - 800W
- Input :
  - 2 Inputs Combo Jack/XLR
- Output :
  - 2 Balanced XLR outputs
- Protection : SC,Th
- Housing
  - Bandpass dual chambered box
  - 2 side handles
  - 4 self-braking wheels
  - 36mm mounting plate (top)
  - 4 rubber feet (below)
  - Highly resistant sand texture paint
  - Class D amplifier
  - SMPS
- Dimensions : 702 x 560 x 472 mm
- Net weight : 34 Kg

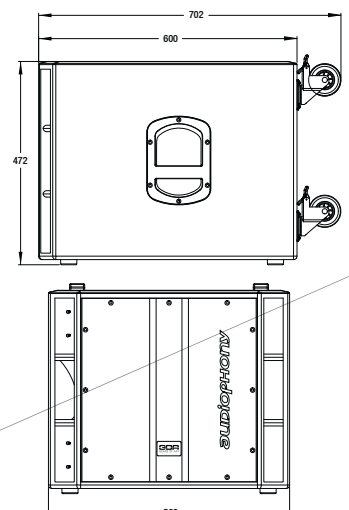

# SR15P

SR series passive speakers

ref 10270

- Power output : 350W RMS / 700W max.
- Frequency response : 45 Hz - 20 KHz
- Dispersion H x V : 90° x 60°
- Filter cutoff frequency : 2.1 KHz
- SPL : 96 dB max.
- LF driver :
  - 15 "
  - 3 " coil
  - 8 Ohms - 300W
- HF driver
  - 1.35 "
  - 8 Ohms
  - 50 W
- Input: 1 Speakon® input
- Output: 1 Speakon® output
- Protection : PTC
- Housing and fixation system:
  - 2 monitor-specific angles
  - 1 top handle
  - 2 side handles
  - 2 M10 rigging points (below)
  - 1 M10 rigging point (rear)
  - 2 M10 rigging points (on top)
  - 36mm socket for speaker stand with clamping knob
- Dimensions : 410 x 450 x 710 mm
- Net weight: 19.2 Kg



- + Easy to use
- + Robustness
- + Clear and warm sound
- + 2 monitor-specific angles



282

## COV-SR15

Protective cover

ref 10169

Protect your speakers from transport and time damages with our high quality covers.

- Strong reinforced construction
- Use your speaker and access its functions while it is cover-protected.
- Direct access to the transport handles.



# SR12P

SR series passive speakers  
ref 10269

- + Easy to use
- + Robustness
- + Clear and warm sound
- + 2 monitor-specific angles



- Power output: 350W RMS / 700W max.
- Frequency response: 55 Hz - 20 KHz
- Dispersion H x V : 90° x 60°
- Filter cutoff frequency : 2.1 KHz
- SPL : 96 dB max.
- LF driver:
  - 12 "
  - 3 " coil
  - 8 Ohms - 300W
- HF driver:
  - 1.35 "
  - 8 Ohms
  - 50 W
- Input: 1 Speakon® input
- Output: 1 Speakon® output
- Output: 1 Speakon® output
- Housing and fixation system:
  - 2 monitor-specific angles
  - 1 top handle
  - 2 side handles
  - 2 M10 rigging points (below)
  - 1 M10 rigging point (rear)
  - 2 M10 rigging points (on top)
  - 36mm socket for speaker stand with clamping knob
- Dimensions : 360 x 400 x 630 mm
- Net weight: 17.8 Kg



283

## COV-SR12

Protective cover  
ref 10168

Protect your speakers from transport and time damages with our high quality covers.

- Strong reinforced construction
- Use your speaker and access its functions while it is cover-protected.
- Direct access to the transport handles.

# SR10P

SR series passive speakers

ref 10268

- Power output: 250W RMS / 500W max.
- Frequency response: 65 Hz - 20 KHz
- Dispersion H x V: 90° x 60°
- Filter cutoff frequency: 2.1 KHz
- SPL: 94 dB max.
- LF driver:
  - 10 "
  - 2,5 " coil
  - 8 Ohms - 200W
- HF driver:
  - 1 "
  - 8 Ohms
  - 50 W
- Input: 1 Speakon® input
- Output: 1 Speakon® output
- Protection: PTC
- Housing and fixation system:
  - 2 monitor-specific angles
  - 1 top handle
  - 2 side handles
  - 2 M10 rigging points (below)
  - 1 M10 rigging point (rear)
  - 2 M10 rigging points (on top)
  - 36mm socket for speaker stand with clamping knob
- Dimensions: 310 x 335 x 530 mm
- Net weight: 11.8 Kg

- + Easy to use
- + Robustness
- + Clear and warm sound
- + 2 monitor-specific angles



284

## COV-SR10

Protective cover

ref 10167

Protect your speakers from transport and time damages with our high quality covers.

- Strong reinforced construction
- Use your speaker and access its functions while it is cover-protected.
- Direct access to the transport handles.







|                                   | <b>SR15A</b>                              | <b>SR12A</b>                              | <b>SR10A</b>                              | <b>SR15P</b>                    | <b>SR12P</b>                    | <b>SR10P</b>                    |
|-----------------------------------|---|---|---|---------------------------------|---------------------------------|---------------------------------|
| <b>Ref</b>                        | 10159                                     | 10158                                     | 10157                                     | 10270                           | 10269                           | 10268                           |
| <b>RMS output</b>                 | 400 W                                     | 400 W                                     | 300 W                                     | 350 W                           | 350 W                           | 250 W                           |
| <b>Max output</b>                 | 800 W                                     | 800 W                                     | 600 W                                     | 700 W                           | 700 W                           | 500 W                           |
| <b>RMS LF output</b>              | 350 W                                     | 350 W                                     | 250 W                                     | 300 W                           | 300 W                           | 200 W                           |
| <b>RMS HF output</b>              | 50 W                                      | 50 W                                      | 50 W                                      | 50 W                            | 50 W                            | 50 W                            |
| <b>Amp class</b>                  | D + AB                                    | D + AB                                    | D + AB                                    | -                               | -                               | -                               |
| <b>Power supply</b>               | SMPS                                      | SMPS                                      | SMPS                                      | -                               | -                               | -                               |
| <b>Protection</b>                 | Short-circuit, thermal and limiter        | Short-circuit, thermal and limiter        | Short-circuit, thermal and limiter        | -                               | -                               | -                               |
| <b>Frequency response</b>         | 40 Hz-20 kHz                              | 45 Hz-20 kHz                              | 55 Hz-20 kHz                              | 45 Hz - 20 kHz                  | 55 Hz - 20 kHz                  | 65 Hz - 20 kHz                  |
| <b>H x V dispersion</b>           | 90° x 60°                                 | 90° x 60°                                 | 90° x 60°                                 | 90° x 60°                       | 90° x 60°                       | 90° x 60°                       |
| <b>Cross-over frequency</b>       | 3.4 kHz                                   | 2.8 kHz                                   | 2.8 kHz                                   | 2.1 kHz                         | 2.1 kHz                         | 2.1 kHz                         |
| <b>Sound pressure level (SPL)</b> | 124 dB                                    | 123 dB max                                | 121 dB max                                | 96 dB max                       | 96 dB max                       | 94 dB max                       |
| <b>Woofer</b>                     | 15"x3"                                    | 12"x3"                                    | 10"x2.5"                                  | 15"x3"                          | 12"x3"                          | 10"x2.5"                        |
|                                   | 4 Ohms                                    | 4 Ohms                                    | 4 Ohms                                    | 8 Ohms                          | 8 Ohms                          | 8 Ohms                          |
| <b>HF driver</b>                  | 350 W AES                                 | 350 W AES                                 | 250 W AES                                 | 300 W AES                       | 300 W AES                       | 200 W AES                       |
|                                   | 1.35"                                     | 1.35"                                     | 1"  | 1.35"                           | 1.35"                           | 1"                              |
|                                   | 8 Ohms                                    | 8 Ohms                                    | 8 Ohms                                    | 8 Ohms                          | 8 Ohms                          | 8 Ohms                          |
| <b>Pre-amplification</b>          | 50 W RMS                                  | 50 W RMS                                  | 50 W RMS                                  | 50 W RMS                        | 50 W RMS                        | 50 W RMS                        |
|                                   | MIC/LINE input - XLR combo                | MIC/LINE input - XLR combo                | MIC/LINE input - XLR combo                | -                               | -                               | -                               |
|                                   | XLR line output                           | XLR line output                           | XLR line output                           | -                               | -                               | -                               |
|                                   | Volume control                            | Volume control                            | Volume control                            | -                               | -                               | -                               |
| <b>Housing</b>                    | Equalizer modes: Flat, Live, DJ and Vocal | Equalizer modes: Flat, Live, DJ and Vocal | Equalizer modes: Flat, Live, DJ and Vocal | -                               | -                               | -                               |
|                                   | 2 Monitor-specific angles                 | 2 Monitor-specific angles                 | 2 Monitor-specific angles                 | 2 Monitor-specific angles       | 2 Monitor-specific angles       | 2 Monitor-specific angles       |
|                                   | 1 top and 2 side handles                  | 1 top and 2 side handles                  | 1 top and 2 side handles                  | 1 top and 2 side handles        | 1 top and 2 side handles        | 1 top and 2 side handles        |
|                                   | Installation M10 rigging points           | Installation M10 rigging points           | Installation M10 rigging points           | Installation M10 rigging points | Installation M10 rigging points | Installation M10 rigging points |
|                                   | 36mm socket for speaker stand             | 36mm socket for speaker stand             | 36mm socket for speaker stand             | 36mm socket for speaker stand   | 36mm socket for speaker stand   | 36mm socket for speaker stand   |
| <b>Dimensions (H x W x P)</b>     | 410 x 450 x 710 mm                        | 360 x 400 x 630 mm                        | 310 x 335 x 530 mm                        | speaker stand                   | 360 x 400 x 630 mm              | 310 x 335 x 530 mm              |
| <b>Net weight</b>                 | 21.1 kg                                   | 19.2 kg                                   | 13.4 kg                                   | 19.2 kg                         | 17.8 kg                         | 11.8 kg                         |

# ENCEINTE MT12A-UHF

La solution mobile qui a de la voix\*

\*NEW MT12A-UHF SPEAKER : it is coming with great fanfare





# MT12A-UHF

The all-inclusive MT self-powered speaker  
ref 10286

## Powerful

Always as powerful and more innovative. It retains all the qualities and features our reputations was built on: powerful, light and adaptable speakers.

- + Supplied with 2 UHF microphones
- + Class D and AB amplifier
- + 2 inputs Line mic and Line/Aux



## Double UHF handheld built-in system :

The MT12A-UHF is supplied with two independent UHF handheld microphones perfectly integrated into the amplification module. The speaker features a preamplifier allowing you to combine the 2 UHF mic with other sources, for professional and public animations or speeches.



Compatible with the CR12 Headset

## COV-MT12

Protective cover

**Protect your MT12A-UHF speaker from time and transport damages with the COV-MT12 protective cover**

ref 9965



### Bi-amplification:

- 250W RMS Class D for LF
- 50W RMS Class AB for HF
- Total power output: 300W RMS / 600W max.

Frequency response: 55 Hz - 20 KHz

Power supply: SMPS

Dispersion H x V: 120° x 60°

Filter cutoff frequency: 2.8 KHz

SPL: 122 dB max.

LF driver:

- 12"
- 2" coil
- 4 Ohms - 250W RMS

HF driver:

- 1.35"
- 8 Ohms
- 50 W RMS

Inputs:

- 1 COMBO XLR/JACK MIC/LINE input

- 1 Mini Jack and Combo XLR/JACK LINE/AUX input

Output: 1 XLR (Master) line output

Settings:

- Settings volume for each channel
- Settings HIGH/LOW +/- 15 dB main

Micro HF:

- UHF diversity with 16 frequencies
- Handheld dynamic cardioid microphone (infrared sync)

Frequency ranges: UHF 863-865 Mhz - 10 mW

Protection: Short-circuit, thermal and limiter

Housing and fixation system:

- 2 monitor-specific angles
- 1 top handle and 2 side handles
- 2 M10 rigging points (below)
- 2 M10 rigging points (on top)
- 36mm mounting plate for a speaker stand

Dimensions: 385 x 348 x 595 mm

Net weight: 16.6 Kg

# MT10SYS

La solution scène compacte de génie\*

\*The genius compact stage sound system





# MT10SYS

2 speakers and 1 mixer set

**A brilliant, compact scene performer**

ref 10205

 **Bluetooth®\***



- + Light, compact and very handy
- + Easy to use
- + High sound quality and great performance

What a simple way to make the show. Mt10Sys is designed for small places, bars and home training sessions. Whatever the kind of musician, speaker or presenter you are, it offers a compact, powerful and versatile way to achieve your goal.

With a total of 600W, a compact mixer with 4 mic/instrument inputs, 2 line inputs, and a Bluetooth® input, MT10Sys is exactly what you need. We also added an adjustable Reverb effect to get a super-powerful, affordable and easy-to-use professional sound system.

## TECHNICAL SPECIFICATIONS

|  |  |
|--|--|
| GOA MT10P:   | Reverb assignable to each mic channel with volume and delay control  |
| Power output : 150+30 W RMS  | 15V Phantom power supply   |
| Response frequency : 60 Hz - 20 kHz                                      | LED view meter with Limiter visualisation                            |
| Max SPL (@1m) : 119 dB   | Two inputs with independent volume control (Master and Monitor)      |
| Nominal impedance : 4 Ohms   | Monitor output via Jack  |
| Boomer : 10" with a 2" coil  | Jack subwoofer output with low-pass filter                           |
| Tweeter : 1"   | Master 2x300 W pgm output via Jack                                   |
| Dispersion : 120° x 60°  | You can remove the mixer from the speakers using the fastening clips |
| Connector : 1 x jack 6.35  | You can pole mount it thanks to the 2 M5 inserts (60mm)              |
| Cable and mixer storage compartments (2x5m fournis) at the rear          | Dimension (L x W x P) : 315 x 180 x 80 (110) mm                      |
| 35mm socket for speaker stand  | Weight : 2.7 kg  |
| Built-in handle (rear)   | Additional characteristics :   |
| Dimensions : 495 x 321 x 291 mm  | Amplifier RMS power output: 2 x 150 W RMS / 2 x 300 W pgm            |
| Weight : 9.7 kg per speaker  | Class D amplifier  |
| Mixer :  | Class 2 Bluetooth® : average range of 10 m                           |
| 8-band mixer   | Power supply : 100-240V - 50/60Hz                                    |
| 4 Jack or XLR micro/line mono inputs with source selection               | Power consumption : 600W max   |
| 2 Line stereo inputs via Jack and/or RCA                                 | 2x5m Jack/Jack cable supplied  |
| 1 built-in Bluetooth® receiver   |  |
| 2-band equalizer per channel (+/- 15dB) + preset programs: Vocal or Live |  |

## COV-MT10

Protect your system using 2x COV-MT10

ref 9964



## MT10A-MIX

Passive speaker with a removable mixer/amplifier (included)

ref 10206



## MT10P

Passive speaker with storage compartments and two 5m jack/jack cables

ref 10207



Powered ABS speakers

# ACUTE ACTIVES SERIES

Be active, live what you hear

The ACUTE active speaker series features 8 inches loudspeakers.

They have an unparalleled adaptability: you can daisy-chain several speakers together via a single XLR cable. Each speaker has a built-in amplifier specifically designed for it. This means they safely work at their best. They are setup-friendly, and work independently to fit any kind of installation. Power, adaptability and ease-of-use are the key words to describe the ACUTE series.

- + Ultra-resistant polypropylene housing
- + Full input panel with Micro/Line plugs
- + 2 monitor-specific angles



## YOU ASK, THEY ADAPT.

The ACUTE Amps can be integrated to most installations thanks to their mounting sockets and their wide range of mounting accessories.



## AN OPTIMIZED AMPLIFIER MODULE

The built-in module was designed to meet professionals needs:

- Extremely powerful amplifier
- A whole lot of micro/line inputs
- Highly efficient and silent thermal dissipation
- Incredibly resistant and built for to face all kinds of challenges



## VERY HIGH-QUALITY COMPONENTS

The ACUTE series features the best components on the market

- Titanium diaphragm, high-class components: the Acute speakers are so precise and so powerful you can actually feel sounds.
- Oversized voice coil, die cast aluminium frame
- Electronic equalizer.

290

# ACUTE-08/AMP

100+50W bi-amplified active speakers

**A very compact speaker.**

**100W amplifier**

**+ 50 W HF amplifier**

ref 8738

- + 150 W RMS output
- + Bi-amplified
- + MIC/LINE input
- + Optional mounting bracket : SUP-AC08NO



- Removable fixation bracket
- Uses the M10 rigging points
- Can be vertically or horizontally oriented
- Max load: 10 kg

## ACCESSORIES

### SUP-AC08NO

Wall mount ACUTE 08 • Black version

ref 9598

Passive ABS speakers

# ACUTE PASSIVE SERIES

The ACUTE passive speaker series features 8 inches loudspeakers.

Their high-quality components fit in an ABS enclosure to make sure you get an exceptional sound quality for a reasonable weight.

Their incredible lifetime increases their adaptability: the ACUTE 08 are available with a white or a black finishing and a mounting bracket, or a mount pole thanks to their M6 mounting sockets.



+ 1 monitor-specific angle  
+ A crystal clear output  
+ A lot of mounting accessories available



## CREATED TO MEET YOUR NEEDS

The AUDIOPHONY know-how and high-quality components are gathered to meet your needs.

- The 12" and 15" models features a titanium membrane and a 50W RMS 1.75" driver
- Die cast aluminium frame and an oversized voice coil
- Passive filter created to ensure an intact sound balancing and an optimal protection



Acute in monitor mode



## HIGHLY ADAPTABLE

- Robust yet acoustics materials
- Use them as monitor speaker thanks to the monitor-specific angle and the rotating mount bracket
- Different finishing to match your hardware
- A whole range of wall mount accessories to adapt to all kind of shows.
- Many models are available (120 to 350W), for any kind of usage.

## ACUTE-08

120 W RMS ABS monitor  
**8" passive monitor**  
**power handling:**  
**120 W RMS**

ref 9596 white version and  
ref 9595 black version

- + Black or white finishing
- + Use them vertically or horizontally
- + 1.5"
- + Optional mounting bracket available



## ACCESSORIES

### SUP-AC08NO

Wall mount bracket for ACUTE 08  
**Black version**  
ref 9598

### SUP-AC08WH

Wall mount bracket for ACUTE 08  
**White version**  
ref 9599

- Removable mounting bracket
- Fix them directly onto the speakers
- Can be horizontally and vertically adjusted
- Max load: 10 kg

Installation speakers series

# S SERIES

The very best compact speakers can offer.

They are incredibly robust and will probably outlive many other speakers, and fit any kind of installation thanks to their brand new and very useful mounting bracket. But it's not over yet: available in black or white version for an even better adaptability, they produce an extremely clear, precise and balanced output, should it be playing instruments or voice.

Mounting bracket sold separately

- + New plywood cabinet
- + A whole range of wall mount accessories available
- + Magnificent black or white finishing



Find our **CB-210** and **EX15S** compatible subwoofers p.302



- + Power output: 250 W RMS
- + Astonishing rendering
- + Black or white finishing and mounting accessories available

- + Power output: 100 W RMS / 200 W peak
- + Very adaptable, compact format
- + Black or white finishing and mounting accessories available

- + Power output: 150 W RMS / 300 W peak
- + 1 monitor-specific angle
- + Black or white finishing and mounting accessories available

## S6

Satellite 100W RMS

S6 - Black version  
ref 9689

S6W - White version  
ref 9690

### TECHNICAL SPECIFICATIONS

- Plywood enclosure
- Finishing :
  - Black granite powder paint
  - Integral steel grill protection
  - 1 rear cut-away handle
- Frequency response (-3 dB) : 80 Hz - 20 kHz
- Power output : 100 W RMS / 200 W peak
- Impedance : 8 Ω
- Sensitivity 1 W/1 m : 93 dB / 118 dB peak
- Boomer : 6.5" die cast aluminium frame with 45 mm voice coil
- HF driver : 1" driver with 25 mm voice coil
- Horizontal dispersion : 90°
- Vertical dispersion : 60°
- Internal passive filter : cutoff frequency 2000 Hz
- Connectors : Speakon x 2 (1+1 - full range)
- Mounting socket for spacer pole
- Dimensions (L x W x H) : 222 x 365 x 205 mm
- Net weight : 6.5 kg

## S8

Satellite 150 W RMS

S8 - Black version  
ref 9691

S8W - White version  
ref 9692

### TECHNICAL SPECIFICATIONS

- Plywood enclosure with a monitor-specific angle
- Finishing :
  - Black granite powder paint
  - Integral steel grill protection
  - 1 cut-away handle
- Frequency response (-3 dB) : 80 Hz - 19 kHz
- Power output : 150 W RMS / 300 W peak
- Impedance : 8 Ω
- Sensitivity 1 W/1 m : 94 dB / 121 dB peak
- Boomer : 8" die cast aluminium frame with 50 mm voice coil
- HF driver : 1" driver with 44 mm voice coil
- Horizontal dispersion : 50 or 100°
- Vertical dispersion : 55°
- Internal passive filter : cut-off frequency 2100 Hz
- Connectors : Speakon x 2 (1+1 - full range)
- Mounting socket for spacer pole
- Dimensions (L x W x H) : 280 x 420 x 233 mm
- Net weight : 10 kg

## S10

Satellite 250 W RMS

S10 - Black version  
ref 9693

S10W - White version  
ref 9694

### TECHNICAL SPECIFICATIONS

- Plywood enclosure with a monitor-specific angle
- Finishing :
  - Black granite powder paint
  - Integral steel grill protection
  - 1 cut-away handle
- Frequency response (-3 dB) : 75 Hz - 19 kHz
- Power output: 250 W RMS / 500 W peak
- Impedance : 8 Ω
- Sensitivity 1 W/1 m : 96 dB / 126 dB peak
- HF driver : 10" die cast aluminium frame with 65 mm voice coil
- HF driver : 1" driver with 44 mm voice coil
- Horizontal dispersion : 50 or 100°
- Vertical dispersion : 55°
- Internal passive filter : cut-off frequency 2600 Hz
- Connectors : Speakon x 2 (1+1 - full range)
- Mounting socket for spacer pole
- Dimensions (L x W x H) : 320 x 530 x 280 mm
- Net weight : 14.5 kg

## ACCESSORIES

Mounting brackets



### SUPS6/NO

For S6 satellite - black  
ref 9705

### SUPS6/WH

For S6 satellite- white  
ref 9706

### SUPS8/NO

For S8 satellite - black  
ref 9707

### SUPS8/WH

For S8 satellite- white  
ref 9708

### SUPS10/NO

For S10 satellite - black  
ref 9709

### SUPS10/WH

For S10 satellite- white  
ref 9710



# MOJ500LINE

Le système poids plume tout-puissant\*

\*The almighty featherweight sound system



by  **audiophony**<sup>®</sup>  
EQUIPMENTS

# MOJO500LINE

Active subwoofer and column system + mixer with 1 bluetooth® input

code 10529

- + 3-channel mixer with Bluetooth input
- + Wide-angle column
- + Beautiful vocals and good bass rendering

## THE ALMIGHTY FEATHERWEIGHT - 500 W

This new sound system will amaze you by its presence. We calculated the position of each driver in the column so that everyone around can enjoy your music.

Last but not least, the built-in compressor allows a best sound recording from your microphones and better performances.

The whole system is easy to transport as it only weighs less than 15 kg!



The very particular waveguide of this subwoofer allows a better bass rendering while ensuring lower sound levels.



Mic/Line input

Mic/Guitare Input

Aux/Bluetooth® inputs

HF and basses control

Link output  
(to transmit the signal to another MOJO500Line)

## POWERFUL, ORIENTED SOUND IN A SMALL FORMAT

We precisely positioned the column speakers so they would allow a 120° horizontal dispersion and 20° vertical dispersion.

This asymmetrical diffusion allows sound reflections and enhance rendering, even for the most difficult configurations.



### COLUMN

- Power : 100W RMS - 200W max
- Frequency response : 180Hz - 20KHz
- Max.SPL (@1m) : 116 dB
- Nominal impedance : 4 Ohms
- Loudspeaker : 6 x 2,75" large bande
- Dispersion : 120° x 20° (HxV)
- Connector : integrated within the base
- Dimensions : (80 x 80 x 830 mm) x2
- Net weight : 2,45 kg + 1,20 kg = 3,65 kg

### AMPLIFICATION

- Power : 150W RMS - 300W max
- Frequency response : 50 - 200Hz
- Max SPL. (@1m) : 116 dB
- Nominal impedance : 4 Ohms
- Boomer : 08 pouces
- Dimensions : 340 x 430 x 400 mm
- Net weight : 10,8 kg
- Bass stage : 1 x 150W RMS / Classe D - 4 Ohms
- Mid/high stage : 1 x 100W RMS / classe D - 4 Ohms





# MOJO1000FX

Envoyez du son et faites de l'effet\*

\*Send music, start partying





# MOJO1000FX

Active subwoofer and satellites system + multi-effect DSP and Bluetooth® input

**Whole system supplied with stand and cables**

code 10528

- + 3-channel mixer with Bluetooth® input
- + 8-effect DSP
- + Rich, powerful sound output



The whole system weighs less than 20 kilos and takes very little space in the booth of a car.



The Class D amplification module with limiter and 3-channel mixer have been directly integrated within the subwoofer. Its Bluetooth receiver as well as its 8 digital effect presets are more signs that the MOJO1000FX is the perfect system for small venues, live music, but also meetings, conferences...

## COV-MOJO 1000FX

**Protective cover with internal storage compartment**

ref 10350



### ACCESSORIES

- ▶ Protective cover for stands with inside stow Pocket for cables and straps to maintain speaker stands
- ▶ Insert with screw thread to ensure a better stand stability
- ▶ 8x Clips to maintain the cable against the speaker stand

### SATELLITE

- Power output : 80W RMS - 160W max
- Frequency response : 155Hz - 22KHz
- Sensitivity(1W@1m) : 93 dB
- Max. SPL (@1m) : 120 dB
- Nominal impedance : 8 Ohms
- Boomer : 4,75"
- Tweeter : 1" compression
- Dispersion : 90° x 45° (HxV)
- Connector : 1 x Jack
- Fixation system : 1 x M6 Insert and support with 18 mm baseplate
- Dimensions : 225 x 140 x 110 mm
- Net weight : 1,9 kg

### SUBWOOFER

- Power output : 350W RMS - 700W max
- Frequency response : 50 - 160Hz
- Sensitivity(1W@1m) : 90 dB
- Max. SPL (@1m) : 120 dB
- Nominal impedance : 8 Ohms
- Boomer : 10"
- Fixation system : 1 x 25 mm baseplate on top
- Dimensions : 345 x 450 x 400 mm
- Net weight : 14,5 kg

### AMPLIFICATION

- Low frequencies : 1 x 350W RMS / Class D - 4 Ohms
- Mid/highfrequencies : 2 x 80W RMS / Class D - 8 Ohms

### INPUTS

- CH1 : 1 x Combo XLR/Line Jack/Microphone
- CH2 : 1 x Guitar Jack/Microphone
- CH3 : 1 x Line Jack L/R + 1 x Auxiliary 3,5 stereo Jack + Bluetooth input

### OUTPUTS

- 2 x Jack for satellites
- DSP : Reverb Plate/ Plate2/Room/Room2/Hall/Hall2, Delay, Vocal doubler
- Level : Volume control for each channel
- FX : Effects level control for each channel
- Sub : Subwoofer volume control
- High/Low : Mid and low frequencies equalization



# COMPACT700

l'ensemble triphonique à emporter\*  
+ Compact, + Léger, + Puissant

\*The take-away triphonic system  
Smaller, Lighter, Stronger



# COMPACT700

Self-powered triphonic compact sound system

**The 2.1 sound reinforcement system**

ref 10136

The COMPACT700 is a triphonic system featuring two satellites and a subwoofer. It works on its own: the COMPACTSUB12A amplifies the whole system: you won't need to add anything else.



## ADAPTABLE

The COMPACT700 features 2 mic inputs with their own volume settings

- 2 satellites
- 1 COMPACTSub12A subwoofer
- Cables supplied
- Stands NOT supplied

### SATELLITES :

- Power output : 125 W RMS
- Frequency response : 80 Hz - 20 KHz
- Sensitivity (1 W@1m) : 93 dB
- Max SPL (@1m) : 116 dB
- Nominal impedance : 8 Ohms
- Boomer : 6.5"
- Tweeter : 1"
- Dispersion : 90° x 60°
- Connector : 1 x Speakon
- Dimensions : 213 x 373 x 218 mm
- Weight : 6 kg

- + 700W for only 35kg
- + A perfect balance across the full spectrum
- + 2 Mic and 1 line inputs

Supplied with cables  
Supplied without stands



# COMPACTSUB12A

Active subwoofer

**12" Active subwoofer with a Class D amplifier**

ref 10139



## TECHNICAL SPECIFICATIONS

Power output : 450 W RMS

Frequency response : 52 - 200 Hz

Sensitivity (1 W@1m) : 95 dB

Max SPL (@1m) : 125 dB

Boomer : 12"

Dimensions : 470 x 360 x 490 mm

Weight : 23.5 kg

### AMPLIFIER :

Low frequencies : 1 x 450 W RMS / class D

Mid/high frequencies : 2 x 125 W RMS / class D

Adjustable crossover from 80 - 200 HZ

High-pass satellite filter : 22-80-125 Hz

Bass/Treble settings: +/- 10dB

L/R balance settings

Subwoofer phase switch and ON/OFF limiter switch

Sub and Master adjustable output .

Adjustable volume of the two mic inputs.

Connectors :

- 2 x XLR and 2x RCA line inputs

- 2 x jack mic input

- 2 x XLR line/output

- 2 x Speakon for the satellites

# COV-COMPACT700

Storage cover

**Storage cover for a whole COMPACT700 system**

ref 10144



299

**TRANSPORT SAFELY YOUR COMPACT700 WITH ITS UNIQUE COVER INCLUDING :**

- One cover for the subwoofer
- One cover for the two satellites
- One storage pouch for the cables (above the satellites cover)
- The subwoofer can be used within its cover.

# WHEELSPACK1

Set of 4 wheels

**Set of 4 wheels for COMPACT700**

ref 10140

# OCTAVE

Triphonic amplified system

High performances regardless the situation

ref 8969

# SUP OCT

Mounting bracket

**Black finishing**

ref 9605



- Removable wall mount bracket
- Uses the M10 rigging points
- Can be vertically or horizontally oriented
- Max load: 10 kg

- + 1000 W RMS system
- + Very powerful and comprehensive system
- + Built-in wheels to easily transport the subwoofer



## TECHNICAL SPECIFICATIONS

### 2 SATELLITES 1 SUBOCTAVE SUBWOOFER

Cables supplied

Stands NOT supplied

#### SATELLITES :

Power output : 200 W RMS

Frequency response : 80 Hz - 20 kHz

Sensitivity (1 W@1 m) 95 dB

Max SPL (@1 m) 120 dB

Nominal impedance : 8 Ω

Boomer : 8"

Tweeter : 1"

Dispersion : 90° x 60°

Connectors : 2 x Speakon

Dimensions : 420 x 265 x 240 mm

Weight : 9.5 kg

#### SUBWOOFER :

Power output : 600 W RMS

Frequency response : 40 - 200 Hz

Sensitivity (1 W@1 m) 99 dB

Max SPL (@1 m) 130 dB

Boomer : 15"

Dimensions : 545 x 450 x 635 mm

Weight : 45 kg

#### AMPLIFIER :

LF amplifier : 1 x 600 W RMS / class AB, 8 Ω

HF amplifier : 2 x 200 W RMS / class AB, 8 Ω

Connectors : 2 x XLR inputs

2 x XLR output/link

2 x jack/micro inputs

2 x RCA unbalanced outputs

2 x Speakon for the satellites

300

Please note: each satellite output has a 8 Ω minimum impedance. You can either plug 1x8 Ω satellite or 2x16 Ω satellites per output.

## COV-OCTAVE

Protective and transport cover

**Protective and transport cover for OCTAVE system**

ref 9556

One subwoofer cover

One satellites cover

The satellites cover can be fixed onto the subwoofer cover

One storage pouch for the cables (above the satellites cover)

The subwoofer can be used within its cover.





- + 1 active subwoofer: 600 W
- + Satellites amplifier supplied



# OCTAVE BASSE

600W powered 15" subwoofer with amplified satellite outputs  
**The Octave triphonic sound system**  
 ref 10003

## TECHNICAL SPECIFICATIONS

- |                                  |   |                                     |
|----------------------------------|---|-------------------------------------|
| • Power output : 600 W RMS       | • Dimensions : 545 x 450 x 635 mm               | • Connectors : 2 x XLR input        |
| • Frequency response : 40-200 Hz | • Weight : 45 kg                                | • 2 x XLR balanced link/output      |
| • Sensitivity(1 W@1 m) 99 dB     | AMPLIFICATION :                                 | • 2 x Jack micro                    |
| • Max SPL (@1 m) 130 dB          | • LF amplifier: 1 x 600 W RMS / Class AB, 8 Ω   | • 2 x RCA unbalanced input          |
| • Boomer : 15"                   | • HF amplifier : 2 x 200 W RMS / classe AB, 8 Ω | • 2 x Speakon to connect satellites |

Please note: each satellite output has a 8 Ω minimum impedance. You can either plug 1x8 Ω satellite or 2x16 Ω satellites per output.

# MTSUB12A

Amplified subwoofer - Bass reflex  
**The perfect way to optimise your 10" and 12" speakers**  
 ref 10078

|                        | MTSUB12A   |
|------------------------|--|
| Ref                    | 10078  |
| RMS output             | 400 W  |
| Max output             | 800 W  |
| Bass output            | 400 W  |
| Treble output          | -  |
| Amplifier class        | D  |
| Pre-amplification      | 1 XLR and RCA Line stereo input  |
|                        | XLR Line Out output  |
|                        | Volume control for each channel  |
|                        | Subwoofer cut-off frequency settings : from 80 - 180 Hz <ul style="list-style-type: none"> <li>• Low-pass filter (OFF-80-125) for satellites output</li> <li>• Phase inverter 0-180</li> </ul> |
| Housing                | Cubic housing with an integral protection grille   |
|                        | 1 top and 2 side handles   |
|                        | 36 mm socket for speaker stand (on top)  |
| Dimensions (H x W x P) | 469 x 489 x 360 mm   |
| Net weight             | 21.6 kg  |

- + Class D amplification
- + Stereo/mono XLR/RCA line input
- + Low-pass filter, and output signal filter
- + Light and compact – 21.6 kg



Rear

The MTsub12A offers precise, chestpounding basses at a 400 W RMS power output. It is compact, light and very resistant.

Its built-in active filter optimises the satellites output. Dedicated for installation and live performance.



## SRSUB18A

18 inches 600W RMS active Subwoofer with adjustable filter.

**A newcomer in the "SR" family**

ref 10713

- Power output: 600W RMS / 1200W max.
- Frequency response: 35 Hz - 150 Hz
- Filter cut-off frequency: de 60 à 150 Hz
- Settings:
  - Phase 0-180°
  - Volume
  - Cut-off frequency
- Max. SPL: 127 dB
- Woofer:
  - 18 inches
  - 4 inches coil
  - 8 Ohms - 800W
- Inputs: 2 Combo Jack/XLR inputs
- Outputs: 2 Balanced XLR outputs
- Protections: thermal and short-circuit protections
  - Class D amplifier with switched-mode power supply
- Dimensions: 770 x 680 x 560 mm
- Net weight: 39 Kg



## SRSUB15A

15 " 500W RMS self-powered subwoofer with adjustable filter

**A weighty addition to the SR series**

ref 10349

- Power output : 500W RMS / 1000W max.
- Frequency response : 40 Hz - 150 Hz
- Cutoff frequency : de 60 à 150 Hz
- Settings :
  - Phase 0-180°
  - Volume
  - Cross-over frequency
- SPL : 95 dB
- LF driver :
  - 15 "
  - 4 " coil
  - 8 Ohms - 800W
- Input :
  - 2 Inputs Combo Jack/XLR
- Output :
  - 2 Balanced XLR outputs
- Protection : SC,Th
  - Class D amplifier
  - SMPS
- Dimensions : 702 x 560 x 472 mm
- Net weight : 34 Kg



## CUBsub208

Passive subwoofer with 2 x 8" speakers.

**Discreet and compact format perfect for installations**

ref 10665

- Power output: 300W RMS - 600W max
  - Frequency response: 50Hz - 800Hz
  - Filter: does not feature any passive filter
  - Max. SPL (@1m): 124 dB
  - Nominal impedance: 4 Ohms
  - Boomer: 2 x 8" with 50mm coil
  - Connectors: via 2x speakon and In/Out via terminal
  - Material: Plywood housing and metal grille.
- Slot for coupling bar on top and rubber feet below and side inserts for wall fixation bracket.
- Black finish.
- Dimensions: 250 x 510 x 540 mm
  - Net weight: 18,5 kg



## CUBsub112

12" passive subwoofer

**Design bass reflex**

ref 10664

- Power output: 300W RMS - 600W max
  - Frequency response: 45Hz - 2,8KHz
  - Filter: does not feature any passive filter
  - Max. SPL (@1m): 125 dB
  - Nominal impedance: 8 Ohms
  - Boomer: 12" with 64 mm coil
  - Connectors: par 2x speakon et bornier pour In/Out
  - Material: Plywood housing and metal grille.
- Slot for coupling bar on top and rubber feet below.
- Black finish.
- Dimensions: 350 x 500 x 540 mm
  - Net weight: 20 kg

302



## CB-210

Installation passive subwoofer

**It rises to any challenge**

ref 9256

- Power handling : 300 W RMS / 600 W max.
- Frequency response (+/-3 dB) - 160 Hz
- Sensitivity (1 W/1 m) 96 dB
- Max SPL. : 127 dB
- Speakers : 2 x 26 cm - 50 mm voice coil
- Nominal impedance : 4 Ω
- Connectors : 2 x Speakon® NL4
- Mounting socket for spacer pole
- Dimensions (L x W x H) 400 x 650 x 445 mm
- Weight : 32 kg



## EX155

Touring passive subwoofer

**Extreme, house-shaking basses**

ref 9701

- Power handling : 600 W RMS / 1200 W max.
- Frequency response (+/-3 dB) : 50Hz - 200Hz
- Sensitivity (1 W/1 m) 99 dB / 132 dB SPL
- Max SPL. : 132 dB
- Speakers : 15" - Aluminium chassis - 100mm coil
- Nominal impedance : 8 Ω
- Connectors : 2 x Speakon® NL4
- Mounting socket for spacer pole
- Dimensions (L x W x H) 450 x 560 x 635
- Weight : 31 kg



# PORTABLE SOUND SYSTEM



# BOOMBOX

Bluetooth® speaker IP44

**Sound anywhere, enjoy everywhere**

Ref 10483



## INCREDIBLE MUSIC ALL DAY LONG

Discover the 2-way experience brought by the new BOOMBOX speaker. 60W of music within a compact and transportable format. Add a 10-hour battery on top of that, and you will get to enjoy your music extensively without charging it.



## TAKE IT EVERYWHERE

Weatherproof, super-light thanks to its lithium battery, BOOMBOX benefits from great autonomy and comfortable sound output, with built-in all-terrain trolley .



## WIRELESS WORLD

Bring your favourite music everywhere on your smartphone or tablet thanks to the wireless technology, and easily connect via Bluetooth. It is NFC compatible: all you need is getting your device close and it will automatically pair. Moreover, BOOMBOX features a 5 Volts, 2 Amps USB plug to charge your devices.







### LISTEN TO THE RADIO

Did you forget to bring your favourite tracks with you ? It is ok, BOOMBOX also features an FM receiver to listen to radio stations and save up your favourite 5.

### COLORFUL MUSIC

63 LEDs create light animations including 3 music-sensitive animations, 5 automatic animations and 1 « OFF » position.



### MAKE YOURSELF HEARD

BOOMBOX features two Jack 6,35 mm inputs to connect your guitar and microphone. If you cannot connect wirelessly, we got you: a USB reader and auxiliary plug are integrated to the speaker.

## COV-BOOMBOX

Protective cover for Boombox  
ref 10488



- Operating range of 10 m (average)
- Bluetooth® V2.1 + EDR with AVRCP profile to ensure CD quality tracks
- Sources : Bluetooth®/FM/Aux/Microphone/Guitar/USB
- IP level: IPX44
- Weight: 6 kg
- LED Indicator
- Battery indicator
- Guitar
- Power/Standby



- Control buttons
- 5 buttons to save radio stations
- Volume control, previous and skip buttons
- Power, Source, Bluetooth pairing
- Play/Pause, front lights animation selection
- USB 5V 2A output to charge your phone
- USB Mass storage plug. Allows you to play mp3 files from our USB key
- Mic/Guitar input via Jack 6.35
- Aux input via mini Jack 3.5 mm
- Bluetooth® NFC technology Class 2



# BRICK 120

La mini enceinte bluetooth  
à l'épreuve des bombes\*

\*It is bomb-proof





# BRICK120

Bluetooth® Hifi IP5X speaker

**Waterproof and shock-absorbent**

ref 10216

The weatherproof Brick120 is the companion you can take everywhere with you. Play your music for 10 hours via your smartphone or any Bluetooth® device, and enjoy the hands-free kit function.

- + Weatherproof
- + Bluetooth® NFC functions
- + 10 hours+ playtime

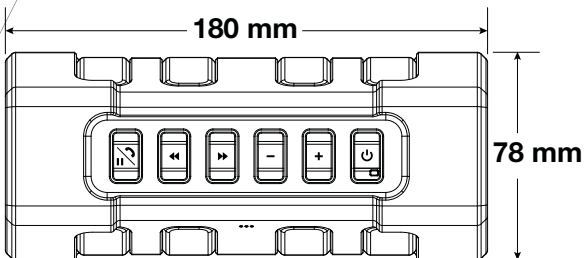
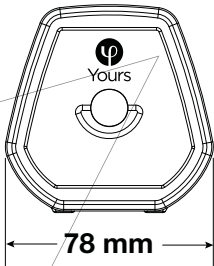

## HIGH SOUND QUALITY

The Brick120 uses the latest Bluetooth® protocols to offer you the best audio quality of the moment.

## EASY AND FAST PAIRING

Thanks to the new NFC technology, you only need to approach your phone (or any Bluetooth® device) in a 10cm perimeter and the two devices will automatically communicate.

- \*Easy NFC pairing allowing you any compatible device to communicate with the BRICK120 (smartphones, bluetooth devices...). Put the two devices together (in a 10cm perimeter) and they will automatically communicate.
- V4.0 AVRCP Bluetooth®, CSR compression and APT-X working altogether to produce a close-to-digital audio transmission
- Wireless range: approximately 10 meters - Class 2 Bluetooth®
- Control buttons : ON/OFF, BT volume, Play-pause, previous/next song and a battery indicator
- Input : V4.0 Bluetooth® connexion
- 10 hours+ playtime

- Charge the battery in less than 2 hours with the supplied AC
- Lithium 3600mAh battery
- 2x Neodymium speakers for clear medium/high frequencies + 1 Woofer for good quality basses
- Power output 20W
- Frequency response 70Hz-18KHz
- IP level : IPX5 (weatherproof)
- Dimensions : 180x80x80 mm
- Weight : 650 g

# BoraBora

Le son 360° en plein air\*

\*Outdoor music at 360°





# BoraBora

Outdoor portable speaker

**Set your music free**

ref 10174



## SHARE 360° MUSIC ANYWHERE YOU GO.

Bora Bora is an independent, outdoor and indoor mobile speaker.

 **Bluetooth®**



Batterie life  
**8h**



**NFC**  
compatible



Charge time  
**2h**



**360°**  
Diffusion



Weatherproof



Output  
**60W RMS**



Aux  
input

## TECHNICAL SPECIFICATIONS

- Power output 60W RMS
- 4x 2", 5W speakers :  
- 1x 5", 40W speaker
- V4.0 AVRCP Bluetooth®, CSR compression, APT-X
- Wireless range: 10 m - Class 2
- NFC Compatible - easy pairing
- Auxiliary input: Stereo 3.5 Mini-Jack
- Control buttons :  
- Power  
- Volume +/-  
- Bluetooth® pairing  
- Battery indicator
- Battery life: 8 hours
- Charge the battery in only 2 hours
- Lithium 14.8 V 2600mA battery
- Frequency response : 60Hz-15kHz
- Max SPL at 1 m : 95 dB
- IP level : IPX5 (weatherproof)
- Weight : 2.9 KG
- Dimensions : Diam 195 x 370 mm

## **Bluetooth™**

BoraBora is fully compatible with any Bluetooth® device and the NFC technology allows it to be automatically connected by simply approaching a Bluetooth® device close to it. The Aux input can be used to connect other non-Bluetooth® sources.

### 8 HOURS OF SERENITY

BoraBora only needs a 2-hour charge to play music for 8 hours. It can also operate with a power supply thanks to the supplied adapter.

### A DEEP BREATH OF FRESH AIR

BoraBora is weatherproof, and spreads your music through a 360° angle to remain at the heart of all attention.

Systems

# JOGGER

## 2 ULTRA PORTABLES SYSTEMS FOR CONFERENCES.

The JOGGER systems are designed to be moved around. They hang comfortably over your shoulder or are pole-mountable. This is what nomad installations and small meetings need.

The unique high-capacity battery works for several hours for a very short charging time. The carrying bag is an ideal feature to protect the JOGGER and transport all their accessories.

- + Powerful and clear output
- + Light and compact (less than 3 kg)
- + The battery lasts several hours

JOGGER**50**



310

JOGGER**60**



# JOGGER50

50 Watts self-powered system with a built-in USB reader and a UHF microphone

**Heard loud and clear everywhere**

ref 9587



The JOGGER50 features a 50 Watts RMS amplifier and a broadband loudspeaker. That means you will always be heard loud and clear. It is very handy and very light: it only weights 2.2 kg. The microphone can be pole mounted on any standard microphone stand.

## JOGGER 50 SUPPLIED WITH

- A USB reader
- A UHF handheld microphone
- A carrying bag
- A lithium battery and an adaptater for the power supply

# JOGGER60

60 Watts 2-way self-powered system with built-in USB/SD reader. Supplied with UHF and wired microphones

**Compact system designed for conferences and professional animations**

ref 9894



It weights only 2.9 kg, but features a built-in USB/SD media player, an AUX input, 1 wired and 1 UHF microphones. Its 2-way sound diffusion system generates a clear, precise and powerful music or vocal output.

## JOGGER 60 SUPPLIED WITH

- A USB/SD reader
- A UHF handheld microphone
- A wired handheld microphone
- An infrared remote control
- A carrying bag
- A lithium battery and an adaptater for the power supply

## ACCESSORIES for JOGGER

# LT POW

Charger for 260 mA batteries  
ref 9591



The JOGGER systems feature an AC adapter, but the LTPOW charger allow you to charge an extra battery independently. Because we should never put all our eggs in one basket.

# LT 2600

Extra 260 mA battery  
ref 9592



The JOGGER systems are supplied with their own battery, but this extra battery will be of precious help in case of emergency.



# CR12A-COMBO

Le renouveau de la sonorisation tout-terrain\*

\*The future of off-road systems





# CR12A COMBO

Battery-operated self-powered system

**An off-road system**

ref 10209

## THE CR12A-COMBO IS A SUPER-POWERFUL PORTABLE SOUND SYSTEM WHICH FITS ANY NOMAD INSTALLATION..

It features a USB/SD player, a Bluetooth® receiver, two UHF wireless microphones, an external source and a mixer allowing you to connect 2 extra microphones. It is complete, very easy to use and super powerful. On top of that, it is also easy to transport and very handy thanks to its built-in transport trolley, and its outstanding battery life. It fits in small spaces, and you can store every device you need inside its storage compartments.

- + All-in-one and easy to transport
- + Great performance and sound quality
- + Media player and 2 UHF microphones



**Bluetooth™**

Supplied with 2 handheld microphones and batteries.



### TECHNICAL SPECIFICATIONS

Loudspeaker : 10" + 1" driver

Power output : 120 W RMS Class D amplifier

Impedance : 4 Ohms

HF Mic : UHF with 16 frequencies

Frequency band : UHF 863-865 Mhz

Player : USB + SD card reader

Infrared remote control with the main functions and volume control

1 Bluetooth® built-in receiver

Inputs :

CH1 : Line in via RCA

CH2 : MIC/LINE via Combo XLR/Jack

CH3 : MIC/LINE sur Combo XLR/Jack

Line output via Jack

Settings:

- Player and CH1 volume

- CH2 and CH3 volume

- UHF microphone receivers volume

- Master volume

- Low and mid frequencies volume

Battery life : approximately 6 hours - depending on the volume

Charge time :

- 8 hours for both 12 V batteries

Batteries :

- 2x12V / 5Ah

Power management :

- A LED screen indicates the battery charge level

- Charge and use it simultaneously

- Automatically shut downs when the battery level is too low

Accessories :

- Storage compartment for 2 mic and cables

- Retractable grip and built-in wheels

- Supplied with 2 UHF handheld microphones

- Headband microphone (optional)

Finishing :

- Polypropylene housing

- Steel mesh grille

- C36 socket to pole mount it

Dimensions : 550 x 340 x 300 mm

Net weight (including batteries) : 17.3 kg

## CR12A HEADSET

Optional UHF bodypack transmitter and headband microphone. Can replace the CR12A-COMBO handheld microphone

ref 10210



## COVER CR12A

Cover for speaker CR12ACOMBO

ref 10208



# CR120A-U1

120 W portable speaker with Bluetooth®, USB player and 1 UHF microphone

**An adaptive portable sound system**

ref 10285

The CR120A-U1 is an all-in-one portable sound system. It comes with a USB/SD reader, a Bluetooth® receiver, a UHF handheld microphone and a very complete mixer to add external sources. The CR120A-U1 features storage compartments, which makes it perfect to pack away the UHF microphone and many accessories available. It is very efficient, easy to use and delivers a powerful, clear sound output.

Its infrared remote control gives you an immediate access to main functions. Its built-in trolley makes transport easier and two extra batteries can also be added to make it a fully transportable system.

+ Complete sound system with 1 UHF handheld microphone and a MP3 + Bluetooth® player  
+ Exquisite sound output  
+ Optional extra batteries



Compatible CR12A headset



Batteries not supplied

Optional battery  
Battery 12V 5Ah NP  
2 batteries for CR120A-U1  
Ref Z08118

## COVER CR12A

Protective cover for CR12A-COMBO speaker  
ref 10209



**TECHNICAL SPECIFICATIONS**

Loudspeaker : 10" x loudspeaker + 1" titanium driver, total impedance: 4 Ohms  
Power output : 120W RMS / 240 max Class D amplifier  
Frequency response : 55 - 20k Hz  
SPL : 118 dB SPL max  
1 UHF microphone :  
- UHF Diversity with 16 frequencies  
- Handheld cardioid-dynamic microphone (infrared synchronisation)  
Frequency range : UHF 863-865 Mhz - 10 mW  
Player :  
- Built-in USB key / SD card reader and Bluetooth® receiver  
- Supplied with an infrared remote control

Bluetooth® :  
- The player features a Bluetooth® receiver  
- Type V2.0 AVRCP, with an excellent, close-to-digital audio transmission  
Finishing : Polypropylene housing, metal mesh grill. C36 mounting plate for speaker stands.  
Dimensions mm : 500 x 340 x 300  
Net weight (with batteries) : 17.3 kg  
**EXTRA BATTERIES**  
- 2x 12V / 5Ah LA  
- Dimensions (width x height x depth): 90x100x70 mm

# CR80 ACOMBO

80W portable speaker Bluetooth® compatible, with a USB player and 1 UHF microphone

**Small outside, big inside**

ref 10313

- + Portable sound system with a microphone and MP3 + Bluetooth® player
- + Supplied with Lithium-ion batteries
- + Light and compact



## COVER CR80A

Cover for CR80A-COMBO speaker  
ref 10431



### TECHNICAL SPECIFICATIONS

Loudspeaker: 6.5" loudspeaker + 1" titanium driver, total impedance: 4 Ohms

Power output : 80W RMS / 160 max Class D amplifier

Frequency response: 65 - 18 kHz

SPL: 110 dB SPL max

UHF microphone:

- UHF diversity
- Handheld dynamic cardioid mic

Fixed frequency: UHF range: 863-865 Mhz - 10 mW

Reader :

- USB/SD reader and Bluetooth® receiver
- Supplied with an infrared remote control

Bluetooth® :

- The player features a Bluetooth® receiver
- Type V2.0 AVRCP, with an excellent, close-to-digital audio transmission

Finishing : Polypropylene housing, metal mesh grille. C36 mounting plate for speaker stands.

Dimensions en mm : 375 x 240 x 210

Net weight (including the batteries) : 5.9 kg

#### BUILT-IN BATTERIES

Batteries: 2x12v DC 1,5AH Lithium-ion

Battery life: approximately 5 hours

Charging time: Approximately 6 hours to charge both batteries

Power supply management :

- Visualise the battery level via a LCD display. Charge and use it simultaneously.
- Automatically shutdowns when the battery level is too low.

## CR80-HEADSET

Transmitter + headband microphone for CR80A-COMBO speaker  
ref 10534



Systems

# SPRINTER

**VERSATILITY, POWER AND QUALITY. IT SIMPLY DOES EVERYTHING VERY WELL.**

One at first assumes it simply is a super-powerful, multi-functional system. Everybody can hear it produces an incredible 120W power output as performing with voices as with music. Careful observers might also notice the integrated wheels, supplied protective cover and incredible robustness of the SPRINTER systems. But when you look under the hood you will be amazed by the many storage spaces, the 10" loudspeaker and 1" driver, and the two extra-batteries allowing a several hours performance. If you really want to try to wear it down it will bring in reinforcements: 2 UHF microphones and 2 wired microphones, a cassette player or a USB/CD/SD player, or even a single USB player. The SPRINTER represents off-road raw power and precision within a mobile speaker adapted to your nomad installations.



+ Warm, clear and powerful output  
+ Many storage compartments  
+ Long-life battery for several hours performance

## ACCESSORIES Sprinter

### PASSPRINT

120W passive speaker  
ref 9983

See page 264



### RUN-K7

Cassette playing/recording module  
ref 8206

- Logic control deck
- Player and recorder with auto-reverse
- Pitch control
- Level and recording controls with metering on the LCD display (for SPRINTER only)
- Use to digital display to keep track of your recording



316

### COV-SPRINT

Protective cover for SPRINTER systems.  
ref 9986

- Use the speaker within its cover
- Compatible with the whole SPRINTER series products.







# SPRINTER ONE-V122

120 Watts self-powered system  
**No-option version**  
ref 9977

## THE SPRINTER-ONE VERSION FEATURES A WHOLE SPRINTER SYSTEM

- 120 Watts amplifier
- Full preamplification
- Protective cover
- Built-in transport trolley
- 2x12-volt batteries
- A power cord

The SPRINTER-One can benefit from all of the SPRINTER-compatible options (within the limits of available storage compartments.) See pages 264-265



# SPRINTER122

120 Watts self-powered system - Built-in CD/MP3/USB/SD player and UHF microphones SPRINTER122  
**Best-seller version**  
ref 9837



Back and front infrared sensor.

Adjust the playing speed via the remote control.



## THE SPRINTER122 VERSION FEATURES A WHOLE SPRINTER SYSTEM

- 120 Watts amplifier
- Full preamplification
- Protective cover
- Built-in transport trolley
- 2x12 V batteries
- A power cord/charger

## IT ALSO FEATURES BUILT-IN FUNCTIONS

- The player is delivered loose and has to be mounted in.
- 2 front/rear infrared sensors
- One UHF microphone

A second UHF microphone and an extra speaker (PASSPRINT) can also be added. (See pages 264-265)

For illustration purposes only. The CD player and the microphone receiver are not supplied with the speaker.

The Bluetooth® trademark and logo are registered by the Bluetooth SIG, inc.

Systems

# CROSSER

## SUPER-POWER ON WHEELS.

The CROSSER is mobile and incredibly powerful. Its 10" loudspeaker combined to a 1.5" driver produces a very high-quality sound for such a compact sound system. Choose your configuration and options to make it the best performance companion, for hours of free sound.



- + Warm, clear and powerful output
- + Many storage compartments
- + Long-life battery for several hours performances

## ACCESSORIES Crosser

### PASSCROSS

180W passive speaker  
ref 9984

### COV-CROSS

Protective cover for CROSSER systems  
ref 9985



See page 320



- Use the speaker within its cover
- Compatible with the whole CROSSER series

318



# CROSSER ONE-V180

180 Watts self-powered system  
**No-option version**  
ref 9978

## THE CROSSER-ONE VERSION FEATURES A WHOLE CROSSER SYSTEM :

- 180 Watts amplifier
- Full preamplification
- Protective cover
- Built-in transport trolley
- 2x12 V batteries
- A power cord

The CROSSER-One can benefit from all of the CROSSER-compatible options (within the limits of available storage compartments.) See pages 264-265

# CROSSER180

180 Watts self-powered system - Built-in CD/MP3/USB/SD player and UHF microphones CROSSER180  
**Best-seller version**  
ref 9895



Back and front infrared sensor.

Adjust the playing speed via the remote control.



## THE CROSSER180 VERSION FEATURES A WHOLE CROSSER SYSTEM :

- 180 Watts amplifier
- Full preamplification
- Protective cover
- Built-in transport trolley
- 2x12 V batteries
- A power cord/charger

## IT ALSO FEATURES BUILT-IN FUNCTIONS

- The player is delivered loose and has to be mounted in.
- 2 front/rear infrared sensors
- One UHF microphone

You can also add a second UHF microphone and an extra speaker (PASSCROSS). (See pages 264-265)

For illustration purposes only. The CD player and the microphone receiver are not mounted in the speaker.

The Bluetooth® trademark and logo are registered by the Bluetooth SIG, inc.

# PORTABLE SOUND SYSTEMS ACCESSORIES

YOU CAN ADD MANY ADDITIONAL MODULES TO THE RUNNER, SPRINTER AND CROSSER SYSTEMS TO FIT YOUR EVERY NEED.



## PASSCROSS

Passive 180 Watts speaker  
ref 9984

- 1.5" driver and 10" loudspeaker
- The PASSCROSS speaker allows you to add another source and spread music more efficiently
- ABS enclosure and steel grill
- Microphone and cables storage compartment
- Same dimensions as the CROSSER
- 36mm pole mounting socket
- 6.35 Jack input
- Supplied with a protective cover

## PASSSPRINT

Passive 120W speaker  
ref 9983

- 10" loudspeaker and 1" driver
- The PASSSPRINT speaker allows you to add another source and spread music more efficiently
- ABS enclosure and steel grill
- Microphone and cables storage compartment
- Same dimensions as the SPRINTER
- 36mm pole mounting socket
- 6.35 Jack input
- Supplied with a protective cover





## EMET-HEAD

Headband microphone

**Pocket UHF transmitter and headband microphone for a RECEPT-MOD16 receiver**

ref 9981

- Unidirectional headband condenser microphone
- UHF transmitter with adjustable volume
- 16 different frequencies
- Frequency response : 100 - 16 kHz +/- 3 db
- Power output : 10 mW
- Operates with 2 1.5V Type AA batteries (not supplied)
- The EMET-HEAD requires a slot-in receiver. Compatible with the RUNNER, SPRINTER, CROSSER and JOGGER.



## EMET-HAND

Handheld UHF microphone transmitter

**Handheld UHF microphone and transmitter for a RECEPT-MOD16 receiver**

ref 9980

- Dynamic handheld UHF microphone
- 16 different frequencies
- Frequency response : 50 - 18 kHz +/- 3 db
- Power output : 10 mW
- Operates with 2 1.5V Type AA batteries (not supplied)
- The EMET-HAND requires a slot-in receiver. Compatible with the RUNNER, SPRINTER, CROSSER and JOGGER.



## RECEPT-MOD16

Slot-in UHF receiver module

**UHF receiver for a EMET-HAND or EMET-HEAD transmitter**

ref 9979

- Slot-in UHF receiver module with adjustable volume
- 16 different frequencies
- Volume settings
- Signal input/output LED indicator
- The RECEPT-MOD16 requires an available receiver slot in your portable audio system . Compatible with the RUNNER, SPRINTER, and CROSSER.



## USB-RUN

USB player

**Double slot USB reader**

ref 9982

- Play/Pause/Skip/Eq/Repeat/Stop
- Compatible with MP3 and WMA files
- Access the volume settings from the front panel
- Toolless connexion thanks to the intuitive connectors
- The USB-RUN requires an available double-slot in your portable audio system.
- Compatible with the RUNNER, SPRINTER and CROSSER



## CD-RUN BT

CD/USB/SD Bluetooth® module

**CD/USB/SD and sound system**

ref 10184

- Reads CDs, USB keys and SD cards
- V2.0 AVRCP Bluetooth®
- Wireless range: approximately 10 m - Class 2 Bluetooth®
- Adjustable playing speed +/- 10%
- Play/Pause/Skip/Eq/Repeat/Stop/ Random/Folder/
- Compatible with MP3 and WMA files
- Infrared remote control
- Toolless connexion thanks to the intuitive connectors
- The USB-RUN requires an available double-slot in your portable audio system.
- Compatible with the RUNNER, SPRINTER and CROSSER



## RUN-K7

Cassette player and recorder

ref 8206

- Logic control deck
- Player and recorder with auto-reverse
- Pitch control
- Level and recording controls with metering on the LCD display (for SPRINTER only)

Portable Series

# TECHNICAL



|                                       | <b>JOGGER 50</b>  | <b>JOGGER 60</b>   | <b>CR80A-COMBO</b>   |
|---------------------------------------|---|--|--|
| <b>REF</b>                            | 9587  | 9894   | 10209  |
| <b>Power output</b>                   | 50 W  | 60 W (2-way)   | 120 W RMS  |
| <b>Loudspeaker</b>                    | 5"  | 5" + 1" driver'  | 10"  |
| <b>Supplied microphone</b>            | UHF handheld microphone   | UHF handheld and wired microphones   | 2 UHF handheld microphone + receiver   |
| <b>UHF microphone available slots</b> |   |  | -  |
| <b>Source</b>                         | USB/MP3 player  | USB/SD/MP3 player  | USB/SD + Bluetooth® player   |
| <b>Available player slots</b>         |   |  | -  |
| <b>Inputs</b>                         | 1 Aux in, 1 Mic in  | 1 Aux in, 1 Mic in   | 2 RCA Line IN<br>2 XLR/JACK MIC/LINE   |
| <b>Outputs</b>                        | 1 Mix Out   | 1 Mix Out  | 1 JACK line  |
| <b>Battery</b>                        | Lithium 14.4V 2.6Ah   | Lithium 14.4V 2.6Ah  | 2 x 12V / 5Ah LA   |
| <b>Autonomy</b>                       | Approximately 4 hours   | Approximately 4 hours  | Approximately 6 hours  |
| <b>Weight</b>                         | 2.2 kg  | 2.9 kg   | 17.3 kg (sans batteries)   |
| <b>Supplied accessories</b>           | Messenger bag<br>Lithium battery<br>AC adapter<br>UHF handheld microphone | Messenger bag<br>Lithium battery<br>AC adapter<br>UHF handheld microphone-<br>Wired microphone<br>Remote control | Infrared remote control  |
| <b>Optional accessories</b>           | Additional battery<br>External battery charger                            | Additional battery<br>External battery charger   | COV-CR12A<br>Protective cover<br><br>CR12A-HEADSET<br>UHF bodypack receiver and headband microphone<br><br>Extra batteries |
| <b>Recommended passive speaker</b>    |   |  | -  |

Portable sound system / Portable Speakers



|                                       | <b>CR12A-COMBO</b>                   | <b>CR120A-U1</b>   | <b>SPRINTER ONE-V122</b>   | <b>SPRINTER 122</b>  | <b>CROSSER ONE-V180</b>  | <b>CROSSER 180</b>   |
|---------------------------------------|--------------------------------------|--|--|--|--|--|
| <b>REF</b>                            | 10313                                | 10285  | 9977   | 9837   | 9978   | 9895   |
| <b>Power output</b>                   | 80 W RMS                             | 120 W RMS  | 120 W (2-way)  | 120 W (2 voies)  | 180 W (2 voies)  | 180 W (2 voies)  |
| <b>Loudspeaker</b>                    | 6.5"                                 | 10"  | 10" + 1" driver  | 10" + 1" driver  | 10" + 1.5" driver  | 10" + 1.5" driver  |
| <b>Supplied microphone</b>            | 1 UHF handheld microphone + receiver | 1 UHF handheld microphone + receiver   |  | Supplied with 1 UHF handheld microphone + receiver   |  | Supplied with 1 UHF handheld microphone + receiver   |
| <b>UHF microphone available slots</b> | -                                    | -  | 2 slots  | 1 slot   | 2 slots  | 1 slot   |
| <b>Source</b>                         | USB/SD + Bluetooth® player           | USB/SD + Bluetooth® player   |  | CD/USB/SD/MP3 player + pitch + Bluetooth®  |  | CD/USB/SD/MP3 player + pitch + Bluetooth®  |
| <b>Available player slots</b>         | -                                    | -  | 1 CD-RUN or USB-RUN slot 1 RUN-K7 slot   |  | 1 CD-RUN or USB-RUN slot   |  |
| <b>Inputs</b>                         | 2 RCA Line IN<br>2 XLR/JACK MIC/LINE | 2 RCA Line IN<br>2 XLR/JACK MIC/LINE   | 2 Line in, 2 Mic In  | 2 Line in, 2 Mic In  | 2 Line in, 2 Mic In  | 2 Line in, 2 Mic In  |
| <b>Outputs</b>                        | 1 JACK line                          | 1 JACK line  | 1 Mix Out, 1 HP Out  | 1 Mix Out, 1 HP Out  | 1 Mix Out, 1 HP Out  | 1 Mix Out, 1 HP Out  |
| <b>Battery</b>                        | 2x DC12V 1.5AH Li-ion                | 2 x 12V / 5Ah LA (en option)   | 2 x 12V / 4.5Ah NP   | 2 x 12V / 4.5Ah NP   | 2 x 12V / 5Ah NP   | 2 x 12V / 5Ah NP   |
| <b>Autonomy</b>                       | Approximately 5 hours                | Approximately 6 hours  | Approximately 6 hours  | Approximately 6 hours  | Approximately 7 hours  | Approximately 7 hours  |
| <b>Weight</b>                         | 5.9 kg                               | 17.3 kg (without batteries)  | 14 kg  | 15 kg  | 16 kg  | 17 kg  |
| <b>Supplied accessories</b>           | Infrared remote control              | Infrared remote control  | Carrying bag<br>Built-in wheels<br>Battery charger   | Carrying bag<br>CD/USB/SD/MP3 player + pitch<br>UHF handheld microphone<br>Built-in trolley<br>Battery charger<br>Remote control | Carrying bag<br>Built-in trolley<br>Battery charger  | Carrying bag<br>CD/USB/SD/MP3 player + pitch<br>UHF handheld microphone<br>Built-in trolley<br>Battery charger<br>Remote control |
| <b>Optional accessories</b>           | -                                    | COV-CR12A<br>Protective cover<br>CR12A-HEADSET<br>UHF bodypack receiver and headband microphone<br>Extra batteries | USB/SD/MP3 player+ pitch and remote control for USB MP3 player<br>Additional micro receiver<br>Additional UHF handheld mic<br>Additional UHF headband microphone<br>Passive speaker<br>Cassette player | Extra mic receiver<br>Extra UHF handheld microphone or UHF headband microphone<br>Passive speaker<br>Cassette player             | Extra mic receiver<br>Extra UHF handheld microphone or UHF headband microphone<br>Passive speaker<br>Cassette player | Extra mic receiver<br>Extra UHF handheld microphone or UHF headband microphone<br>Passive speaker<br>Cassette player             |
| <b>Recommended passive speaker</b>    | -                                    | -  | PASSSPRINT   | PASSSPRINT   | PASSCROSS  | PASSCROSS  |





**COMMERCIAL AUDIO,**

**GONE ARE THE DAYS OF THE ASCETIC PUBLIC-ADDRESSING !**

The « Commercial Audio » name takes on full significance with AUDIOPHONY PA. The refined aesthetic, the discretion and the incredible sound quality of our PA systems are endorsed by many smart and trendy places, but can also be used at home.

The "Commercial Audio" series gives you a high-quality technology to broadcast music or information in bars, shops, public areas, and more.

Let us not forget we also have very simple products, that can be used without any restraint outdoor or indoor. We are aware of your needs, and this is why we created AUDIOPHONY PA Commercial Audio.

# COMMERCIAL AUDIO SERIES



# ON THE TERRACE...

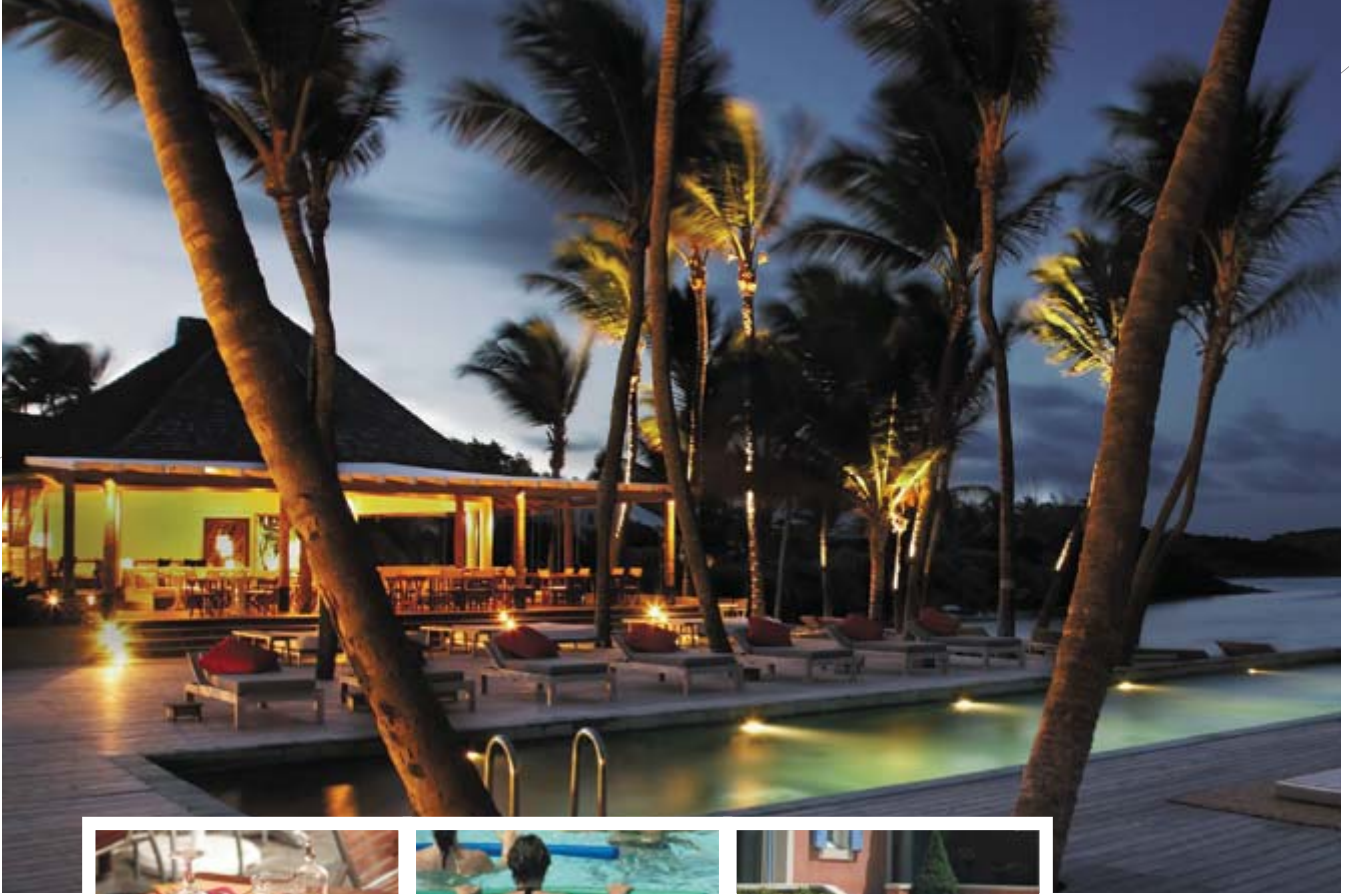

326

Bornéo  
page 331

The "Commercial Audio" series brings you adequate solutions for any outdoor installation and wet locations. Our solutions are able to create the mood anywhere with a powerful HiFi output. Integrate them to either mono or multi-source systems to use them indoor or outdoor.

Our tropicalized speakers benefit from a refined design, whereas the specific treatment of housings and loudspeakers guarantee a perfect fit in any installation, even in wet, complicated situations.





# COSILY...

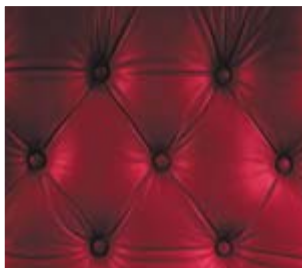
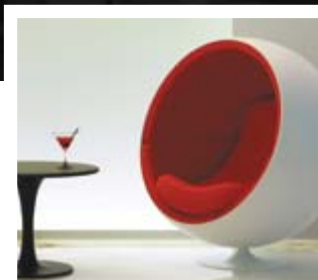

OHO-350W  
page 367

Subtle and elegant devices perfect for relaxation and party places. They are compatible with almost every audio device, and different models are available to perfectly suit your installation.

Each component has been designed so the speaker fully integrates your project or installation. Our famous speakers, recessed amplifiers and multimedia systems will meet even the most demanding installation standards.





# IN YOUR SHOP...

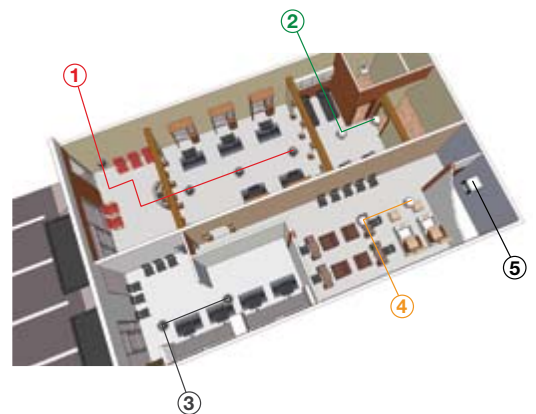

- 4 Zones
- 1 : Entry Hall+ barbershop with 4 CHP620
  - 2 : Massage area with 2 CHF860
  - 3 : Hairsalon with 2 CHP620
  - 4 : Beauty salon 2 CHF860
  - 5 :Wiring closet with the sources and amplifiers

Our very discreet and intuitive solutions made for commercial premises guarantee you an even sound distribution, a high-quality output at low volume and clear, intelligible voices. You will benefit of an excellent value for money principle for places combining announcements and music.

We provide you with a vast range of multiple broadcast with zone management devices to allow you to perfectly control every area.



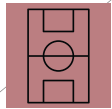

# PUBLIC SPACES...



Micdesk & Micdesk-4  
page 363 - page 367

You will benefit of an excellent value for money principle for places combining announcements and music. We provide you with a vast range of multiple broadcast technologies, with a zone management to allow you to perfectly control every area.

The "Commercial Audio" series provides you with many ways to implement an indoor or outdoor sound system. It has been designed to broadcast public announcements and background music with a constant quality and a high reliability.

We have a lot of knowledge of the industry, commercial and corporate sectors and we share it with you via a whole range of products putting yourself at the heart of a safe, simple and coherent sound system.

# SPREAD THE MUSIC



## A PERFECT SOUND QUALITY EVERYWHERE

Should it be indoor or outdoor, a background music is always welcome to work, party, or simply be in a good mood. That is why we have a very vast speakers selection fitting your every need. Sound quality, design, installation ...

Each project has its own criterias, and we have the speakers you need for it.



# BORNEO660

100V Tropical HiFi speaker

**This tropical speaker features an incredible finishing and a unique design**

Black version ref 9920    White version ref 9911



**HiFi**



- + High-quality 60 W output
- + Use it indoor or outdoor
- + Elegant, refined black or white housing
- + Very discreet holding system, can be vertically or horizontally oriented
- + Requires a low-impedance or a 100V line

## SPECIFICATIONS

- 2-way speaker
- RMS power output: 60 W
- Max power output : 200 W
- Available power outputs : 60 W/20 W/15 W/10 W/5 W
- 8 Ohms/100 V
- Tweeter : 25 mm (1")
- Boomer : 165 mm (6.5 ")
- Frequency response : 45 Hz – 20 kHz
- Sensitivity >89 dB
- External dimensions (diameter and depth) : 340 x 220 x 200 mm
- Net weight : 3.8 kg

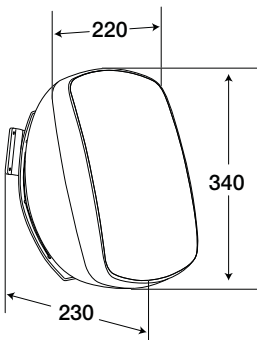

## HIFI QUALITY

The BORNEO660 produces an incredible, high-quality sound output even at full volume. It was designed for music lovers. It is weatherproof and can be operated in wet locations.

## OUR ADVICE

To optimise your BORNEO660 speakers, we recommend to combine it with the class D Ti300 or Ti154 Audiophony® amplifier.



# OHO-Systema-1b

Des bulles pour sonoriser l'espace\*

\*Sound bubbles from another dimension

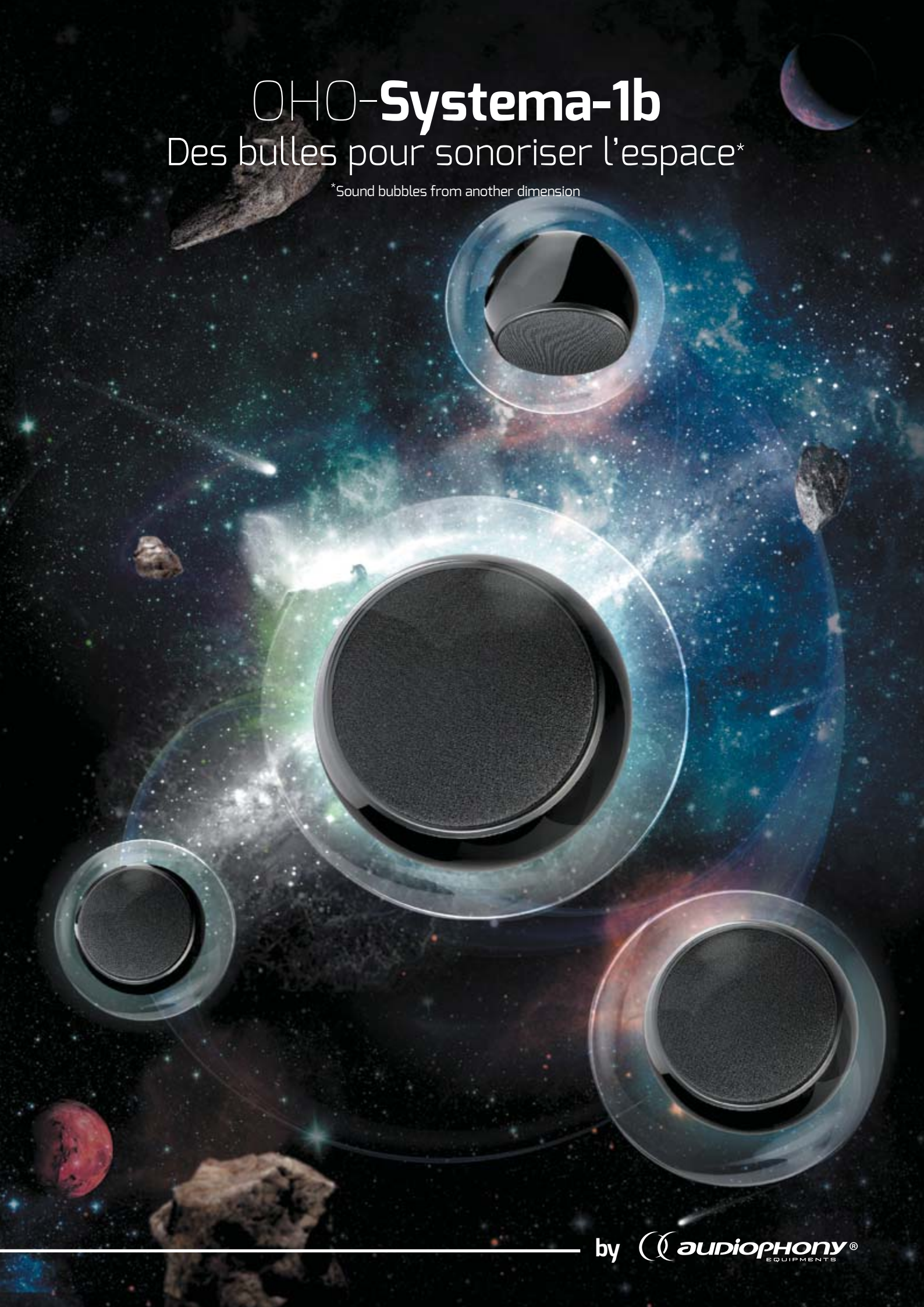



# OHO-350

8 Ohms HiFi speaker

**Compact satellite with a magnetised base**

Black version ref 10125    White version ref 10124

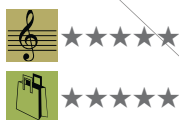

- + Powerful, spherical satellites
- + Sold in pairs

## SPECIFICATIONS

- Power output : 50 W RMS
- Frequency response : 100 Hz - 25 KHz
- Sensitivity (1 W@1m) : 89 dB
- Nominal impedance : 8 Ohms
- Boomer : 3"
- Tweeter : 1" compression
- Connector : Mount-integrated terminal
- Dimensions : Diam 115 mm
- Weight : 0.7 kg

## THE ORIENTATION YOU NEED

The very innovative magnetised base allows the OHO-350 to integrate any indoor installation, providing a pure, precise and soft background music.



# MIO-SAT 440b

80hms, 40W speaker

**Swivel-mounted wall speakers**

ref 10154



- + 80hms, 40W speaker
- + Designed to be used indoor
- + 2-way wooden speaker
- + Swivel-mounted compact satellites

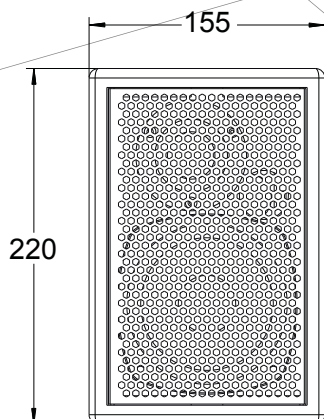

## SPECIFICATIONS

- Power output : 40 W RMS
- Frequency response : 120 Hz - 16 KHz
- Max SPL (@1m) : 116 dB
- Nominal impedance : 8 Ohms
- Boomer : 4"
- Tweeter : 1" compression
- Connector : Rear terminal
- Dimensions : 155×170×220 mm
- Weight : 2.6 kg

# MIO-SAT225b

80hms, 25W speaker

Wall speakers with a turnable holder

ref 10150



HiFi

The MIO-SAT225b fixation system integrates a small space designed for the wires. It is subtle and optimised to provide you with the best performances you can get.



- + 80hms, 25W speaker
- + Designed to be used indoor
- + Compact satellites with a turnable holder
- + The terminal is integrated within the holder

## SPECIFICATIONS

- Power output : 25 W RMS
- Frequency response : 200 Hz - 15 KHz
- Max SPL (@1m) : 110 dB
- Nominal impedance : 8 Ohms
- Boomer : 2X2.75"
- Connector : Mount-integrated terminal
- Dimensions : 90x136x180mm
- Weight : 0.950 kg

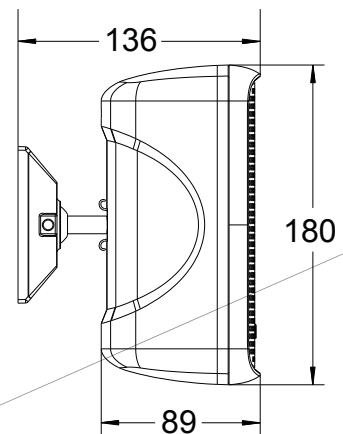

# EHP880b

80W HiFi speaker

**Versatile, powerful speaker**

ref 10212



**HiFi**

## HIFI OR 100 V

The EHP880 speakers can be used with a low impedance or a 100V line. They are absolutely perfect to broadcast voice or music, and fit any kind of installation: shops, conference rooms, waiting rooms, places of worship... The volume controller allows you to adjust it to your needs.



- + 80 W high-fidelity sound
- + Very discreet, black or white finishing
- + Built-in wall-mount bracket
- + Requires a low-impedance or a 100V line

### NOTE :

Not compatible with ROT45

336

### SPECIFICATIONS

- |   |  |
|---|--|
| <ul style="list-style-type: none"> <li>• Power outputs :<br/>- 20 or 40 or 80W at 100V<br/>- 10 or 20 or 40W at 70V<br/>- 50W into 8 Ohms</li> <li>• Power supply : 100 V/ 70 V or 8 Ohms</li> <li>• Impedances :<br/>125 or 250 or 500 Ohms<br/>or 8 Ohms low impedance</li> <li>• Components : 8" loudspeaker and 1" tweeter</li> </ul> | <ul style="list-style-type: none"> <li>• Sensitivity (1 M/1 W) : 92 dB</li> <li>• Frequency response : 70 Hz - 18 kHz</li> <li>• Material : ABS enclosure, steel grill</li> <li>• Holding system : Adjustable holding bracket</li> <li>• Connectors : 2-pin connector</li> <li>• Dimensions : 302 x 172 x 165 mm</li> <li>• Weight : 3.4 kg</li> </ul> |
|---|--|

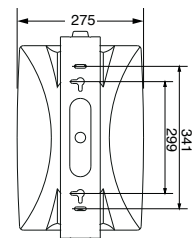
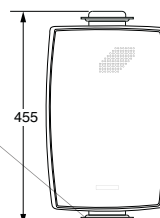
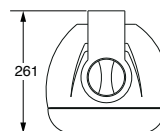



# EHP880w

80W HiFi speaker

**Versatile, powerful speaker**

ref 10213



**HiFi**



- + 80 W high-fidelity sound
- + Very discreet, black or white finishing
- + Built-in wall-mount bracket
- + Requires a low-impedance or a 100V line

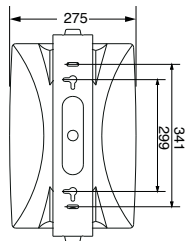
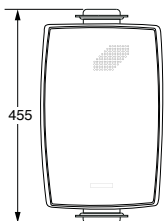
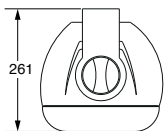

**NOTE :**

Not compatible with ROT45

**SPECIFICATIONS**

Power outputs :  
- 20 or 40 or 80W at 100V  
- 10 or 20 or 40W at 70V  
- 50W into 8 Ohms

• Power supply : 100 V/ 70 V or 8 Ohms

• Impedances :  
125 or 250 or 500 Ohms  
or 8 Ohms low impedance

• Components : 8" loudspeaker and 1" tweeter

• Sensitivity (1 M/1 W) : 92 dB

• Frequency response : 70 Hz - 18 kHz

• Material : ABS enclosure, steel grill

• Holding system : Adjustable holding bracket

• Connectors : 2-pin connector

• Dimensions : 302 x 172 x 165 mm

• Weight : 3.4 kg

# EHP 520

100V - 70V HiFi speaker

**Refined, compact, efficient**

EHP 520B    EHP 520W  
Black version    White version  
ref 9763        ref 9762

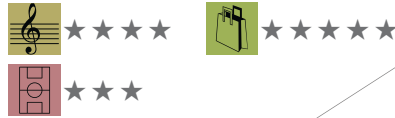

- + 40 W high-fidelity sound
- + Designed to be used indoor
- + Very discreet, black or white finishing
- + Built-in wall-mount bracket
- + Requires a low-impedance or a 100V line



## SPECIFICATIONS

- 2-way speaker
- RMS power output : 40 W into 8 Ohms
- Max power output : 150 W
- Power outputs : 40 W/ 20 W/ 10 W/ 5 W
- 8 Ohms/100 V/70 V
- Tweeter : 25 mm (1")
- Boomer : 125 mm (5")
- Frequency response : 80 Hz – 18 kHz
- Sensitivity: >89 dB
- External dimensions : 302 x 172 x 165 mm
- Net weight : 3.4 kg

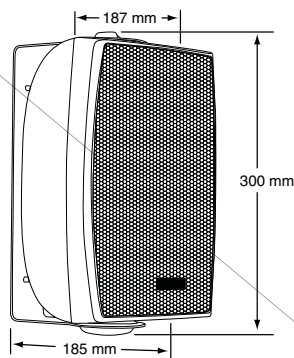

# EHP410

100V - 70V HiFi speaker

**High quality in a very discreet speaker**

EHP 410B  
Black version  
ref 9761

EHP 410W  
White version  
ref 9760

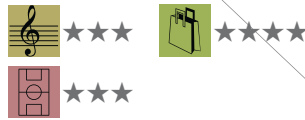

- + High-fidelity sound
- + Designed to be used indoor
- + Very compact, black or white finishing
- + Built-in wall-mount bracket
- + Requires a low-impedance or a 100V line

## SPECIFICATIONS

- |                                       |  |
|---------------------------------------|--|
| • 2-way speakers                      | • Boomer : 100 mm (4")                     |
| • RMS power output : 20 W into 8 Ohms | • Frequency response : 80 Hz – 18 kHz      |
| • Max power output : 70 W             | • Sensitivity: >89 dB                      |
| • Power outputs : 20 W/10 W/5 W/2.5 W | • External dimensions : 250 x 160 x 145 mm |
| • 8 Ohms/100 V/70 V                   | • Net weight : 1.45 kg                     |
| • Tweeter : 25 mm (1")                |  |

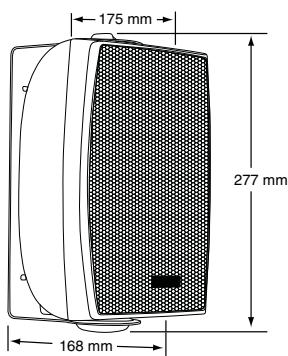

**SWIVEL-MOUNT BRACKETS FOR EHP520 AND EHP410 SPEAKERS.  
BLACK OR WHITE FINISHING AVAILABLE.**

**ROT 45b**

Black version - ref 9824

**ROT 45w**

White version - ref 9825



# Les ensembles triphoniques Systema

## Le son au naturel\*

\*The triphonic Systema sound systems: a natural sound





# OHO-SYSTEMA 1b

Triphonic amplified sound system

**This set features a 150 W compact subwoofer and 2x50 W satellites**

ref10156



HiFi



- + Spherical design
- + High-performance subwoofer
- + You can add 2 extra satellites

## SPECIFICATIONS

- 2 OHO-350 SATELLITES
- 1 MIO-SUB8150b SUBWOOFER

## OHO-350

Compact satellite

**Compact satellite with a magnetised base**

OHO350B  
Black version  
ref 10125

OHO350W  
White version  
ref 10124



- + Spherical design
- + 2-way coaxial loudspeaker

## SPECIFICATIONS

- Power output : 50 W RMS
- Frequency response : 100 Hz - 25 KHz
- Sensitivity (1 W@1m) : 89 dB
- Nominal impedance : 8 Ohms
- Boomer : 3"
- Tweeter : 1" compression
- Connector : Mount-integrated terminal
- Dimensions : 115 mm diam
- Weight : 0.7 kg

## MIO-SUB8150b

150W 8" self-powered subwoofer with 2x40W/4 ohms outputs

**Self-powered subwoofer with 2 satellite outputs**

ref 10153



- + High-performance self-powered subwoofer
- + Controls up to 4 satellites simultaneously
- + Integral steel mesh grille
- + XLR/Jack and RCA inputs
- + An independent LF volume controller

## SPECIFICATIONS

- Power output : 150 W
- Frequency response : 52 - 200 Hz
- Max SPL (@1m) : 120 dB
- Boomer : 8"
- Dimensions : 360 x 250 x 250 mm
- Weight : 10.3 kg
- AMPLIFIERS :**
- LF : 1 x 150 W
- HF : 2 x 40 W RMS / 4 Ohms

- Sub phase controller 0/180
- Sub and Master adjustable levels
- Connectors : 2 x Combo XLR/Jack et 2x RCA inputs
- SATELLITES TERMINAL**
- Indicators : Power/Signal/Clip
- Protections :
- Short-circuits/Thermal and limiter
- Convection cooled (totally silent)

# MIO-SYSTEMA 2b

Triphonic self-powered system  
**Power and natural sound**  
ref 10152

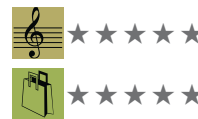

- + 230W RMS self-powered system
- + Designed to be used indoor
- + Compact satellites with an orientable mounting bracket
- + High-efficiency self-powered subwoofer
- + Controls up to 4 satellites simultaneously



## SPECIFICATIONS

- 2 MIO-SAT440b SATELLITES
- 1 MIO-SUB8150b SUBWOOFER

## MIO-SAT 440b

8 Ohms – 40 W HiFi speaker  
**Wall-mount speakers**  
ref 10154

- + 8 Ohms, 40 Watts speaker
- + Designed to be used indoor
- + Wooden enclosure - 2-way
- + Compact satellites with an orientable mounting bracket



## MIO-SUB8150b

150W 8" self-powered subwoofer with 2x40W/4 ohms outputs  
**Self-powered subwoofer with satellites outputs**  
ref 10153

- + High-efficiency self-powered subwoofer
- + Controls up to 4 satellites simultaneously
- + Steel mesh protective grille
- + XLR/Jack and RCA inputs
- + An independent LF volume controller



## SPECIFICATIONS

- Power output : 40 W RMS
- Frequency response : 120 Hz - 16 KHz
- Max SPL (@1m) : 116 dB
- Nominal impedance : 8 Ohms
- Boomer : 4"
- Tweeter : 1" compression
- Connector : Rear terminal
- Dimensions : 155x170x220 mm
- Weight : 2.6 kg

## SPECIFICATIONS

- Power output : 150 W
- Frequency response : 52 - 200 Hz
- Max SPL (@1m) : 120 dB
- Boomer : 8"
- Dimensions : 360 x 250 x 250 mm
- Weight : 10.3 kg
- AMPLIFIERS :**
- LF : 1 x 150 W
- HF : 2 x 40 W RMS / 4 Ohms

- Sub phase controller 0/180
- Sub and Master adjustable levels
- Connectors : 2 x Combo XLR/Jack and 2x RCA inputs
- SATELLITES TERMINAL**
- Indicators : Power/Signal/Clip
- Protections : Short-circuits/Thermal and limiter
- Convection cooled (totally silent)

# MIO-SYSTEMA 1b

Amplified triphonic sound system  
**A very unobtrusive sound system**  
ref 10148



- + 150W RMS self-powered system
- + Designed to be used indoor
- + Compact satellites with an orientable mounting bracket
- + High-efficiency self-powered subwoofer
- + Controls up to 4 satellites simultaneously

## SPECIFICATIONS

- 2 MIO-SAT225b SATELLITES
- 1 MIO-SUB6100b SUBWOOFER

## MIO-SAT225b

8 Ohms, 25 Watts speaker  
**Wall-mount speaker**  
ref 10150



- + 8 Ohms, 25 Watts speaker
- + Designed to be used indoor
- + Compact satellites with an orientable mounting bracket
- + The terminal is integrated within the support

## SPECIFICATIONS

- Power output : 25 W RMS
- Frequency response : 200 Hz - 15 KHz
- Max SPL (@1m) : 110 dB
- Nominal impedance : 8 Ohms
- Boomer : 2X2.75 "
- Connector : Mount-integrated terminal
- Dimensions : 90x136x180mm
- Weight : 0.950 kg

## MIO-SUB6100b

150W 6.5" self-powered subwoofer with 2x25W/4 ohms outputs  
**Self-powered subwoofer with satellites outputs**  
ref 10149

- + High-efficiency self-powered subwoofer
- + Controls up to 4 satellites simultaneously
- + Steel mesh protective grille
- + XLR/Jack and RCA inputs
- + An independent LF volume controller



## SPECIFICATIONS

- Power : 100 W
  - Frequency response : 50 - 200 Hz
  - Max SPL (@1m) : 112 dB
  - Boomer : 6.5 "
  - Dimensions : 320 x 240 x 200 mm
  - Weight : 8.5 kg
- AMPLIFIERS :**
- LF : 1 x 100 W
  - HF : 2 x 25 W RMS / 4 Ohms

- Sub phase controller 0/180
- Sub and Master adjustable levels
- Connectors : 2 x Combo XLR/Jack et 2x RCA inputs

### SATELLITES TERMINAL

- Indicators : Power/Signal/Clip
- Protections : Short-circuits/Thermal and limiter
- Convection cooled (totally silent)

# CHF860

8 Ohms recessed HiFi speaker

**Recessed speaker with a high sound quality**

ref 9909



- + High-fidelity sound
- + 2-way speaker with a real sound box
- + Refined design
- + Easy to install



## A DISCREET HIFI

The CHF860 are recessed speakers providing an incredible sound output. They are discreet and provide the same sound quality as classic top-of-the-range products.

## OUR ADVICE

To optimise your CHF860 speakers, we recommend to combine it with the class D T1300 or T1154 for 4 CHF860 Audiophony® amplifier (see p. 259).

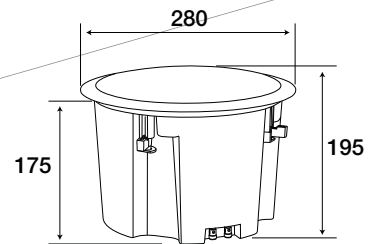

## SPECIFICATIONS

- 2-way speaker
- RMS power output : 60 W
- Max power output : 250 W
- Impedance : 8 Ohms
- Tweeter : 25 mm (1")
- Boomer : 165 mm (6.5")
- Frequency response: 40 Hz – 20 kHz
- Sensitivity: >90 dB
- External dimensions (diameter and depth) : 280 x 180 mm
- Drill hole diameter : 247 mm
- Net weight : 2.48 kg





# CHP660

8 Ohms/70 V/100 V Ceiling speaker

**Designed for the most demanding installations**

ref 9910



- + Warm, and precise sound output
- + 2-way speaker with a real sound box
- + Refined design
- + Easy to install

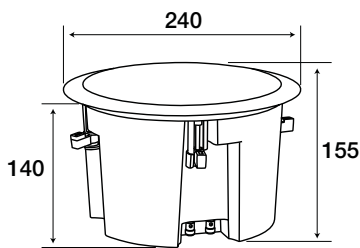

## 100 V AND LOW IMPEDANCE

The CHP-660 is a 2-way high-quality and very versatile ceiling speaker. The 6.5 coaxial loudspeaker produces a warm and generous sound output and can be operated with a 100 V line or at low impedance thanks to its incredible sound box.

## SPECIFICATIONS

- 2-way speaker
- RMS power output : 60 W into 8 Ohms
- Max power output : 200 W
- Power outputs : 1.25/2.5/5/10W under 70V or 100V
- 8 Ohms/70 V/100 V
- Tweeter : 25 mm (1")
- Boomer : 165 mm (6.5")
- Frequency response : 56 Hz – 20 kHz
- Sensitivity: >90 dB
- External dimensions (diameter and depth) : 240 x 140 mm
- Drill hole diameter : 208 mm
- Net weight : 1.75 kg

The volume controller allow you to adjust the volume to your needs.



# CHP620

100 V ceiling speaker

**High-quality voice and music**

ref 9757



- + 2-way speaker
- + Crystal-clear output
- + Simple and elegant design
- + Easy installation

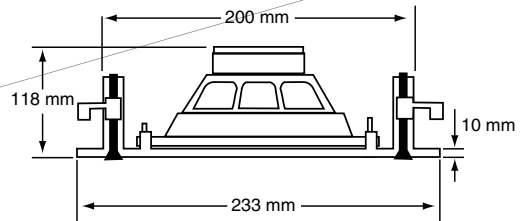

## SPECIFICATIONS

- 2-way speaker
- RMS power output : 20 W
- Max power output : 30 W
- Power outputs : 20 W or 10 W
- 100 V
- Tweeter : 25 mm (1.5 ")
- Boomer : 165 mm (6.5 ")
- Frequency response : 85 Hz - 18 kHz
- Sensitivity : >98 dB
- External dimensions (diameter and depth) : 233 x 118 mm
- Drill hole diameter : 200 mm
- Net weight : 1.7 kg

The CHP620 and CHP610 ceiling speakers feature a 2-way coaxial speaker producing a very pure sound even at low volume. The tweeter is incredibly efficient at transmitting a clear vocal reproduction.

# CHP610

100 V ceiling speaker

**A high-quality sound in all circumstances**

ref 9756



- + 2-way speaker
- + Deep, warm output
- + Simple and elegant design
- + Easy installation

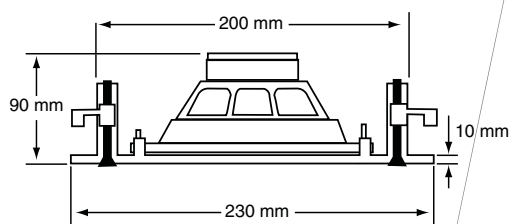

## SPECIFICATIONS

- 2-way speaker
- RMS power output : 10 W
- Max power output : 18 W
- Power output : 10 W, 5 W or 2.5 W
- 100 V
- Tweeter : 25 mm (1")
- Boomer : 165 mm (6.5")
- Frequency response : 56 Hz – 20 kHz
- Sensitivity : >93 dB
- External dimensions (diameter and depth) : 230 x 90 mm
- Drill hole diameter : 200 mm
- Net weight : 1.4 kg

# CHP606

100 V ceiling speaker

**An affordable way to be heard**

ref 9755



- + Clear and comprehensible vocal reproduction
- + Double cone loudspeaker
- + Easy installation



## EXAMPLE

The REG60 allows you to create different zones with their own volume. The COMBO60 allows you to amplify up to 20 CHP606 speakers.

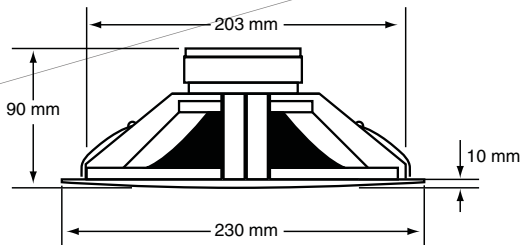
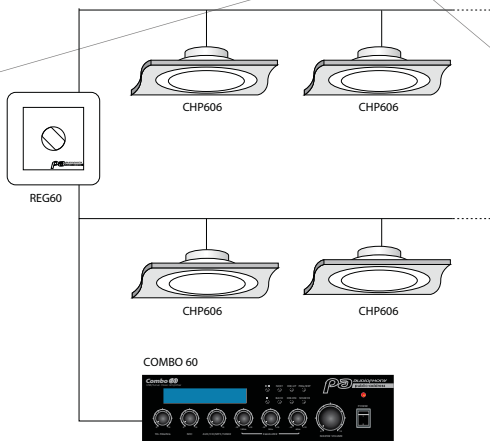

## SPECIFICATIONS

- Dual cone loudspeaker
- RMS power output : 6 W
- Max power output : 10 W
- Power outputs : 6 W or 3 W
- 100 V
- Loudspeaker : 165 mm (6.5 ")
- Frequency response : 110 Hz – 13 kHz
- Sensitivity >90 dB
- External dimensions (diameter and depth) : 230 x 90 mm
- Drill hole diameter : 200 mm
- Net weight : 0.9 kg



# CHP SUB

100V 8 Ohms Recessed subwoofer

**The perfect addition to increase the basses of your installations**

Ref 10533



HiFi

- + Closed metal housing
- + Built-in passive filter
- + Operates at 100V and 8 Ohms



4-pin Phoenix connectors

## SPECIFICATIONS

- Power: 20/40/60W at 100V and 60W at 8 Ohms
- Frequency response: 80Hz – 200Hz
- Boomer: 8"
- Connector: 4-pin Pheonix connectors
- Dimensions: Diameter 295 x height 215 mm
- Drilling diameter: 265 mm
- Net weight: 5kg

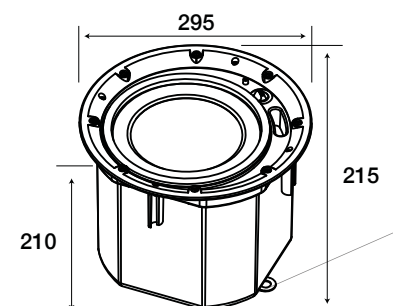

# SHP510

Pendant loudspeaker

**When sound rises above**

ref 9758

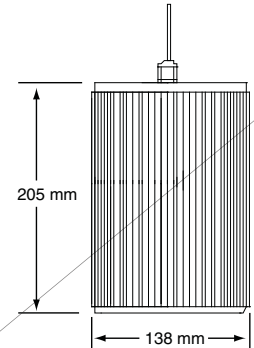

- + Perfect for high ceilings
- + Concealed safety-rope
- + Easy installation
- + IP55 (dust and water protected)

## SPECIFICATIONS

- Pendant loudspeaker
- RMS power output : 10 W
- Max power output : 18 W
- Power outputs : 2,5 W, 5 W ou 10 W
- 70/100 V
- Loudspeaker : 130 mm (5 ")
- Frequency response : 150 Hz – 15 kHz
- Sensitivity: >90 dB
- Material :White aluminium enclosure, white steel grille
- Fixation : Safety-rope inside the cable sheath
- Internal connector: waterproof cable gland
- IP level: IP55 (dust and water protected)
- Dimensions (L x D) : 138 x 205 mm
- Weight : 2.2 kg



## INDOOR / OUTDOOR

The SHP and PHP sound projectors are as good indoor as outdoor. They feature an integral aluminium housing and can be installed and operated even in poor weather.

Their large housing make them perfect for vast open spaces.

# PHP510

Surface mount loudspeaker

**When music takes to the streets**

ref 9759

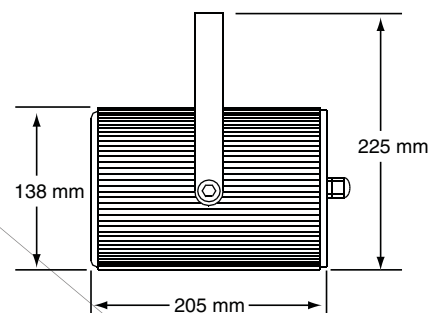

- + Perfect for outdoor installations
- + New removable and orientable holding bracket
- + Easy installation
- + IP55 (dust and water protected)

## SPECIFICATIONS

- Surface mount loudspeaker
- RMS power output : 10 W
- Max power output : 18 W
- Power outputs : 2,5 W, 5 W or 10 W
- 70/100 V
- Loudspeaker : 130 mm (5 ")
- Frequency response : 150 Hz – 14 kHz
- Sensitivity: >90 dB
- Material :White aluminium enclosure, white steel grille
- Fixation: Adjustable holding bracket
- Internal connector: waterproof cable gland
- IP level: IP55 (dust and water protected)
- Dimensions (L x D) : 138 x 205 mm
- Weight : 2.1 kg

# PHP650

50W Sound projector

**Weatherproof middle range broadcasting speaker**

ref 10211



- + Its high power and large housing can cover a vast area
- + Perfect vocal and music reproduction
- + Durable and weatherproof

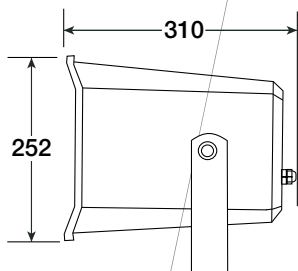
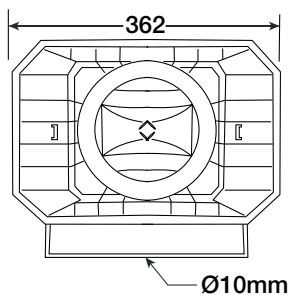

## SPECIFICATIONS

- Surface mount loudspeaker
- RMS power output : 50 W
- Power outputs : 2.6 W, 4.5 W, 9 W, 12.5 W, 25 W or 50 W
- 100 V
- Loudspeaker : 165 mm (6.5") et 1" compression
- Frequency response : 90 Hz – 20 kHz
- Sensitivity >99 +/-3 dB
- Material : ABS enclosure
- Fixation: Adjustable holding bracket
- Internal connector: waterproof cable gland
- IP level: IP55 (dust and water protected)
- Dimensions : 363 x 253 x 310 mm
- Weight : 3.9 kg

# CLS880

8 speakers column - 100V - 100V

**Subtle, wide-diffusion and weatherproof speaker**

Ref 10517

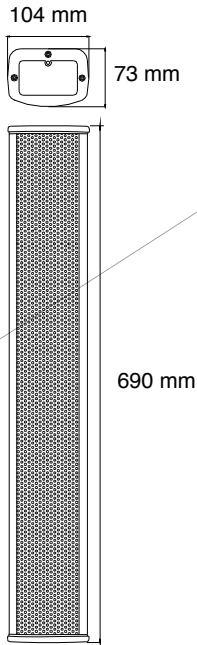

The multi-speaker system inside the columns allows a perfect horizontal sound diffusion while decreasing vertical sound propagation.

This was designed to avoid echoes from ceilings, in places with particularly complex acoustic configurations.

The column is the perfect too for any speech in large spaces.

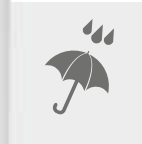

## SPECIFICATIONS

- Power: 40/80V
- Frequency response: 250Hz – 15KHz
- SPL (@1m): 97 dB
- Operates at 100V
- Speaker: 8 x 2,5"
- Connector: Cable gland securing the cable
- IP protection: IP44
- Dimensions: 104x 73 x 690 mm
- Weight : 3.34 kg

- + Perfect for voice reproduction in places of worship
- + Aluminium grille and housing
- + Weatherproof
- + Operates at 100V

# CLS660

6 speakers column - 100V

**Subtle, wide-diffusion and weatherproof speaker**

Ref 10516

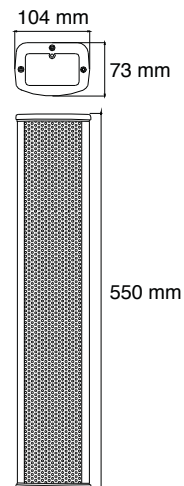

## SPECIFICATIONS

- Power 30/60W
- Frequency response: 250Hz – 15KHz
- SPL (@1m): 96 dB
- Operates at 100V
- Speaker: 6 x 2,5"
- Connector: Cable gland securing the cable
- IP protection: IP44
- Dimensions: 104x 73 x 550 mm
- Weight : 2.6 kg



# CLS440



4 speakers column - 100V

**Subtle, wide-diffusion and weatherproof speaker**

Ref 10515

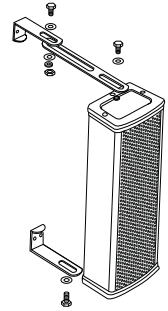

Columns are supplied with wall-mounting brackets

## SPECIFICATIONS

- Power 20/40W
- Frequency response: 250Hz – 15KHz
- SPL (@1m): 95 dB
- Fonctionne en 100V
- Speaker : 4 x 2,5"
- Connector: Cable gland securing the cable
- IP Protection: IP44
- Dimensions 104 x 73 x 402 mm
- Weight : 1.94 kg

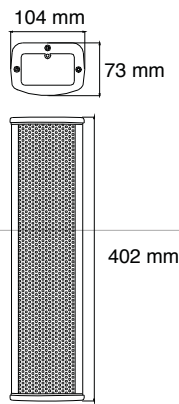

The aluminium speakers are designed to be weatherproof.

The cable is secured by a gland to secure its tightness.

# CLS220

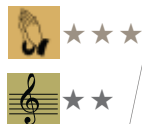

2 speakers column - 100V

**Subtle, wide-diffusion and weatherproof speaker**

Ref 10514

## SPECIFICATIONS

- Power 10/20W
- Frequency response: 250Hz – 15KHz
- SPL (@1m): 94 dB
- Operates at 100V
- Speaker : 2 x 2,5"
- Connector: Cable gland securing the cable
- IP Protection: IP44
- Dimensions: 104 x 73 x 262 mm
- Weight : 1.4 kg

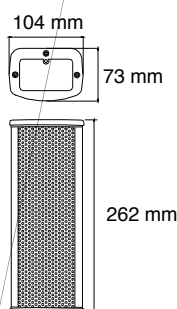

- + Perfect for voice reproduction in places of worship
- + Aluminium grille and housing
- + Weatherproof
- + Operates at 100V

# SOURCES AND AMPLIFIERS



## AUDIO FLUX MANAGEMENT

Buyoed by many years of experience, Audiophony is ready to offer you its new Audiophony PA series, based on a real respect of the audio quality and a very simple design, even with the most complex installations. Multi-zone management, non-stop broadcasting or integration in already existing systems has never been so easy. You do not need to adapt to our products, they will adapt to you.

# WALLAMP60



HiFi

Recessed HiFi amplifier

**Precision and sound quality within a compact device**

ref 9908



- + Compact recessed device
- + Class-D digital amplifier
- + Rear and front outputs
- + ON/OFF and volume control with the same button
- + 24V External power supply (supplied)

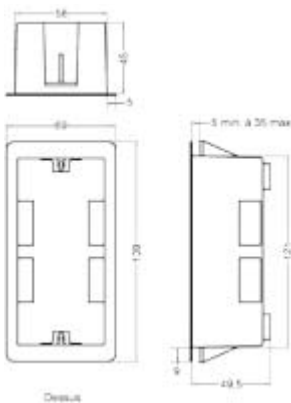

## SPECIFICATIONS

- Class-D amplifier
- 2 x 30 W stereo into 8 Ohms
- You can access inputs 1 and 2 from the front panel via jack 3,5 stereo
- You can access inputs 1 and 2 from the rear panel
- Auto-deactivation of the rear panel if you are using the front panel
- Input sensitivity : 280 mV
- Frequency response : 30 Hz – 20 kHz (-1.5 dB)
- Power supply : supplied with a 24 V 60 W, DC
- Housing box supplied
- Dimensions : 140 x 70 x 61 mm
- Net weight : 0.7 kg

## THE RECESSED AMPLIFIER

This wall-mount box can't make it easier to install the Wallamp60.



# WALLAMP-USB

2x30W In-wall Hi-Fi amplifier system with 2 Line inputs, USB reader and infrared remote control

**In-wall amplifier only**

ref 10660



**HiFi**

**NEW**

- + Recessed system
- + Class-D Amp
- + USB reader
- + Front and rear inputs
- + Infrared remote control
- + 3-mode equaliser



## SPECIFICATIONS

### AMPLIFIER:

- Class-D Amplifier
- 2 x 30 W stereo at 4 Ohms
- USB reader for keys with MP3/WMA/WAV files
- 3-mode equaliser: speech, hall, music
- A et B Line stereo inputs accessible at the front via stereo 3.5 jack
- A et B Line stereo inputs accessible at the rear via terminal
- Input sensitivity: 300 mV
- Frequency response: 20 Hz-20 kHz (+/-2dB)
- Power supply: 19V, DC 2,1A fournie
- Dimensions: 50 x 50 x 29 mm

Compatible with PILOTBOX (10637) – Square flush-mounted box

- Net weight: 0.11 Kg

### INFRARED REMOTE CONTROL:

- Control buttons:
  - ON/OFF and Mute
  - Volume +/-
  - Play/Pause
  - Previous/next track
  - A, B or USB source selection
  - Equalisation modes: hall, music, speech



# WALLAMP-USB PACK



HiFi

2x30W In-wall Hi-Fi amplifier system with 2 Line inputs, USB reader, set of speakers and infrared remote control

**A complete Hi-Fi solution within an ultra-compact format**

ref 10659

**NEW**



## SPECIFICATIONS

### AMPLIFIER:

- Class-D Amplifier
- 2 x 30 W stereo at 4 Ohms
- USB reader for keys with MP3/WMA/WAV files
- 3-mode equaliser: speech, hall, music
- A et B Line stereo inputs accessible at the front via stereo 3.5 jack
- A et B Line stereo inputs accessible at the rear via terminal
- Input sensitivity: 300 mV
- Frequency response: 20 Hz-20 kHz (+/-2dB)
- Power supply: 19V, DC 2,1A fournie
- Dimensions: 50 x 50 x 29 mm

Compatible with PILOTBOX – Square flush-mounted box

- Net weight: 0.11 Kg

### INFRARED REMOTE CONTROL:

- Control buttons:  
ON/OFF and Mute  
Volume +/-

- Play/Pause
- Previous/next track
- A, B or USB source selection
- Equalisation modes: hall, music, speech

### SPEAKER PAIR:

- 2-way speaker
- RMS output: 50 W
- Max output: 100 W
- Impedance: 8 Ohms
- Tweeter: 25 mm (0,75 inch)
- Boomer: 100 mm (4 inches)
- Frequency response: 80 Hz à 20 kHz (+/-3dB)
- Sensitivity >88 dB
- Materials: ABS housing and metal grille with adjustable fixation bracket and white finish
- Connectors: red and black spring terminal
- Dimensions: 245 x 160 x 160 mm
- Net weight: 1,6 kg per unit

# AMP120/240



Professional amplifier for 100v installations

**High sound quality, easy to use and install**

AMP120 ref 9903    AMP240 ref 9904

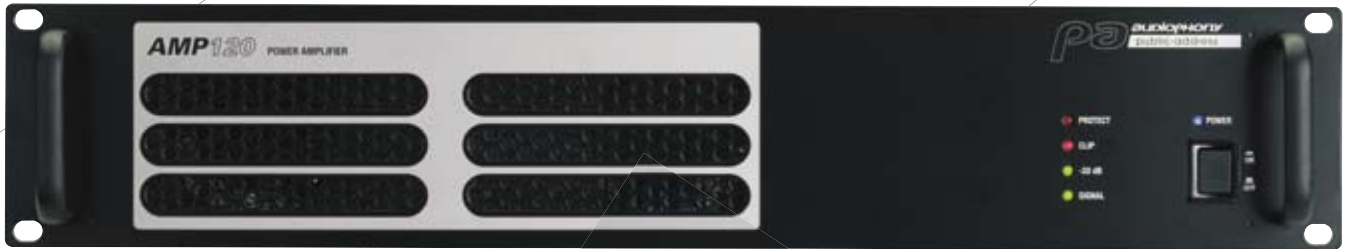

- + 120 W – 240 W according to the model
- + Operates under 8 Ohms / 70 V / 100 V
- + 24 V safety
- + Adjustable input level
- + Mountable in 19" wide racks
- + High-pass filter



## AMP120

- RMS power output : 120 W RMS
- Power outputs / Impedance :
  - 100 V (83 Ohms)
  - 70 V (42 Ohms)
  - 4 Ohms (21,9 V)
- Power consumption : 185 W
- Net weight : 11.6 kg

## AMP240

- RMS power output : 240 W RMS
- Power outputs / Impedance :
  - 100 V (42 Ohms)
  - 70 V (21 Ohms)
  - 4 Ohms (31 V)
- Power consumption : 361 W
- Net weight : 13.8 kg

AMP120 AND AMP240 REAR PANEL



**COMMON FEATURES**

- XLR balanced input
- XLR balanced output
- Power output terminal
- 24 V DC Input terminal
- Input sensitivity : 1.0 V (réglable)
- Input impedance : 10 kOhms (symétrique)
- Frequency response : 70 Hz - 18 kHz (+/-3 dB)
- T.H.D (1 kHz, 1/2 nominal power) : <1%
- Signal to noise ratio : 90 dB
- Ground Lift power switch
- Filtre Passe haut 400 Hz activable par switch
- Power supply :
  - 100 - 240 V, 50/60 Hz, AC
  - 24 V, DC (safe power supply)
- Protections : Short-circuits, Thermal, Overcharge
- Dimensions (L x H x D) : 482 x 88 x 330 mm
- Mountable in 19" wide racks
- Height : 2 units

**BUILT FOR PROFESSIONALS**

The AMP120 and AMP240 amplifiers were designed for professionals. They guarantee a safe yet very functional usage. They are really powerful and can direct a great number of speakers without losing any sound quality. Their adjustable input level helps them adapting to your system very easily and they deliver a crystal-clear sound, even at full power.



# AMP480



480W Amplifier at 100V

**Tons of power for biggest installations**

AMP480  
Ref 10512



- + 480W of power at 100V
- + Switched-mode power supply
- + Settings only accessible at the rear



## SPECIFICATIONS

- 1 mono input via Phoenix plug
- 1 Speaker output at 100V via Phoenix plug
- 1 line-level link output via Phoenix plug
- Channel volume settings
- Flat/HPF channel switch
- Output volume display via 4-LED viewmeter
- Screwdriver required to access technician-level settings

- Power supply: 230 V 50/60 Hz
- Frequency response: 50 Hz - 15 kHz
- T.H.D (1 kHz nominal power) : 0.1%
- Dimensions: 380 x 088 x 482 mm
- 19" mount-rackable
- Height: 2 units
- Weight : 6.6kg





# AMP4240/4120



4-way 240W and 120W amplifiers

**4 amplifiers in 1 to send sources to multiple zones**

AMP4240  
Ref 10506

AMP4120  
Ref 10511

- + 4x120W or 4x240W amplifiers at 100V
- + Compact and light design
- + Technician settings at the rear



## SHARED SPECIFICATIONS

- 4 Mono inputs via Phoenix plugs
- 4 Speaker outputs at 100V via Phoenix plug
- 4 Line-level link output via Phoenix plug
- Volume settings for each channel
- Flat/HPF Switch for each channel
- Output display for each channel via 4-LED VU meter
- Screwdriver required to access technician-level settings

- Power supply: 230 V 50/60 Hz
- Frequency response: 50 Hz - 15 kHz
- T.H.D (1 kHz nominal power): 0.1%
- Dimensions: 380 x 088 x 482 mm
- 19" mount-rackable
- Height: 2 units
- Weight: 7.2kg (AMP4120) 7.5kg (AMP4240)

# REG60

100 V power regulator

**A zone volume controller at your fingertips**

ref 9753



# REGBOX

Housing box for 1 REG60 wall-mounted controller

ref 9754



- + Volume control
- + Allow you to control independently each zone
- + Refined and easy to use
- + Easy installation



Set including a REG60 and a REGBOX

# COMBO240

Multi-zone mixer/amplifier

**A powerful and versatile device at the heart of your installation**

ref 9751



- + All-in-one multimedia system
- + 6-way mixer
- + 5 switchable zones
- + 7-band graphic equalizer
- + Tele-paging and chime functions
- + Mountable in 19" wide racks
- + Removable fixation brackets



## SPECIFICATIONS

### FRONT PANEL :

- 6-channel volume controllers and 1-channel general volume controller
- Zone selection key
- Chime activation
- Alarm activation
- 7-band equalizer
- LED view meter : -20 to + 3 dB

### REAR PANEL :

- 6-channel gain controllers
- Priority mode and Phantom power supply available for channel 1 and 2
- Adjustable chime and alarm volumes

### REAR INPUTS/OUTPUTS :

- 5-pin DIN input to control the chime
- XLR line/micro input on channels 2-5
- RCA line input on channel 6
- Remote paging via a 3-pin connector
- AMP IN and PRE-AMP OUT connections
- LINK IN et LINK OUT connections
- High-impedance loudspeakers outputs for channels 1-5
- Low-impedance loudspeakers outputs 8 to 4 Ohms

### TECHNICAL SPECIFICATIONS:

- Dimensions : 420 x 320 x 88 mm (19" Rack mounting brackets supplied)
- Weight : 10.8 kg
- RMS power output: 240 W RMS
- Output level / Impedance : - 100 V - 70 V - 8 and 4 Ohms



COMBO240 REAR PANEL



External preamp input

1 Micro/line input with gain control

5 Micro input with gain control

5x70 V/100 V outputs  
1x8/4 Ohms general output

Link IN/OUT to daisy chain

Remote paging controller

Priority mode (talkover) et Phantom power supply for channels 1 and 2

## MICDESK

Push-to-talk desk microphone  
ref 9748



Supplied with a COMBO240 5-pin cable to remotely activate the chime.

Jack cable without chime activation for the other amplifiers (COMBO60, COMBO130, PREZONE642).

### SPECIFICATIONS

- Push-to-talk button
- Frequency response : 40 Hz-16 kHz
- Sensitivity : -43 dB
- Impedance : 200 Ω
- Supplied with a 3-meter long cord
- Dimensions : 430 x 200 x 75 mm
- Weight : 1.05 kg

## MOD1

USB/SD reader and Tuner AM/FM receiver for COMBO240  
ref 9752



This module is a real multimedia player allowing you to play audio files from a SD card, USB key or hard disk and AM/FM tuner.

### SPECIFICATIONS

#### TUNER :

- Save your favourite stations
- Autoscan
- Manual scan
- FM coverage : 87.5 MHz - 108 MHz
- Frequency hopping : 50 kHz
- Antenna : 75 Ω asymétrique
- AM coverage : 522 kHz - 1620 kHz
- Frequency hopping : 9/10 kHz
- Antenna supplied

#### USB READER :

- Reading functions
- Searching functions
- Playlists programming

- MP3 file reading via a FAT32 formatted hard disk or USB key.
- Detects up to 2000 files and 200 folders.
- 32-character ID3 identification (Folder name / Title / Artist / Album)

#### EQUALIZER :

- Preset modes: Classical / Pop / Jazz / Rock with LOUD mode

#### TECHNICAL SPECIFICATIONS:

- Sound-to-noise ratio : <70 dB
- Frequency response : 20 Hz - 20 kHz
- THD : < 0.1%
- Max power consumption : 500 mA

# COMBO130



Mixer/Amplifier/Multimedia player

**Amplifier, mixer and tuner within the same housing**

ref 9750

- + All-in-one system
- + 5-channel mixer
- + Activate the chime via a pushbutton
- + Mountable in 19" wide racks
- + 70 V/100 V or low impedance amplified output
- + 1 front mic input



## SPECIFICATIONS

### FRONT PANEL CONTROLLERS :

- 3-channel mic volume control
- Aux1/MP3/Tuner volume control
- Aux2 volume control
- Bass/treble tone control
- MP3 reader and Tuner control
- Chime activation
- LED view meter

### REAR PANEL CONTROLLERS :

- Mute sensitivity control for priority signal

### REAR PANEL CONNECTORS :

- Mic 1 and 2 jack inputs
- RCA input for AUX1 and AUX2 channels
- RCA output to send a mixed signal to another amp
- AM/FM antenna connectors

- High-impedance loudspeaker outputs: 70 and 100 V
- Low-impedance loudspeaker outputs: 16 to 4  $\Omega$

### TUNER:

- Save your favourite stations
- Autoscan
- Manual scan
- FM coverage : 87.00 MHz - 108.00 MHz
- Frequency hopping: 10 kHz
- Antenna : Unbalanced 75  $\Omega$
- AM coverage : 522 kHz - 1611 kHz
- Frequency hopping : 9/10 kHz
- Antenna supplied

### USB READER:

- Reading functions
- Searching functions

- Playlist programmations
- MP3 file reading via a FAT32 formatted hard disk or USB key.

- Compatible with 500 Go devices
- 99 folders in 8 sub-directory levels
- Max sample rate: 320 kbps

### TECHNICAL SPECIFICATIONS :

- Power supply: 220 V 50-60 Hz
- Power consumption : 175 W
- Dimensions : 483(W) x 89(H) x 366(D) mm
- Net weight : 11.36 kg
- RMS power output : 130 W RMS
- Output level / Impedance: - 100 V - 70 V - 16-8 and 4 Ohms

364

REAR PANEL



preamp output for daisy chaining

70 V, 100 V or low-impedance power output

3 mic inputs: 1 at the front and 2 at the back

2 auxiliary inputs with adjustable volume



# COMBO60

Mixer/Amplifier/Multimedia player

**All-in-one, ultra compact and super efficient**

ref 9749



- + Compact all-in-one system
- + Built-in USB player and Tuner
- + 2 Line inputs and one Mic input
- + Music on hold and telepaging functions
- + Safety priority output
- + 3-band equalizer



## SPECIFICATIONS

### FRONT PANEL CONTROLLERS :

- 2-channel mic volume control
- Aux1/MP3/Tuner volume control
- Master volume control
- Bass/medium/treble tone control
- MP3 reader and Tuner control
- USB port for Mass storage reader

### REAR PANEL CONTROLLERS :

- Music on-hold volume settings
- Public announcements volume settings
- Aux / CD/MP3/Tuner front volume controller

### REAR PANEL CONNECTORS :

- AUX input via RCA connector
- CD input via RCA connector
- 3-pin telephone paging input connector

- Music on-hold 4-pin input connector
- Manual priority input terminal
- High-impedance loudspeaker outputs: 100 V
- Low-impedance loudspeaker outputs: 4, 8, 16  $\Omega$

### TUNER :

- Save your favourite stations
- Autoscans
- Manual scan
- FM coverage : 87.00 MHz - 108.00 MHz
- Frequency hopping: 10 kHz
- Antenna : Unbalanced 75  $\Omega$
- AM coverage : 522 kHz - 1611 kHz
- Frequency hopping: 9/10 kHz
- Antenna supplied

### USB READER:

- Reading functions
- Searching functions
- Playlist programmations
- MP3 file reading via a FAT32 formatted hard disk or USB key.
- Compatible with 500 Go devices
- 99 folders in 8 sub-directory levels
- Max sample rate: 320 kbps

### TECHNICAL SPECIFICATIONS :

- Power supply : 230 V - 50 Hz
- Dimensions L x W x H : 90 x 270 x 260 mm
- Weight : 5 kg
- RMS power output : 60 W RMS
- Output level / Impedance : - 100 V - 16-8 and 4 Ohms

REAR PANEL



2 line inputs/1mic input

Priority and speaker 100 V/4-16 Ohms outputs

Telephone paging and music on-hold functions

# ZONEAMP4120



Amplified mixing desk with 8 channels et 4 x 120W outputs

**A complete multi-zone mixing set with built-in amplifier**

Ref 10513



## 8 INPUTS

Each input can be sent to one or several zones of your choices.

Technicians settings can be accessed with a screwdriver.



## 4 OUTPUTS

The ZONEAMP4120 features a monitoring loudspeaker to check the signal sent by each output.

- + 4x120W Built-in amplifier at 100V with 8-channel mixer
- + Each input can be sent to the zone of your choice
- + Compatible with the WP1 wall-controller and MIC-DESK4



## SETUP EXAMPLE

Send your source to the zone of your choice  
Envoyez la source sur la zone de votre choix

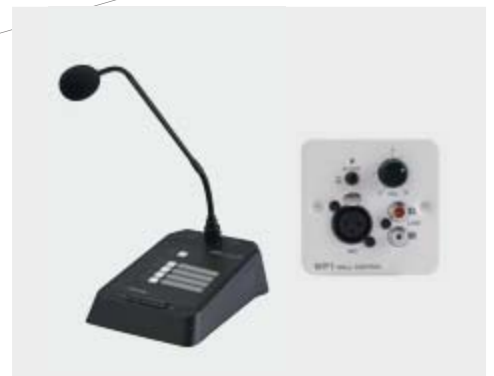
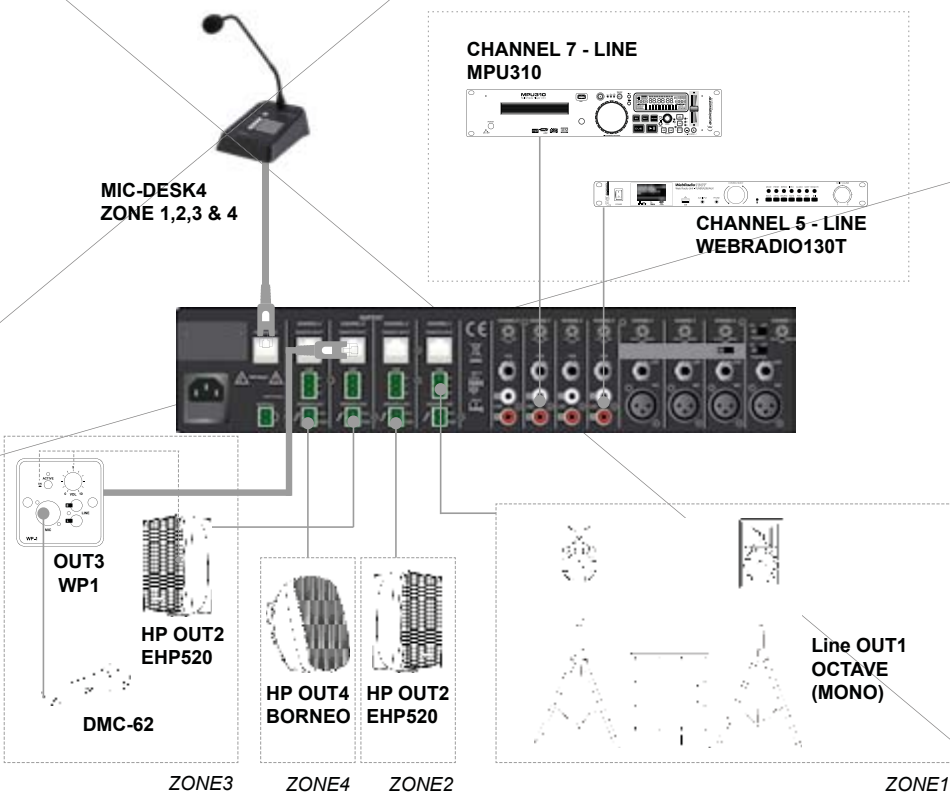

## WP1 AND MIC-DESK4 COMPATIBLE

The WP1 allows you to relocate an input into another room and control the volume of this zone.

The MIC-DESK4 is perfect for public announcements in selected zones.



RJ45 connector for MIC-DESK4

RJ45 connectors for WP-1



LINE Output to transmit the signal to an additional amplifier if required

100V 120W Speaker output

Stereo Line input for tuner, CD or TV player

Mono input for microphone

**SPECIFICATIONS**

- 4 symmetric Mic/Line inputs via XLR or Jack 6.35 (TRS)
- 4 stereo inputs via RCA or mono via Jack 6.35
- 4 symmetric link out outputs per zone via Phoenix plugs
- Balanced link output via Phoenix plug
- Microphone priority via input 1
- Phantom power supply for inputs 1 to 4
- Gain and tone settings (3 ways) for channels 1 to 4
- Gain settings via all inputs
- Tone settings (2 bands) per zone
- RJ45 Connector for WP-1 (remote input) wall controller and MIC-DESK (remote mic) for each zone
- Global Contact Mute
- Assign zones 1 to 4 to each input
- Peak and Signal display for each input
- Output display for each zone via 5-LED VU meter

- Headphones output with volume control (zones and PFL)
- Front monitoring speaker
- Screwdriver required to access technician-level settings
- Power supply: 230 V 50/60 Hz, and 24V DC
- Frequency response: 20Hz – 20KHz (+/-3 dB)
- T.H.D (1 kHz nominal power): < 0.1%
- Equalizer:
  - High : +/-15 dB @ 12kHz
  - Mid : +/-15 dB @ 2.5 kHz
  - Low +/- 15 dB @ 80 Hz
- Dimensions: 320 x 088 x 482 mm
- 19" Rackable
- Height: 2 units
- Weight : 9 kg

# MIC-DESK4

Microphone desk for ZONEAMP4120 or PREZONE444  
code 10509



- + Allows you to broadcast voice announcements
- + 4-zone selection
- + Chime commands

**SPECIFICATIONS**

- 1 mic input via XLR socket on the front panel
- 1 RJ45 rear output
- Talk button to activate the microphone (front panel)
- Chime button on the front panel
- Volume settings (Mic and Chime) via the rear panel
- Lock/unlock switch to block zones selection
- Output LED display
- Powered up via RJ45 cable from your ZONEAMP4120 or PREZONE444
- Frequency response: 45 Hz - 15 kHz
- T.H.D (1 kHz nominal power): < 0,1%
- Dimensions: 140 x 60 x 205 mm
- Weight: 0.9kg

# PREZONE444



Mixing desk with 8 channels and 4 independent output zones

**Compact, multi-source and easy to use device for 8 inputs and 4 outputs**

Ref 10507



## 8 INPUTS

Each input can be sent to one or several zones of your choices.

Technicians settings can be accessed with a screwdriver.



## 4 OUTPUTS

The PREZONE444 features a monitoring loudspeaker to check the signal sent by each output.

- + Each input can be sent to the zone of your choice
- + Compatible with the WP1 wall-controller and MIC-DESK4

## SETUP EXAMPLE

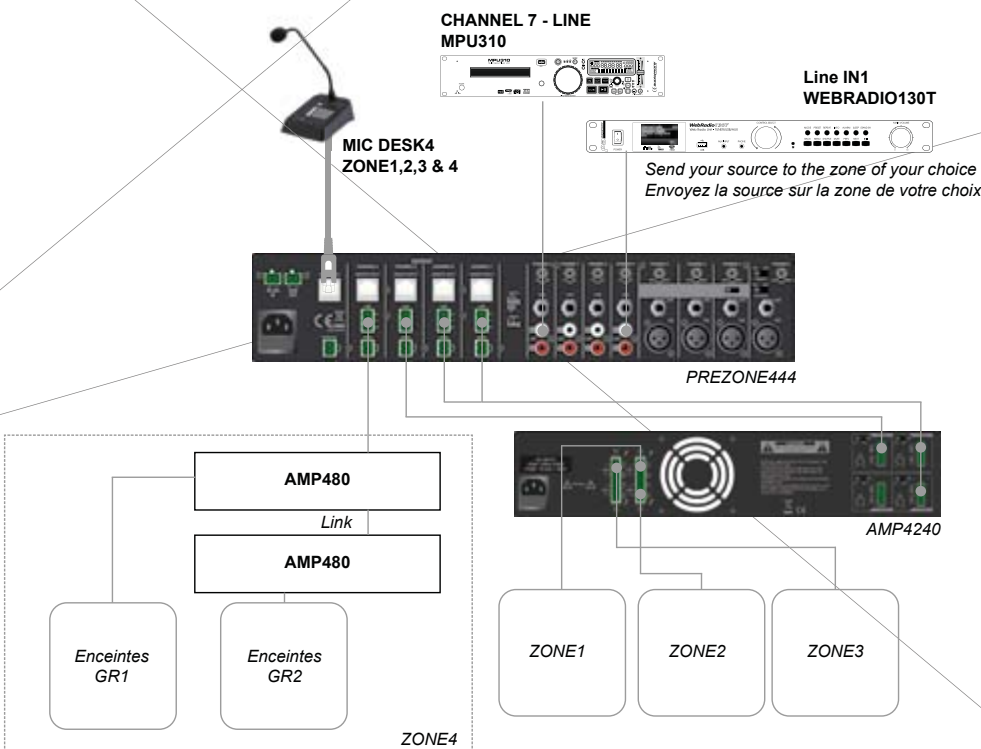

## WP1 AND MIC-DESK4 COMPATIBLE

The WP1 allows you to relocate an input into another room and control the volume of this zone.

The MIC-DESK4 is perfect for public announcements in selected zones.



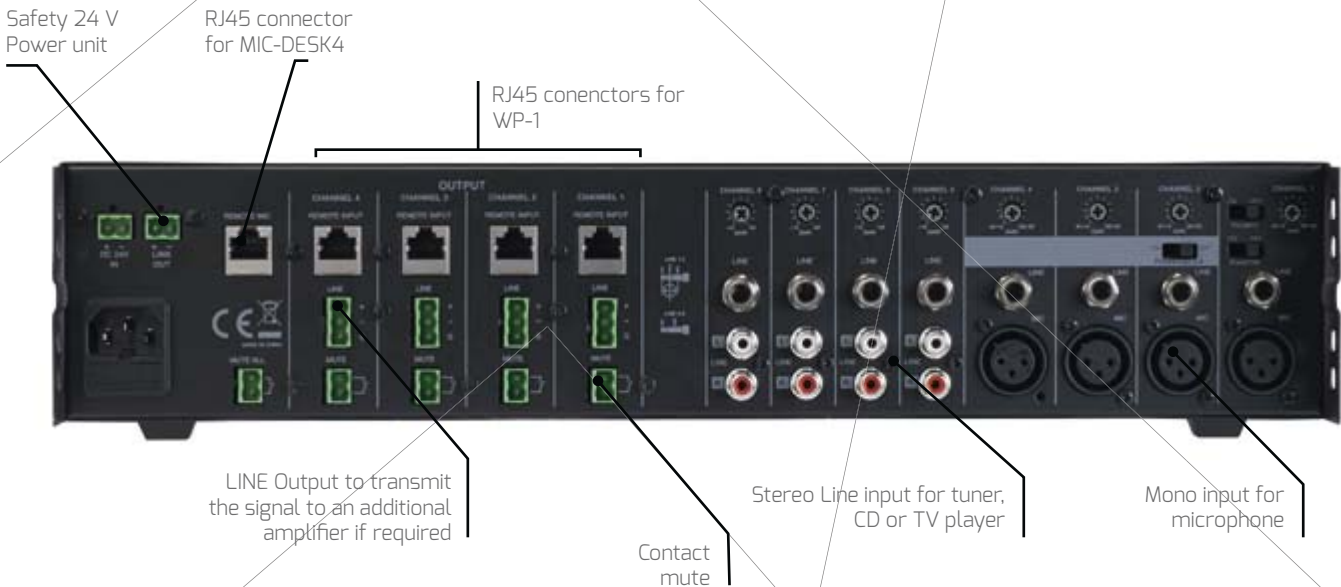

**SPECIFICATIONS**

- 4 symmetric Mic/Line inputs via XLR or Jack 6.35 (TRS)
- 4 stereo inputs via RCA or mono via Jack 6.35
- 4 symmetric link out outputs per zone via Phoenix plugs
- Balanced link output via Phoenix plug
- Microphone priority via input 1
- Phantom power supply for inputs 1 to 4
- Gain and tone settings (3 ways) for channels 1 to 4
- Gain settings via stereo inputs
- Tone settings (2 bands) per zone
- RJ45 Connector for WP-1 (remote input) wall controller and MIC-DESK (remote mic) for each zone
- Global Contact Mute
- Assign zones 1 to 4 to each input
- Peak and Signal display for each input
- Output display for each zone via 5-LED VU meter
- Headphones output with volume control (zones and PFL)
- Front monitoring speaker
- Screwdriver required to access technician-level settings
- Power supply: 230 V 50/60 Hz, and 24V DC
- Power consumption: 30 Watts
- Back-up power supply: 24V, DC with Link Out
- Frequency response: 20Hz – 20KHz (+/-3 dB)
- T.H.D (1 kHz nominal power): < 0.1%
- Equalizer:
  - High : +/-15 dB @ 12kHz
  - Mid : +/-15 dB @ 2.5 kHz
  - Low +/- 15 dB @ 80 Hz
- Dimensions: 320 x 088 x 482 mm
- 19" Rackable
- Height: 2 units
- Weight : 5 kg

# WP-1

Wall-mounted controller for ZONEAMP4120 or PREZONE444  
ref:10508



- + Allows you to either connect a microphone or external player to the selected channel
- + Direct access to volume controls on the controller
- + Controller powered up by the amplifier via RJ45



**RJ45 CONNECTOR**

The RJ45 connectors allow to use a 6th category cable to command the zone up to 200m away from the amplifiers.

**SPECIFICATIONS**

- 1 XLR Mic input (front)
- 1 RCA Line input (front)
- 1 RJ45 output (rear)
- Volume settings at the front
- ON/OFF Switch
- LED VU meter
- 15V, DC power supply via RJ45 cable from your ZONEAMP4120 or PREZONE444
- Operating range between WP-1 et the zone mixer: 200 metres with category 6 cable.
- Frequency response: 20 Hz - 20 kHz
- T.H.D (1 kHz nominal power): < 0.1%
- Dimensions: 80 x 80 x 50 mm
- Weight: 0.2kg

# PREZONE 642

10-channel and 2-zone preamplifier  
**Compact, multi-source preamplifier**  
ref 9902



- + 2 completely independent zones
- + 6 Mic inputs and 4 Line inputs
- + Output level meters for each zone
- + 24V safety power supply

### EACH MIC INPUT FEATURES :

- A gain control
- A 3-band equalizer
- This settings are made during the installation and can only be changed with a screwdriver

### EACH LINE INPUT FEATURES:

- A gain control  
(This settings are made during the installation and can only be changed with a screwdriver)

### EACH ZONE HAS ITS OWN :

- Volume control
- Equalizer
- SUB output settings
- Output level meter

### CONNECT A HEADSET TO BE ABLE TO:

- Use the PFL switches to monitor the pre-fader signal per zone
- Listen to the pre-fader signal of each channel independently.

1 SUB output per zone

1 insert per output

1 priority input

Input 1 and 2 with a Phantom power supply and Priority mode

REAR PANEL



Safety 24 V power unit

2 XLR balanced mono outputs

1 REC stereo output for RCA cable

4 Jack or RCA line inputs

6 micro/line inputs

370

## SPECIFICATIONS

- 6 Mono Mic/Line input via XLR/jack mono
- Phantom power supply and Talkover on channel 1 and 2
- 4 RCA or Jack stereo input
- Jack 6.35 Priority input
- Zone 1 and 2 mono balanced XLR output
- Jack 6.35 TRS zone insert
- 1 Jack balanced SUB output per zone
- RCA balanced stereo REC output
- 3-way tone and gain control via mic inputs
- Gain control via stereo inputs

- 2-way tone control per zone
- SUB volume control per zone
- Installer-dedicated settings accessible with a screwdriver
- Zone assignation, PFL on each channel strip
- LED Peak and Signal display
- A 8-LED view meter displays the output level for each zone
- Headset output with volume control (zones and PFL)
- Power supply : 230 V 50/60 Hz
- Power consumption : 16 Watts
- 24 V DC with Link Out emergency power supply

- Frequency response : 20 Hz - 20 kHz (+/- 3dB)
- T.H.D (1 kHz nominal power) : < 0,2%
- Equalizer :
  - High : +/- 12 dB @ 12,5 kHz
  - Mid : +/- 12 dB @ 2,5 kHz
  - Low +/- 12 dB @ 80 Hz
- Dimensions : 295 x 085 x 482 mm
- Mountable in 19" wide racks
- Height : 2 units
- Weight : 5 kg

# SUBMIX



Analog/digital mixer with an active filter

**This 6-channel mixer allows you to independently control your subwoofer**

ref 9573

- + Adjustable active filter for basses settings
- + 1 USB input/output to play files from a computer
- + 15 inputs and 2 outputs
- + Mountable in 19" wide racks

## THE SUBMIX IS A PERFECT TOOL TO OVERCOME FIELD CONSTRAINTS

Well thought-out layout : It features a rear terminal with multiple outputs and removable faders

High fidelity rendering : The components have been selected for their response time and reliability

Beautiful design : A high-quality finishing and materials with pleasant colours make the difference



Audio USB port to connect your MAC/PC

REAR PANEL

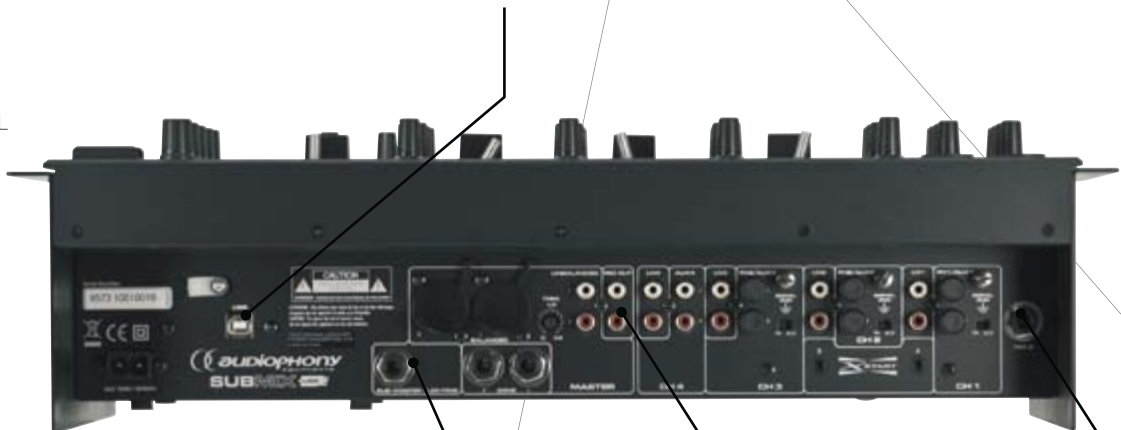

SUBWOOFER output

Zone/Master stereo balanced output

Line/phone/mic level inputs

6 simultaneous sources for a total of 15 inputs (phono, line, Aux or USB) and 3 mic inputs. The SUBWOOFER output works separately



The SUBMIX features a USB audio port PC and Mac compatible.

## TECHNICAL SPECIFICATIONS

- USB port on channel 3 allowing you to read and play audio files
- The console is automatically detected as a sound card by your computer (PC/Mac), without installing any driver
- SUB output with a frequency-adjustable active filter (40-200Hz) and 1 level
- 3 microphones front outputs, including 2 XLR/Jack combo outputs
- ON/OFF and talk-over functions via channel 1
- 3 RCA phone inputs
- 4 RCA line inputs
- 4 RCA auxiliary inputs
- 3-band equalizer for each channel
- 3-band equalizer for each micro channel
- Gain control for each channel

- Very low-leakage current assignable cross-fader
- Activate the Xstart function and use the cross-fader to play from the cued up point
- Unbalanced and balanced Master output
- Unbalanced Zone output
- Sensitivity output settings
- Master output Mono/Stereo modes
- LEDs view meter indicating the Master output and channels current state
- LED input indicator for each channel
- Power supply : 100 -240 V - 50 Hz
- Dimensions : 482 x 177 x 147 mm - 19" - 4 units
- Weight : 4.4 kg



# MXU230T

Tuner mixer/player  
**Tuner player/mixer**  
 ref 10182



- + CDB/USB/SD reader to play your mp3 files on all devices
- + AM/FM tuner
- + A mixing panel allows you to add up to 2 extra lines and 3 extra microphones



Supplied remote control



## SPECIFICATIONS

- AVM protected USB/Mp3 player
- USB reader with a USB mass storage output (at the front, max 16Go; FAT32 formatted)
- SD and SDHC reader with a front slot (16 Go max)
- Power output control
- AM/FM Tuner with autoscanner and a 10 stations memory capacity
- A button allows you to browse the repertoires and tracks
- Programmable or random playlists

- REMOTE CONTROL FUNCTIONS :**
- Source selection(CD, USB, SD or Tuner)
  - Play, pause, skip, search
  - Program, random and repeat functions
  - Track and folder selection
  - Find and save your favourite stations
  - Mute
  - CD eject

- ADDITIONAL CHARACTERISTICS:**
- Jack 3.5 Aux output
  - Jack 6.35 Micro 1 plug (at the front)
  - Jack 6.35 Mic 2 and 3 plugs (at the rear)
  - Unbalanced (-10 dB) 1 and 2 Outputs on RCA
  - Independent line and mic level settings
  - Power supply : 100/240V, AC - 50/60Hz or 12V, DC
  - Dimensions : 483 x 44 x 2755 mm
  - Net weight: 3.4 kg







# MPU130T

Multimedia and mp3 compatible Tuner/CD/USB/SD player

**Create your own sound atmosphere**

ref 9764



New autoplay function allowing to automatically play tracks from your CD/USB support or the radio, depending on the last function used

- + 4 Medias in a compact device
- + Access all the functions via the remote control
- + Programs and shuffle modes
- + Adjustable volume output
- + Mountable in 19" wide racks



Supplied remote control



## SPECIFICATIONS

- AVM protected USB/Mp3 player
- USB reader with a USB mass storage output (at the front, max 16Go, FAT32 formatted)
- SD and SDHC reader with a front slot (16 Go max)
- Output volume control
- AM/FM Tuner with autoscans and a 10 stations memory capacity
- A button allows you to browse the repertoires and tracks

- Infrared remote control supplied
- Random or programmable playlist
- Unbalanced (-10 dB) RCA output
- Mountable in 19" wide racks and ON/OFF power switch at the front
- Dimensions : 482 x 44 x 275 mm (1x19" unit)
- Power supply : 230 V, AC - 50 Hz or 12 V, DC
- Weight : 3.4 kg

### REMOTE CONTROL FUNCTIONS :

- Source selection (CD, USB, SD or Tuner)
- Play, pause, skip, search functions
- Program, random, and repeat modes
- Folder and file selection
- Select and save your favourite stations
- Mute
- Eject button

## TAME YOUR SOURCES

The MPU130T is a multi-media system. It is the ideal device to create a non-stop steady sound atmosphere, whatever the source. You can access hundreds of hours of music thanks to the USB port and SD slot. The functions are clear and easy-to-use as you can access them via the remote control or the front panel. Its one output guarantee you there will be no complicated connections to make.



# WEBRADIO130T

Online multimedia player

**Multi-sources system Wi-Fi or Ethernet connected to create the exact sound atmosphere you want**

ref 10183

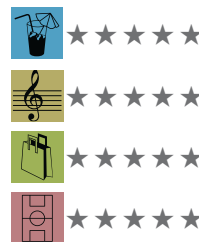

- + DAB or webradio modes to select high-quality international radio stations
- + The USB port allows you to play mp3 files via a hard disk
- + Share audio files from your network



## SPECIFICATIONS

374

- Radio : Ethernet or WiFi webradio, digital radio (DAB) and DAB+, FM with RDS
- Mp3 player : The USB port allows you to play mp3/AAC/WMA/FLAC files from a FAT32 USB key or external hard disk

- Shared files : Share the audio files and playlists on your network
- Programmable timer: Set up a schedule to automatically start/end playing playlists
- The infrared remote control gives you access to the main functions and volume settings
- Jack 3.5 Aux input

- RCA Line output and Headphones Jack 3.5mm output
- Large LCD screen drop-down menu available in 5 languages
- Power supply : 100/240V, AC - 50/60Hz ou DC12V
- Dimensions : 483 x 44 x 265 mm
- Net weight: 2.9 kg

# WEBRADIO 130T

Le moyen le plus simple d'accéder  
à toutes les radios du monde\*

\*Radio stations from all over the world come to your door



**pa** audiophony  
public-address





# **STAGE ACCESSORIES**

# MIC-100

Microphone stand  
**All-metal microphone stand with arm**  
 ref 8235

## TECHNICAL SPECIFICATIONS

- Materials :
  - Aluminium arm joint and base
  - Steel tubes
  - Rubber tube end caps
  - ABS clutch knob
- Finishing : Matte black epoxy paint
- Thread : 3/8"
- Arm length : 74 cm
- Height : from 1.05 - 1.60 m
- Legs diameter : 72 cm
- Net weight : 2.9 kg



# MIC-200T

Microphone stand  
**Telescopic microphone stand with a heavy duty base plate**  
 ref 8236

## TECHNICAL SPECIFICATIONS

- Materials :
  - Aluminium arm joint
  - Steel tubes and base
  - Rubber tube end caps
  - ABS clutch knobs and arm end
- Finishing : Matte black epoxy paint
- Thread : 3/8"
- Arm length : from 55 - 90 cm
- Height : from 92 cm - 1.52 m
- Base diameter : 25.5 cm
- Net weight : 5.3 kg

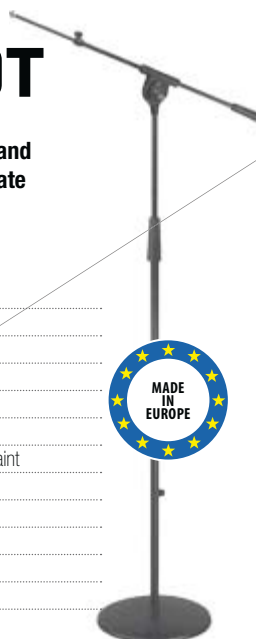

# MIC1-BAG

Case for a microphone stand  
**Case for 1 microphone stand**  
 ref10008



## TECHNICAL SPECIFICATIONS

- Open/close it with the drawstring
- Material : 600x600D High density polyester fabric
- Designed for the Audiophony MIC-100
- Side handle
- Max diameter : 10 cm
- Max height : 104 cm

# MIC5-BAG

Case for microphone stands  
**Case for 5 microphones stands**  
 ref 10009



## TECHNICAL SPECIFICATIONS

- Quick-release clips
- Material : 600x600D High density polyester fabric
- Designed for the Audiophony MIC-100
- 5 separated compartments
- Side strap
- Max diameter for each compartment : 10 cm
- Compartments height : 100 cm
- 28 cm lid

# MIS10

Microphone stand and its case  
**Microphone stand and its transport bag**  
 ref 10068

## TECHNICAL SPECIFICATIONS

### STAND

- Net weight : 1.8 kg
- Height : from 95 cm - 1.48 m
- Base spread diameter : 70 cm
- Thread : 3/8"
- Arm length : 77 cm
- Materials :
  - ABS leg housing and clutch knob
  - Steel tubes
  - Rubber tube end caps

### COVER

- ABS knobs and arm end
- Finishing : Matte black epoxy paint
- Open/close it with the drawstring
- Material : Polyester fabric
- Designed for the Audiophony MIC-100T and MIS10 mic stands
- Max diameter : 10 cm
- Max height : 110 cm



# TMIC-20

Table top microphone stand  
**Table top mic stand with a heavy table base H 30 cm**  
 ref 8232



# TMIC-10

Table top microphone stand  
**Table top mic stand - H 18 cm**  
 ref 8231

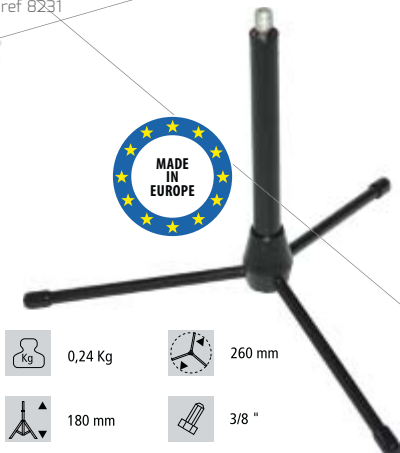

# TMIC-100

Swivel arm for microphone  
**Swivel arm for microphone + XLR cable + table fixation sys.**  
 ref 10458



|        |             |
|--------|-------------|
| 3,3 Kg | 740 mm      |
| 300 mm | 3/8"        |
| 220 mm | STEEL & ABS |

|         |        |
|---------|--------|
| 0,24 Kg | 260 mm |
| 180 mm  | 3/8"   |
| 260 mm  | STEEL  |

## KB-ROLL

Multi-functions DJ console stand  
**DJ console stand with built-in trolley**  
ref. 8224



Double  
function  
Stand  
+ Trolley



## KB4

Reinforced DJ console stand  
**Reinforced DJ console stand for Magnésium series**  
ref. 9663



## KB-UNO

Standard DJ console stand  
**Standard DJ console stand - H 60 à 93 cm**  
ref. 8226



## KB-BAG

Bag for DJ console stand  
**Bag for 1 DJ control stand**  
ref. 10007



Designed for the KB-ROLL, KB-UNO and KB4

## DJ4

Advanced DJ console stand  
**Magnésium series DJ console stand**  
Ref. 9665



### TECHNICAL SPECIFICATIONS

- Made in Europe
- Zip fastener
- Material : 600x600D High density polyester fabric
- Designed for the Audiophony KB-ROLL, KB-UNO and KB4 stands
- Side handle
- Max width : 50 cm
- Max height : 100 cm
- Max folded stand dimension : 5 cm thick

### TECHNICAL SPECIFICATIONS

- Net weight : 15 kg
- Height : from 68 - 92 cm
- Main desk dimensions : 45 x 100 cm
- Upper desk dimension : 30 x 60 cm
- Materials :
  - Steel tubes and desks
  - ABS end caps and clutch knobs
- Finishing : Anthracite epoxy paint

## KB-EXT70

DJ console stand extensions  
**70° Extension for DJ console stands**  
**H 24 cm - In pairs**  
ref. 8227



## KB-EXT90

DJ console stand extensions  
**90° Extension for DJ console stands**  
**H 24 cm - In pairs**  
ref. 8228





## MEDIASTAGE1

Smartphone holder

**Aluminium holder for smartphones and tablets**

ref 10495

- For 3,5 to 5,5 inches smartphones
- Material : Aluminium
- Dimensions (L×H×P) : 38 × 381 × 25 mm
- Dimensions when folded (L×H×P) : 38 × 168 × 25 mm
- Length of the arm (unfolded) : 238 mm
- Depth of the support : 17,5 mm
- Height of the support : from 57 à 89 mm
- Weight : 130 grams

## MEDIASTAGE2

Smartphone and tablet holder

**Aluminium holder with clamp for smartphones and tablets**

ref 10496

- For 4 to 11 inches smartphones
- Material : Aluminium
- Maximum load : 1 kg
- Weight : 500 grams



## MEDIASTAGE3

Smartphone and tablet holder

**Aluminium holder with suction cup for smartphones and tablets**

ref 10494

- For 4 to 11 inches smartphones
- Material : Aluminium
- Maximum load : 1 kg
- Weight : 500 grams

## MEDIASTAGE4

Smartphone and tablet holder

**Aluminium holder with dual suction cup for smartphones and tablets**

ref 10493

- For 4 to 11 inches smartphones
- Material : Aluminium
- Maximum load : 1 kg
- Weight : 500 grams





## MEDIA STAGE5

Smartphone and tablet holder

**Aluminium holder with suction cup for smartphones and tablets**

ref 10654



## MEDIA STAGE6

Smartphone and tablet holder

**Aluminium holder for smartphones and tablets**

ref 10655

## MEDIA2

Shelf holder

**Shelf holder for microphone stand**

ref 10457



## MEDIA3

Laptop stand

**Laptop stand + Table fixation system**

ref 10456



## MEDIA4

Adjustable media stand

**Magnésium series Orientable multimedia stand**

ref 9664



Safe holding system

### TECHNICAL SPECIFICATIONS

- Net weight : 2.8 kg
- Height : from 17 - 30 cm
- Width (top part) : 29 - 39 cm
- Materials :
  - Steel
  - ABS clutch knobs and end caps
- Finishing : Anthracite epoxy paint



# CAB-100

Speaker stand

**Small speaker stand • H 1.4 m**

ref 8246

## TECHNICAL SPECIFICATIONS

- Net weight : 3.2 kg
- Height : from 0.92 - 1.38 m
- Folded height : 76 cm
- Base spread diameter : 72 cm
- Load capacity : 30 kg
- Pipe diameter : 35 mm
- Materials :
- Steel tubes and leg housing
- Rubber end caps
- ABS clutch knobs
- Finishing : Matte black epoxy paint



# CAB-200

Speaker stand

**Very resistant all metal speaker stand • H 2 m**

ref 8245

## TECHNICAL SPECIFICATIONS

- Net weight : 4.5 kg
- Height : from 1.41 - 2.10 m
- Folded height : 1.08 m
- Base spread diameter : 1,2 m
- Load capacity : 40 kg
- Upper tube diameter : 35 mm
- Single leg reinforcement
- Materials :
- Steel tubes and leg housing
- Rubber end caps
- ABS clutch knobs
- Finishing : Matte black epoxy paint



# CAB1-BAG

Transport bag for speaker stand

**Transport bag for CAB100 & 200 speaker stands**

ref 10010



## TECHNICAL SPECIFICATIONS

- Made in Europe
- Open/close it with the drawstring
- Material : 600x600D High density polyester fabric
- Designed for the CAB-100 and CAB-200 stands
- Adjustable strap
- Max diameter : 20 cm
- Max height : 110 cm

# CAB2-BAG

Transport bag for 2 speaker stands

**Transport bag for 2 CAB100 & 200 speaker stands**

ref 10011



## TECHNICAL SPECIFICATIONS

- Made in Europe
- Open/close it with the drawstring
- Material : 600x600D High density polyester fabric
- Designed for the Audiophony CAB-100 and CAB-200 stands
- Adjustable strap
- Individual compartments
- Max diameter : 16 cm
- Max height : 110 cm

# CABSET

2 speaker stands + 1 cover kit

**Kit including 2 speaker stands and their transport bag**

ref 10069



## TECHNICAL SPECIFICATIONS

Kit including :

- 2 speaker stands
- 1 bag for 2 speaker stands

### STANDS

- Net weight : 4.7 kg
- Height : de 1.23 à 2.02 m
- Folded height : 1.04 m
- Base spread diameter : 1.2 m
- Load capacity : 40 kg
- Upper tube diameter : 35 mm
- Single leg reinforcement
- Materials :
  - Steel tubes and leg housing
  - Rubber end caps
  - ABS clutch knobs
- Finishing : Matte black epoxy paint

### COVER

- Open/close it with the drawstring
- Material : 600x600D High density polyester fabric
- Designed for the Audiophony CAB-100 and CAB-200 stands
- Individual compartments
- Adjustable strap
- Max diameter : 20 cm
- Max height : 110 cm

# TUB/LINK

Telescopic tube

**83-123 telescopic tube with a safety pin**

ref 9105



# FORK

Beam for two speakers

**35mm beam for two speakers W 42 cm, up to 40 kg**

ref 7916



**WALL MOUNTING AND SPEAKER STANDS**

|    |         |   |      |
|----|---------|---|------|
| 1  | SUPWALL | Adjustable wall mount for speakers - up to 40 kg  | 9104 |
| 2  | BS/5-1  | Adjustable wall mount for speakers - up to 40 kg  | 7907 |
| 3  | BS/6-1  | Adjustable wall mount for speakers - up to 20 kg  | 7906 |
| 4  | BYR     | Adjustable wall mount for speakers - up to 15 kg  | 1075 |
| 5  | SUPPLAT | Plastic base plate for a 36 mm stand 180 x 120 mm | 7903 |
| 6  | EYE-10  | Eyebolt for M10 insert - up to 230 kg             | 8843 |
| 7  | EYE-8   | Eyebolt for M8 insert - up to 140 kg              | 8842 |
| 8  | HOOK-12 | 12mm shackle - up to 400 kg                       | 8844 |
| 9  | CPL-35  | Adapter with a M8 screw for 35 mm stands          | 8248 |
| 10 | C-35    | Steel speaker top mount - internal diameter 35 mm | 8247 |
| 10 | C-36    | Steel speaker top mount - internal diameter 36 mm | 1077 |

**FLEXIBLE LAMPS**

|    |           |  |      |
|----|-----------|--|------|
| 11 | FLEX/BNC  | 12 V - 5 W Flexible lamp with a BNC connector      | 8215 |
| 12 | LED/ACCU  | Battery-operated LED flexible lamp                 | 8220 |
| 13 | LED/BNC   | LED flexible lamp - BNC                            | 8218 |
| 14 | LED/LIGHT | LED flexible lamp with a 220V dimmable transformer | 8219 |
| 15 | LED/XLR   | LED flexible lamp - XLR                            | 8217 |

**FASTENING STRIPS**

|    |           |  |       |
|----|-----------|--|-------|
| 16 | VELCRO-30 | VELCRO fastener 25 x 300 mm            | 8876  |
| 17 | VELCRO-60 | VELCRO fastener 45 x 600 mm            | 8877  |
| 18 | COLL520   | Reusable cable tie 48x200mm-100 units  | 10442 |
| 18 | COLL825   | Reusable cable tie 76x250 mm-100 units | 10443 |

**BATTERIES**

|     |            |                            |  |       |
|-----|------------|----------------------------|--|-------|
| 19  | PILE-6LR61 | 1 x 9 V Alkaline battery   | 8146   |       |
| NEW | 19         | PILE-VI-6LR61              | 1 x 9 V Alkaline battery (blister 20x unit)  | 10743 |
| 20  | PILE-LR06  | 6 x 1,5 V Alkaline battery | 8148   |       |
| NEW | 20         | PILE-VI-LR6                | 1,5V LR6 Alkaline battery (blister 10x unit) | 10744 |
| 21  | PILE-LR03  | 6 x 1,5 V Alkaline battery | 8147   |       |
| NEW | 21         | PILE-VI-LR3                | 1,5V LR3 Alkaline battery (blister 10x unit) | 10745 |
| NEW | 22         | PILE-VCR2025               | CR2025 battery (blister 10x unit)            | 10746 |

**GAFFER TAPES**

|    |              |  |      |
|----|--------------|--|------|
| 23 | GAFFA-STD/NO | 50 m tape : 5 cm cotton + polyethylene - Black | 3955 |
| 23 | GAFFA-STD/WH | 50 m tape : 5 cm - White                       | 8872 |
| 23 | GAFFA-STD/GR | 50 m tape : 5 cm - Grey                        | 8873 |
| 23 | GAFFA-PRO/NO | 50 m tape : 5 cm cloth extruded cotton - Black | 3956 |
| 23 | GAFFA-PRO/WH | 50 m tape : 5 cm cloth - White                 | 8874 |
| 23 | GAFFA-PRO/GR | 50 m tape : 5 cm cloth - Grey                  | 8875 |

**MICROPHONE ACCESSORIES**

|    |      |   |      |
|----|------|---|------|
| 24 | WS-3 | Black foam microphone windscreen  | 3686 |
| 25 | AD38 | Mic clip adapter 3/8 into 5/8   | 9930 |
| 26 | A415 | Microphone spring clip for wired microphones RS1, RP1, DMC62, thread 5/8, thread 3/8 (optional for the AD38)  | 0180 |
| 27 | A602 | Microphone rubber clip for wired microphones RS1, RP1, DMC62 and UHF GO and WAVE series microphones, thread 5/8, thread 3/8 (optional for the AD38) | 1078 |
| 28 | PM38 | 3/8 Microphone rubber clip for wired microphones RS1, RP1, DMC62 and UHF GO and WAVE series microphones, Thread 3/8 (optional for the AD38)         | 9929 |





# **CORDS AND CABLES**

# LINE/MICRO/DMX AND USB

Cables



## MALE/FEMALE USB CABLE

|   |           |   |      |
|---|-----------|---|------|
| 1 | CU/AMAF-5 | Male USB2.0 A / Female USB2.0 A cable - 5 m | 9271 |
|---|-----------|---|------|

## HIGH SPEED USB CABLE PERFECT FOR MIDI INTERFACES

|   |           |  |      |
|---|-----------|--|------|
| 2 | CU/AMBM-1 | Male USB2.0 A / Male USB2.0 B cable- 1 m | 9272 |
|   | CU/AMBM-5 | Male USB2.0 A / Male USB2.0 B cable- 5 m | 9287 |

## DMX 512 CORDS WITH 3 -PIN XLR AND AWG24 SHIELDED CABLE

|   |          |   |       |
|---|----------|---|-------|
| 3 | CDMX-0,6 | Male DMX XLR / 3-pin female XLR cable - 0.6m  | 10699 |
|   | CDMX-1   | DMX XLR male / XLR female 3-pin cable - 1 m   | 9273  |
|   | CDMX-1.5 | DMX XLR male / XLR female 3-pin cable - 1.5 m | 9288  |
|   | CDMX-3   | DMX XLR male / XLR female 3-pin cable - 3 m   | 9289  |
|   | CDMX-5   | DMX XLR male / XLR female 3-pin cable - 5 m   | 9290  |
|   | CDMX-10  | DMX XLR male / XLR female 3-pin cable - 10 m  | 9291  |
|   | CDMX-20  | DMX XLR male / XLR female 3-pin cable - 20 m  | 9292  |

## HYBRID CABLES FOR LIGHTING

|   |              |  |       |
|---|--------------|--|-------|
| 4 | CPCDMXLINK-1 | Hybrid powerCON / XLR 3G1.5mm <sup>2</sup> cable - 1m  | 10686 |
|   | CPCDMXLINK-3 | Hybrid powerCON / XLR 3G1.5mm <sup>2</sup> cable - 3m  | 10687 |
|   | CPCDMXLINK-5 | Hybrid PpowerCON / XLR 3G1.5mm <sup>2</sup> cable - 5m | 10688 |

## MICROPHONE CABLES

|            |             |   |   |
|------------|-------------|---|---|
| 5          | CM/XFXM-0.6 | XLR female / XLR male microphone cable - 0.6 m        | 9298  |
|            | CM/XFXM-1.5 | XLR female / XLR male microphone cable - 1.5 m        | 7947  |
|            | CM/XFXM-3   | XLR female / XLR male microphone cable - 3 m          | 7948  |
|            | CM/XFXM-6   | XLR female / XLR male microphone cable - 6 m          | 7949  |
|            | CM/XFXM-10  | XLR female / XLR male microphone cable - 10 m         | 7950  |
|            | CM/XFXM-20  | XLR female / XLR male microphone cable - 20 m         | 7951  |
| 6          | CM/XFJM-1.5 | XLR female / Jack male mono microphone cable - 1.5 m  | 7952  |
|            | CM/XFJM-3   | XLR female / Jack male mono microphone cable - 3 m    | 7953  |
|            | CM/XFJM-6   | XLR female / Jack male mono microphone cable - 6 m    | 7954  |
|            | CM/XFJM-10  | XLR female / Jack male mono microphone cable - 10 m   | 7955  |
|            | CM/XFJM-20  | XLR female / Jack male mono microphone cable - 20 m   | 7956  |
|            | 7           | CM/XMJM-1.5   | XLR male / Jack 6.35 mono male microphone cable - 1.5 m |
| CM/XMJM-3  |             | XLR male / Jack 6.35 mono male microphone cable - 3 m | 9297  |
| CM/XMJM-6  |             | XLR male / Jack female mono microphone cable - 6 m    | 7957  |
| CM/XMJM-10 |             | XLR male / Jack female mono microphone cable - 10 m   | 7958  |

## MALE JACK-JACK MONO CABLES

|   |             |  |      |
|---|-------------|--|------|
| 8 | CL-05/1.5   | 6 mm Jack male / Jack male mono line cable 1.5 m | 7976 |
|   | CL-05/3     | 6 mm Jack male / Jack male mono line cable 3 m   | 7977 |
|   | CL-05/6     | 6 mm Jack male / Jack male mono line cable 6 m   | 7978 |
|   | CL-05/10    | 6 mm Jack male / Jack male mono line cable 10 m  | 7979 |
| 9 | CL/JMJM-1.5 | Jack male / Jack male mono line cable 1.5 m      | 7980 |
|   | CL/JMJM-3   | Jack male / Jack male mono line cable 3 m        | 7981 |
|   | CL/JMJM-6   | Jack male / Jack male mono line cable 6 m        | 7982 |
|   | CL/JMJM-10  | Jack male / Jack male mono line cable 10 m       | 7983 |
|   | CL/JMJM-20  | Jack male / Jack male mono line cable 20 m       | 7984 |

## MALE STEREO JACK - STEREO JACK MALE CABLES

|    |           |  |      |
|----|-----------|--|------|
| 10 | CL-07/1.5 | Male stereo jack/ Male stereo jack cable 1.50 m  | 7995 |
|    | CL-07/3   | Male stereo jack/ Male stereo jack cable 3 m     | 7996 |
|    | CL-07/6   | 6mm Male stereo jack/ Male stereo jack cable 6 m | 7997 |
|    | CL-07/10  | Male stereo jack/ Male stereo jack cable 10 m    | 7998 |

# JACK/RCA/XLR/DIN

Cables

| MALE STEREO MINI-JACK MALE STEREO JACK CABLES      |               |  |       |
|--|---------------|--|-------|
| 1  | CL-71/1,5     | Male stereo Jack 3.5 mm/ 6.35 male stereo line cable 1.50 m      | 7999  |
|  | CL-71/3       | Male stereo Jack 3.5 mm/ 6.35 male stereo line cable 3 m         | 8000  |
|  | CL-71/6       | Male stereo Jack 3.5 mm/ 6.35 male stereo line cable 6 m         | 8001  |
|  | CL-71/10      | Male stereo Jack 3.5 mm/ 6.35 male stereo line cable 10 m        | 8002  |
| MALE STEREO MINI-JACK MALE STEREO MINI-JACK CABLES |               |  |       |
| 2  | CL-72/1,5     | Male stereo Jack 3.5 mm/ 6.35 male stereo line cable 1.50 m      | 8003  |
|  | CL-72/3       | Male stereo Jack 3.5 mm/ 6.35 male stereo line cable 3 m         | 8004  |
|  | CL-72/6       | Male stereo Jack 3.5 mm/ 6.35 male stereo line cable 6 m         | 8005  |
|  | CL-72/10      | Male stereo Jack 3.5 mm/ 6.35 male stereo line cable 10 m        | 8006  |
| 2 MALE STEREO JACK 2 MALE RCA                      |               |  |       |
| 3  | CL-23/1,5     | 2 x 4 2xMale jack / 2xMale RCA line cable 1.5 m                  | 8007  |
|  | CL-23/3       | 2 x 4 2xMale jack / 2xMale RCA line cable 3 m                    | 8008  |
| 2 MALE XLR 2 MALE RCA CABLES                       |               |  |       |
| 4  | CL-26/1,5     | 2 x 4 2xMale XLR / 2xMale RCA line cable- 1.5 m                  | 8167  |
|  | CL-26/3       | 2 x 4 2xMale XLR / 2xMale RCA line cable- 3 m                    | 8168  |
| 2 MALE JACK 2 MALE JACK CABLES                     |               |  |       |
| 5  | FL-22/1,5     | 2 x 4 2x Male Jack / 2x Male Jack mono line cable 1.5 m          | 8012  |
|  | FL-22/3       | 2 x 4 2x Male Jack / 2x Male Jack mono line cable 3 m            | 8013  |
|  | FL-22/6       | 2 x 4 2x Male Jack / 2x Male Jack mono line cable 6 m            | 8014  |
| 1 XLR FEMALE 2 XLR MALE CABLES                     |               |  |       |
| 6  | CL-28/0.6     | 1 Female XLR / 2 x Male XLR cable - 0,6m                         | 10670 |
| 1 XLR MÂLE 2 XLR FEMELLE CABLES                    |               |  |       |
| 7  | CL-29/0.6     | 1 Male XLR cable / 2 x Female XLR - 0,6m                         | 10671 |
| 2 JACK 2 MALE MONO XLR CABLES                      |               |  |       |
| 8  | CL-40/1.5     | 2 x Mono Jack 6.35 / 2 x Male XLR cable - 1,5m                   | 10672 |
|  | CL-40/3       | 2 x Mono Jack 6.35 / 2 x Male XLR cable - 3m                     | 10673 |
| 2 MALE XLR 2 MALE STEREO JACK CABLES               |               |  |       |
| 9  | CL-41/1.5     | 2 x Male XLR / 2 x Male stereo Jack cable -1,5m                  | 10674 |
|  | CL-41/3       | 2 x Male XLR / 2 x Male stereo Jack cable - 3m                   | 10675 |
| 2 MALE XLR 2 XLR FEMELLE CABLES                    |               |  |       |
| 10   | CL-2XM2XF/0.6 | Cordon 2 x XLR Mâle / 2 x XLR femelle - 0,6m                     | 10680 |
|  | CL-2XM2XF/1.5 | Cordon 2 x XLR Mâle / 2 x XLR femelle - 1,5m                     | 10681 |
|  | CL-2XM2XF/6   | Cordon 2 x XLR Mâle / 2 x XLR femelle - 3m                       | 10682 |
| 2 FEMELLE XLR 2 MALE MONO JACK CABLES              |               |  |       |
| 11   | CL-42/1.5     | 2 x Female XLR / 2 x Male mono Jack cable -1,5m                  | 10676 |
|  | CL-42/3       | 2 x Female XLR / 2 x Male mono Jack - 3m                         | 10677 |
| 2 FEMELLE XLR 2 MALE STEREO JACK                   |               |  |       |
| 12   | CL-43/1.5     | 2 x Female XLR / 2 x Male stereo Jack -1,5m                      | 10678 |
|  | CL-43/3       | 2 x Female XLR / 2 x Male stereo Jack - 3m                       | 10679 |
| MALE STEREO MINI-JACK 2 MALE JACK CABLES           |               |  |       |
| 13   | CL-31/1,5     | 2 x 4 1 Male stereo 3.5 Jack/ 2x Male Jack 1.5 m                 | 8015  |
|  | CL-31/3       | 2 x 4 1 Male stereo 3.5 Jack/ 2x Male Jack 3 m                   | 8016  |
| MINI-JACK MALE STRÉRÉO 2 XLR MÂLE CABLES           |               |  |       |
| 14   | CL-32/1.5     | Stereo Jack 3.5 / 2 x Male XLR cable - 1,5m                      | 10668 |
|  | CL-32/3       | Stereo Jack 3.5 / 2 x Male XLR cable - 3m                        | 10669 |
| 1 MALE STEREO JACK 2 MALE RCA CABLES               |               |  |       |
| 15   | CL-35/1,5     | 2 x 4 1 Male stereo Jack / 2xMale RCA line cable 1.5 m           | 8009  |
|  | CL-35/3       | 2 x 4 1 Male stereo Jack / 2xMale RCA line cable 3 m             | 8010  |
|  | CL-35/6       | 2 x 4 1 Male stereo Jack / 2xMale RCA line cable 6 m             | 8011  |
| INSERT JACK LINE CABLES                            |               |  |       |
| 16   | CL-36/1,5     | Male stereo 6.35 Jack / 2 x 6.35 mono line cable 1.5 m           | 9294  |
|  | CL-36/3       | Male stereo 6.35 Jack / 2 x 6.35 mono line cable 3 m             | 9295  |
| 2 FEMALE XLR 2 MALE RCA CABLES                     |               |  |       |
| 17   | CL-25/1,5     | 2 x 4 1 Male stereo Jack 3.5 / 2xMale RCA 1.5 m                  | 8165  |
|  | CL-25/3       | 2 x 4 1 Male stereo Jack 3.5 / 2xMale RCA 3 m                    | 8166  |
| MALE STEREO MINI-JACK 2 MALE RCA CABLES            |               |  |       |
| 18   | CL-30/1,5     | Cordon ligne 2 x 4mm - 1 Jack 3,5 stéréo mâle / 2xRCA mâle 1,5 m | 8017  |
|  | CL-30/3       | Cordon ligne 2 x 4mm - 1 Jack 3,5 stéréo mâle / 2xRCA mâle 3 m   | 8018  |
| DIN CABLES   |               |  |       |
| 19   | CL-51/ 0,6    | Male DIN 5B - Male DIN 5B midi cable - 0.6 m                     | 9299  |
|  | CL-51/1       | Male DIN 5B - Male DIN 5B midi cable - 1 m                       | 9300  |
|  | CL-51/3       | Male DIN 5B - Male DIN 5B midi cable - 3 m                       | 8019  |
|  | CL-51/6       | Male DIN 5B - Male DIN 5B midi cable - 6 m                       | 8020  |





# RCA LINE AND SPEAKERS

Cables



## RCA LINE CABLES

|   |           |  |      |
|---|-----------|--|------|
| 1 | RCA1/C    | 2 Male RCA / 2 Male RCA cable - 1.20 m             | 0049 |
| 2 | CL-24/1.5 | 2 x 4 2xMale RCA / 2xMale RCA Pro line cable 1.5 m | 7964 |
|   | CL-24/6   | 2 x 4 2xMale RCA / 2xMale RCA Pro line cable 6 m   | 7966 |
| 3 | CL-27/1.5 | 2xFemale RCA / 2xMale RCA line cable 1.50 m        | 7967 |
|   | CL-27/3   | 2xFemale RCA / 2xMale RCA line cable 3 m           | 7968 |
|   | CL-27/6   | 2xFemale RCA / 2xMale RCA line cable 6 m           | 7969 |
|   | RCA11/C   | 2xMale RCA / 2xMale RCA HQ line cable - 1.20 m     | 7970 |
| 4 | RCA13/C   | 2xMale RCA / 2xMale RCA HQ line cable - 3 m        | 7971 |
|   | RCA15/C   | 2xMale RCA / 2xMale RCA HQ line cable - 5 m        | 7972 |
|   | RCA/PH    | 2xMale RCA / 2 Male RCA + ground wire cable - 3 m  | 7973 |
| 6 | RCA25/C   | 4xMale RCA / 4xMale RCA cable - 1.50 m             | 7974 |

## HYBRID AUDIO CABLES - PERFECT FOR AMPLIFIED SPEAKERS

|   |         |   |      |
|---|---------|---|------|
| 7 | CDU0-10 | VDE/IEC - Male XLR/Female XLR hybrid audio cable - 10 m | 9274 |
|   | CDU0-20 | VDE/IEC - Male XLR/Female XLR hybrid audio cable - 20 m | 9293 |

## MALE JACK / MALE JACK SPEAKER CABLES

|   |             |   |      |
|---|-------------|---|------|
| 8 | CH/JMJM-1.5 | 2 x 1.5 Male Jack / Male Jack speaker cable 1.5 m | 8023 |
|   | CH/JMJM-3   | 2 x 1.5 Male Jack / Male Jack speaker cable 3 m   | 8024 |
|   | CH/JMJM-10  | 2 x 1.5 Male Jack / Male Jack speaker cable 10 m  | 8025 |
|   | CH/JMJM-15  | 2 x 1.5 Male Jack / Male Jack speaker cable 15 m  | 8026 |

## SPEAKER / JACK CABLES

|   |            |   |      |
|---|------------|---|------|
| 9 | CH/SMJM-3  | 2 x 1.5 Male Speaker / Male Jack cable 3 m  | 8034 |
|   | CH/SMJM-6  | 2 x 1.5 Male Speaker / Male Jack cable 6 m  | 8035 |
|   | CH/SMJM-10 | 2 x 1.5 Male Speaker / Male Jack cable 10 m | 8036 |
|   | CH/SMJM-20 | 2 x 1.5 Male Speaker / Male Jack cable 20 m | 8037 |

## MALE SPEAKER / MALE SPEAKER CABLES

|    |          |   |      |
|----|----------|---|------|
| 10 | CS-21/3  | 2 x 1.5 Male Speaker /Male speaker cable 3 m  | 8038 |
|    | CS-21/6  | 2 x 1.5 Male Speaker /Male speaker cable 6 m  | 8039 |
|    | CS-21/10 | 2 x 1.5 Male Speaker /Male speaker cable 10 m | 8040 |
|    | CS-21/15 | 2 x 1.5 Male Speaker /Male speaker cable 15 m | 8041 |
|    | CS-21/20 | 2 x 1.5 Male Speaker /Male speaker cable 20 m | 8042 |

## NEUTRIK® SPEAKER CABLES

|    |            |  |       |
|----|------------|--|-------|
| 11 | CSP215/0.5 | NEUTRIK® 2 x 1.5 Speakon/Speakon speaker cable 0,5 m | 10695 |
|    | CSP215/1   | NEUTRIK® 2 x 1.5 Speakon/Speakon speaker cable 1 m   | 10696 |
| 12 | CSP215/3   | NEUTRIK® 2 x 1.5 Speakon/Speakon speaker cable 3 m   | 9840  |
|    | CSP215/6   | NEUTRIK® 2 x 1.5 Speakon/Speakon speaker cable 6 m   | 9841  |
|    | CSP215/10  | NEUTRIK® 2 x 1.5 Speakon/Speakon speaker cable 10 m  | 9842  |

\* High-quality speaker cables. 1.5mm<sup>2</sup> or 2 mm<sup>2</sup> low resistance extra-flexible cables. Authentic NEUTRIK® Speakon connectors



# XLR/JACK AND MORE

Connectors



## 3-PIN XLR CONNECTORS

|   |         |   |      |
|---|---------|---|------|
| 1 | FXF/CH  | Female XLR connector - Chromium plating | 2487 |
| 2 | FXF/NO  | Female XLR connector - Black finish     | 7932 |
| 3 | FXM/CH  | Male XLR connector - Chromium plating   | 2488 |
| 4 | FXM/NO  | Male XLR connector - Black finish       | 7933 |
| 5 | XFC-103 | Female XLR D-size metal chassis         | 6586 |
| 6 | XMC-103 | Male XLR D-size metal chassis           | 6585 |

## XLR CONNECTORS FOR DMX DEVICES

|   |         |                            |      |
|---|---------|----------------------------|------|
| 7 | XMK-105 | 5-pin male XLR connector   | 6587 |
| 8 | XFK-105 | 5-pin female XLR connector | 6588 |

## JACK CONNECTORS

|    |          |   |      |
|----|----------|---|------|
| 9  | FJM/CH   | Jack 6.35 mm mono connector - Chromium plating    | 2495 |
| 10 | FJS/CH   | Jack 6.35 mm mono connector - Chromium plating    | 2496 |
| 11 | J350/MO  | High quality Female Jack 6.35 mm mono connector   | 7936 |
| 12 | J350/STE | High quality Female Jack 6.35 mm stereo connector | 7937 |
| 13 | J700     | Female Jack 6.35 mm stereo locking chassis        | 7939 |

## RCA CONNECTORS

|    |           |  |      |
|----|-----------|--|------|
| 14 | RCA910/RO | Male RCA connector for pro cable - Red     | 7940 |
|    | RCA910/NO | Male RCA connector for pro cable - Black   | 7941 |
| 15 | RCA920/RO | Female RCA connector for pro cable - Red   | 7942 |
| 16 | RCA920/NO | Female RCA connector for pro cable - Black | 7943 |

## BANANA CONNECTORS

|    |            |                               |      |
|----|------------|-------------------------------|------|
| 17 | BANA100/NO | Male banana connector - Black | 1653 |
| 18 | BANA100/RO | Male banana connector - Red   | 1652 |
| 19 | BANA200/NO | Female banana chassis - Black | 1655 |
| 20 | BANA200/RO | Female banana chassis - Red   | 1654 |

## ADAPTTERS FOR AMPLIFIERS TERMINAL

|    |            |  |      |
|----|------------|--|------|
| 21 | BANA150/NO | Adaptater for banana plug - Black        | 6595 |
| 22 | BANA150/RO | Adaptater for banana plug - Red          | 6596 |
| 23 | BANA400/NO | 2xFemale banana chassis -1 Red / 1 Black | 7944 |

## SEETRONICS® CONNECTORS

|    |          |  |       |
|----|----------|--|-------|
|    | SC3FXX-W | Seetronic® Waterproof XLR 3P female connector - IP65 | 10716 |
| 24 | SC3MXX-W | Seetronic® Waterproof XLR 3P male connector - IP65   | 10717 |
|    | SC5FXX-W | Seetronic® Waterproof XLR 5P female connector - IP65 | 10718 |
|    | SC5MXX-W | Seetronic® Waterproof XLR 5P male connector - IP65   | 10719 |
| 25 | SAC3FX   | Seetronic® Waterproof Power in connector - IP65      | 10720 |
|    | SAC3MX   | Seetronic® Waterproof Power out connector - IP65     | 10721 |

## DIN CABLES

|    |           |   |        |
|----|-----------|---|--------|
| 26 | MDIN8/1.5 | DIN8 / DIN8 1 m CD remote control cable | Z00322 |
|    | MDIN8/3   | DIN8 / DIN8 3 m CD remote control cable | Z00817 |

**NEUTRIK®**

Connectors



**NEUTRIK® XLR CONNECTORS**

|      |           |                                 |       |
|------|-----------|---------------------------------|-------|
| 1    | NE8MC     | RJ45 CAT5e Connector            | 10446 |
| 2    | NE8FDP    | RJ45 CAT5e Female socket        | 10447 |
| 3    | NC-3FFX   | 3-pin female XLR connector      | 8846  |
| 3bis | NC-3FX-HD | 3-pin female XLR connector IP67 | 10714 |
| 4    | NC-3MXX   | 3-pin male XLR connector        | 8848  |
| 4bis | NC-3MX-HD | 3-pin male XLR connector IP67   | 10715 |
| 5    | NC-5FFX   | 5-pin female XLR connector      | 8850  |
| 6    | NC-5MXX   | 5-pin male XLR connector        | 8851  |

**NEUTRIK® XLR CHASSIS CONNECTORS**

|    |          |                               |      |
|----|----------|-------------------------------|------|
| 7  | NC-3FDLX | 3-pin female XLR receptacle   | 8852 |
| 8  | NC-3MDLX | 3-pin male XLR receptacle     | 8853 |
| 9  | NC-5FDL1 | 5-pin female XLR D-size shell | 4840 |
| 10 | NC-5MDL1 | 5-pin male XLR D-size shell   | 4841 |

**NEUTRIK® MISCELLANEOUS**

|    |          |  |      |
|----|----------|--|------|
| 11 | NA-USB   | USBA-B D series receptacle               | 8854 |
| 12 | NYS373-0 | RCA connector with gold contacts - Black | 8855 |
| 13 | NYS373-2 | RCA connector with gold contacts - Red   | 8856 |

**NEUTRIK® JACK CONNECTORS**

|    |              |  |      |
|----|--------------|--|------|
| 14 | NTP3RC       | Jack 3.5 stereo elbow connector                  | 7946 |
| 15 | NP-2X        | Male Jack 6.35 mono connector                    | 8859 |
| 16 | NP-3X        | Male Jack 6.35 stereo connector                  | 8861 |
| 17 | NJ-3FC6      | Female Jack 6.35 stereo connector                | 4846 |
| 18 | NJ-3FP6C     | Female Jack 6.35 D-size shell                    | 4848 |
| 19 | NP2C-SILENT  | Jack mono connector with silentPLUG system       | 8857 |
| 20 | NP2RX-SILENT | Jack mono elbow connector with silentPLUG system | 8858 |

**NEUTRIK® ELBOW CONNECTORS**

|    |         |                                       |      |
|----|---------|---------------------------------------|------|
| 21 | NC-3FRX | 3-pin female XLR elbow connector      | 8863 |
| 22 | NC-3MRX | 3-pin male XLR elbow connector        | 8865 |
| 23 | NP-2RX  | Male Jack 6.35 mono elbow connector   | 4854 |
| 24 | NP-3RX  | Male Jack 6.35 stereo elbow connector | 4855 |

**NEUTRIK® SPEAKON CONNECTORS**

|    |         |                                   |      |
|----|---------|-----------------------------------|------|
| 25 | NL-2FC  | Speakon 2-pole connector          | 4856 |
| 26 | NL-4FX  | Speakon X series 4-pole connector | 4857 |
| 27 | NL-4MMX | Speakon X series 4-pole adapter   | 4859 |

**SPEAKON NEUTRIK® CHASSIS CONNECTORS**

|    |         |   |      |
|----|---------|---|------|
| 28 | NL-2MP  | Speakon D series 2-pole chassis connector | 4861 |
| 29 | NL-4MP  | Speakon D series 4-pole chassis connector | 4862 |
| 30 | NL-4MPR | Speakon EP 4-pole chassis connector       | 4863 |

**POWERCON PLUGS AND SOCKETS**

|    |          |                                 |       |
|----|----------|---------------------------------|-------|
| 31 | NAC3FX-W | Female Powercon True one plug   | 10448 |
| 32 | NAC3MX-W | Male Powercon True one plug     | 10449 |
| 33 | NAC3MPX  | Male Powercon True one socket   | 10450 |
| 34 | NAC3FPX  | Female Powercon True one socket | 10451 |

**NEUTRIK® POWERCON CHASSIS AND CONNECTORS**

|    |          |   |      |
|----|----------|---|------|
| 35 | NAC-3FCA | 240 V 20 A 3-pole male power input cable connector  | 4865 |
| 36 | NAC-3FCB | 240 V 20 A 3-pole male power output cable connector | 4866 |
| 37 | NAC-3MPA | 240 V 20 A 3-pole power input chassis connector     | 4867 |
| 38 | NAC-3MPB | 240 V 20 A 3-pole power output chassis connector    | 4868 |

**NEUTRIK® ADAPTERS**

|    |         |                                       |      |
|----|---------|---------------------------------------|------|
| 39 | NA-3F5M | Female XLR 3 / Male XLR 5 DMX adapter | 4869 |
| 40 | NA-3M5F | Male XLR 3 / Female XLR 5 DMX adapter | 4870 |

**EMBASES RCA**

|    |       |                         |       |
|----|-------|-------------------------|-------|
| 41 | NF2D0 | D-type black RCA socket | 10452 |
| 42 | NF2D2 | D-type red RCA socket   | 10453 |

# MISCELLANEOUS

Adaptaters

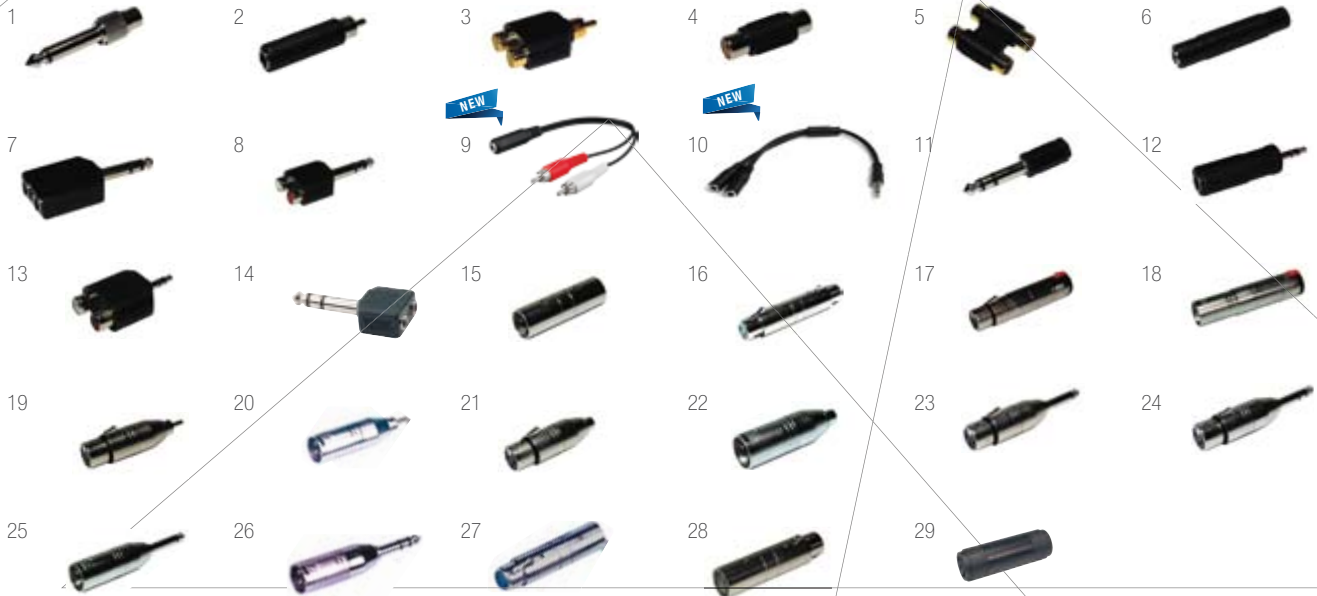

## JACK AND RCA ADAPTERS

|     |           |  |   |       |
|-----|-----------|--|---|-------|
| 1   | ADAPT400  | Female RCA / Male Jack 6.35 mono adapter               | 0505  |       |
| 2   | ADAPT500  | Female Jack 6.35 / Male RCA adapter                    | 0766  |       |
| 3   | ADAPT600  | 2 Female RCA / 1 Male RCA adapter                      | 1656  |       |
| 4   | ADAPT700  | Female RCA / Female RCA adapter                        | 1657  |       |
| 5   | ADAPT750  | 2 Female RCA / 2 Female RCA adapter                    | 7927  |       |
| 6   | ADAPT800  | Female Jack 6.35 / Female Jack 6.35 adapter            | 0767  |       |
| 7   | ADAPT850  | 2 Female Jack 6.35 / 1 Male Jack 6.35 adapter          | 0506  |       |
| 8   | ADAPT900  | 2 Female RCA / 1 Male Jack 6.35 stereo adapter         | 1658  |       |
| NEW | 9         | ADAPT2010  | 1 jack 3.5 female/ 2 x RCA mâle                           | 10697 |
| NEW | 10        | ADAPT2020  | 1x jack 3.5 stéréo mâle / 2x Jack 3.5 stéréo femelle noir | 10698 |
| 11  | ADAPT1000 | Female Jack 3.5 stereo / Male Jack 6.35 stereo adapter | 7928  |       |
| 12  | ADAPT1005 | Female Jack 6.35 stereo / Male Jack 3.5 stereo adapter | 7929  |       |
| 13  | ADAPT1105 | Female RCA stereo / Male Jack 3.5 stereo adapter       | 7931  |       |
| 14  | ADAPT1200 | Jack 6.35 stereo to 2 x Jack 3.5 stereo adapter        | 9278  |       |

## XLR PLUG ADAPTERS

|    |           |                                       |      |
|----|-----------|---------------------------------------|------|
| 15 | ADA/XMXM  | Male XLR / Male XLR adapter           | 2500 |
| 16 | ADA/XFXF  | Female XLR / Female XLR adapter       | 2501 |
| 17 | ADA/XFJF  | Female XLR / Female Jack adapter      | 2502 |
| 18 | ADA/XMJF  | Male XLR / Female Jack adapter        | 2503 |
| 19 | ADA/XFRM  | Female XLR / Male RCA adapter         | 2504 |
| 20 | ADA/XMRM  | Male XLR / Male RCA adapter           | 2505 |
| 21 | ADA/XFRF  | Female XLR / Female RCA adapter       | 2506 |
| 22 | ADA/XMRF  | Male XLR / Female RCA adapter         | 2507 |
| 23 | ADA/XFJM  | Female XLR / Male Jack mono adapter   | 6560 |
| 24 | ADA/XFJMS | Female XLR / Male Jack stereo adapter | 6561 |
| 25 | ADA/XMJM  | Male XLR / Male Jack mono adapter     | 6562 |
| 26 | ADA/XMJMS | Male XLR / Male Jack stereo adapter   | 6563 |

## DMX ADAPTERS

|    |            |                                       |      |
|----|------------|---------------------------------------|------|
| 27 | ADA/XF5XM3 | Female XLR 5 / Male XLR 3 DMX adapter | 7925 |
| 28 | ADA/XM5XF3 | Male XLR 5 / Female XLR 3 DMX adapter | 7926 |

## SPEAKER PLUG ADAPTERS

|    |          |                                |      |
|----|----------|--------------------------------|------|
| 29 | AS/SF-SF | Female/Female speaker extender | 6583 |
|----|----------|--------------------------------|------|

# ELECTRIC ACCESSORIES ET CABLES



|  |              |  |       |
|--|--------------|--|-------|
| <b>MICROPHONE CABLES</b>                       |              |  |       |
| 1  | PROMI/20     | 6 mm black microphone cable - 100m coil                              | 8099  |
|  | PROMI/30     | 6 mm high quality double sheathed black microphone cable - 100m coil | 8100  |
| <b>DMX CABLES</b>                              |              |  |       |
| 2  | DMX-DOUB     | Digital DMX 2-conductor black cable - Sold by the meter              | 8101  |
|  | DMX-QUAD     | Digital DMX 4-conductor black cable - Sold by the meter              | 8102  |
| <b>FLAT SIGNAL CABLE</b>                       |              |  |       |
| 3  | MEP/ASY      | 2 x 4 mm Unbalanced black flat cable - 100 m coil                    | 8103  |
| <b>FLAT SPEAKER CABLE</b>                      |              |  |       |
| 4  | MEP-2075     | 2 x 0.75 Flat speaker cable - R/B 100 m coil                         | 8104  |
|  | MEP-2150     | 2 x 1.5 Flat speaker cable - R/B 100 m coil                          | 8105  |
|  | MEP-2200     | 2 x 2 Flat speaker cable - R/B 100 m coil                            | 8106  |
|  |              |  |       |
| <b>ROUND JACKET SPEAKER CABLES</b>             |              |  |       |
| 5  | PROHP-215    | 2 x 1.5 Black speaker cable - 100 m coil                             | 8107  |
|  | PROHP-225    | 2 x 2.5 Black speaker cable - 100 m coil                             | 8108  |
|  | PROHP-425    | 4 x 2.5 Black speaker cable - 50 m coil                              | 8109  |
|  | PROHP-440    | 4 x 4 Black speaker cable - 50 m coil                                | 8110  |
| <b>HYBRID POWER CORDS</b>                      |              |  |       |
| 6  | DUOLIGHT     | 3 x 2.5 Hybrid power cord + DMX IN and OUT - 50 m coil               | 9854  |
| 7  | DUOSOUND     | 3 x 1.5 Hybrid power cord + AUDIO IN and OUT - 50 m coil             | 9855  |
| <b>HO7RNF TITANEX</b>                          |              |  |       |
| 8  | TIT-315      | 3 x 1.5 Titanex LENS HO7RNF electric cable - 100 m                   | 6755  |
|  | TIT-325      | 3 x 2.5 Titanex LENS HO7RNF electric cable - 100 m                   | 6756  |
| <b>IEC PLUGS AND CHASSIS</b>                   |              |  |       |
| 9  | CEE100       | IEC 22 male chassis plug   | 0227  |
| 10   | CEE200       | IEC 22 female chassis plug   | 1659  |
| 11   | CEE300       | IEC 22 male plug   | 0225  |
| 12   | CEE400       | IEC 22 female plug   | 0226  |
| <b>ELECTRIC PLUGS</b>                          |              |  |       |
| 13   | FIC/MAL      | 2P + G Male plastic plug   | 1804  |
| 14   | FIC/FEM      | 2P + G French female plastic plug                                    | 1805  |
| 15   | FIC/CAH/MAL  | 2P + G French male rubber plug                                       | 1806  |
| 16   | FIC/CAH/FEM  | 2P + G French female rubber plug                                     | 1807  |
| 17   | FIC/SCHU/MAL | IP44 schuko male rubber plug   | 8131  |
| 18   | FIC/SCHU/FEM | IP44 Female rubber plug  | 8132  |
| <b>EXTENSION CORDS</b>                         |              |  |       |
| 19   | ALIM315/3    | HO7RNF3G1.5 Rubber extension cord- 3 m                               | 9848  |
|  | ALIM315/5    | HO7RNF3G1.5 Rubber extension cord- 5 m                               | 9849  |
|  | ALIM315/10   | HO7RNF3G1.5 Rubber extension cord- 10 m                              | 9850  |
|  | ALIM325/3    | HO7RNF3G2.5 Rubber extension cord- 3 m                               | 9851  |
|  | ALIM325/5    | HO7RNF3G2.5 Rubber extension cord- 5 m                               | 9852  |
|  | ALIM325/10   | HO7RNF3G2.5 Rubber extension cord- 10 m                              | 9853  |
| <b>1X2-POLE + EARTH POWER CORD / POWERCON®</b> |              |  |       |
| 20   | CPCIN-1      | Cordon NAC3FCA / 3G1.5mm² / PC16A - 1m                               | 10684 |
|  | CPCIN-2.5    | Cordon NAC3FCA / 3G1.5mm² / PC16A - 2,5m                             | 10685 |
| <b>POWER CORD POWERCON® IN/OUT</b>             |              |  |       |
| 21   | CPCLINK-0.5  | Cordon NAC3FCA/NAC3FCB 3G1.5mm² -0,5m                                | 10692 |
|  | CPCLINK-1    | Cordon NAC3FCA / NAC3FCB 3G1.5mm² - 1m                               | 10693 |
|  | CPCLINK-1.5  | Cordon NAC3FCA/NAC3FCB 3G1.5mm² - 1.5m                               | 10694 |



# ACCESSORIES

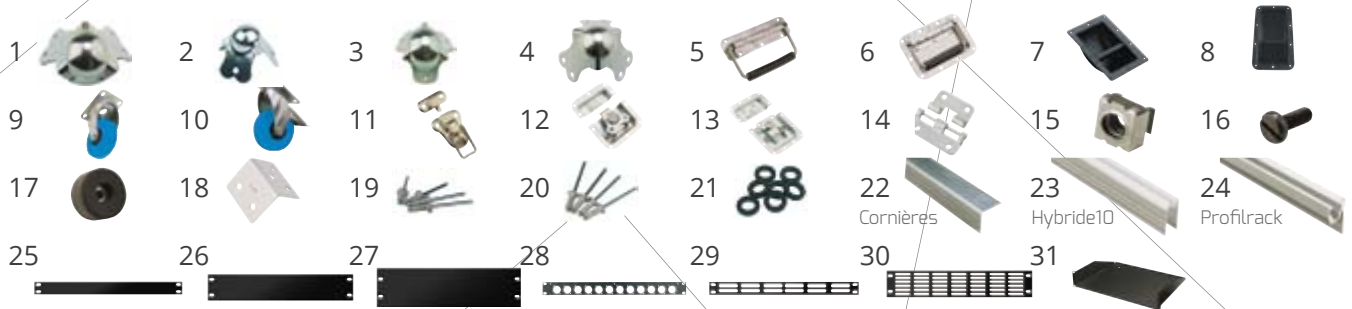

## COINS

|   |          |                                  |      |
|---|----------|----------------------------------|------|
| 1 | COIN2PGM | 2-leg metal corner ball - Large  | 0735 |
| 2 | COIN3PPM | 3-leg metal corner ball - Small  | 0274 |
| 3 | COIN3P   | 3-leg metal corner ball - Medium | 0422 |
| 4 | COIN3PGM | 3-leg metal corner ball - Large  | 0734 |

## HANDLES

|   |               |   |      |
|---|---------------|---|------|
| 5 | POIGNSURF     | Sprung surface handle                   | 0279 |
| 6 | POIGNRENOVI   | Recessed sprung handle                  | 0280 |
| 7 | POIGNMARCH/PM | Marshall metal handle 220 x 160 x 60 mm | 4650 |
| 8 | POIGNMARCH/GM | Marshall metal handle 280 x 160 x 70 mm | 4652 |

## SWIVEL CASTERS

|    |              |  |      |
|----|--------------|--|------|
| 9  | ROUE100      | Swivel caster - diameter 100 mm            | 0288 |
| 10 | ROUE100FREIN | Swivel caster with brake - diameter 100 mm | 0266 |

## LOCKS

|    |            |                          |      |
|----|------------|--------------------------|------|
| 11 | GRENOUILLE | Frog lock                | 0698 |
| 12 | PAPILLONPM | Butterfly latch - Medium | 0287 |
| 13 | PAPILLONGM | Butterfly latch - Large  | 0268 |

## HINGES, NUTS, RIVETS

|    |            |  |      |
|----|------------|--|------|
| 14 | CHARNDEG   | Detachable metal hinge - Large                     | 0289 |
| 15 | ECROUCAGE  | Cage nut for ProfilRack                            | 0270 |
| 16 | VISRACK/12 | Rack screw - diameter 6 mm length 12 mm            | 3085 |
| 16 | VISRACK/16 | Screw for cage nuts - diameter 6 mm length - 16 mm | 0271 |
| 17 | TAMPON     | Rubber foot - Large                                | 0273 |
| 18 | RENFORT    | Corner bead - Large                                | 0290 |
| 19 | VCA412     | 4 x 12 mm Splined rivet (100 per box)              | 8881 |
| 19 | VCA512     | 5 x 12 mm Splined rivet (100 per box)              | 8882 |
| 20 | VCA516     | 5 x 16 mm Splined rivet (100 per box)              | 8883 |
| 21 | V561       | 5,5 x 10 mm Black plastic washers (100 per box)    | 8880 |

## ALUMINIUM PROFILES

|    |            |   |      |
|----|------------|---|------|
| 22 | CORN2020   | 20 x 20 mm Aluminium case angle - 2m long bars - Price per m. | 0283 |
| 22 | CORN3020   | 30 x 20 mm Aluminium case angle - 2m long bars - Price per m. | 0827 |
| 22 | CORN3030   | 30 x 30 mm Aluminium case angle - 2m long bars - Price per m. | 0282 |
| 23 | HYBRIDE10  | Hybrid aluminium lid - 2m long bars - Price per m.            | 0284 |
| 24 | PROFILRACK | Lid maker - 2m long bars - Price per m.                       | 0281 |

## 19 INCHES SHEET METAL

|    |            |  |      |
|----|------------|--|------|
| 25 | TOLE1U/NO  | 19" Black panel - 1 unit                       | 0736 |
| 26 | TOLE2U/NO  | 19" Black panel - 2 units                      | 0737 |
| 27 | TOLE3U/NO  | 19" Black panel - 3 units                      | 0738 |
| 27 | TOLE4U/NO  | 19" Black panel - 4 units                      | 0739 |
| 28 | TOL12XLR   | 1U Sheet metal for 6 male XLR and 6 female XLR | 0423 |
| 29 | TOLE1UV/NO | 1U Vent panel                                  | 0368 |
| 30 | TOLE2UV/NO | 2U Vent panel                                  | 0367 |

## SHELVES

|    |           |          |      |
|----|-----------|----------|------|
| 31 | ETAGERE2U | 2U Shelf | 1626 |
|----|-----------|----------|------|



# **SPEAKER COMPONENTS**



# OUR LOUDSPEAKERS

The AUDIOPHONY® loudspeakers are drawn from our speaker series. You can use them either to replace a part or to upgrade one of your device.

The technical specifications meet the applicable standards and guarantee high quality products.



| LOUD SPEAKER                        | DIAMETER     | IMPEDANCE | POWER OUTPUT | BANDWIDTH    | SENSITIVITY (1W/1M) | Ø COIL       | REF   |
|-------------------------------------|--------------|-----------|--------------|--------------|---------------------|--------------|-------|
| <b>ACTIVE SR SERIES</b>             |              |           |              |              |                     |              |       |
| SRWB10-250                          | 10" (26 cm)  | 4 Ω       | 250 W AES    | 55-2800 Hz   | 96 dB               | 2,5" (65 mm) | 10160 |
| SRWB12-350                          | 12" (31 cm)  | 4 Ω       | 350 W AES    | 45-2800 Hz   | 97 dB               | 3" (77 mm)   | 10161 |
| SRWB15-350                          | 15" (38 cm)  | 4 Ω       | 350 W AES    | 40-3200 Hz   | 98 dB               | 3" (77 mm)   | 10162 |
| <b>COMMERCIAL AUDIO</b>             |              |           |              |              |                     |              |       |
| MIOSW6100                           | 6,5" (16 cm) | 8 Ω       | 100 W RMS    | 52-5000 Hz   | 95 dB               | 2" (52 mm)   | 10151 |
| MIOSW8150                           | 8" (21 cm)   | 8 Ω       | 150 W RMS    | 50-4500 Hz   | 95 dB               | 2" (52 mm)   | 10155 |
| <b>ACUTE SERIES</b>                 |              |           |              |              |                     |              |       |
| ACW08-108                           | 08" (21 cm)  | 8 Ω       | 100 W RMS    | 60-5000 Hz   | 96 dB               | 2" (52 mm)   | 9629  |
| ACW08-104                           | 08" (21 cm)  | 4 Ω       | 100 W RMS    | 60-5000 Hz   | 96 dB               | 2" (52 mm)   | 8742  |
| <b>OCTAVE, COMPACT AND S SERIES</b> |              |           |              |              |                     |              |       |
| SW8-150                             | 08" (21 cm)  | 8 Ω       | 150 W RMS    | 80-2100 Hz   | 94 dB               | 2" (52 mm)   | 9816  |
| SW10-250                            | 10" (26 cm)  | 8 Ω       | 250 W RMS    | 75-2600 Hz   | 96 dB               | 2" (52 mm)   | 9726  |
| OWB6-100                            | 06" (16 cm)  | 8 Ω       | 100 W RMS    | 80-5000 Hz   | 93 dB               | 2" (52 mm)   | 9401  |
| OWB8-108                            | 08" (21 cm)  | 8 Ω       | 150 W RMS    | 80-5000 Hz   | 95 dB               | 2" (52 mm)   | 9630  |
| <b>PORTABLE SOUND SYSTEMS</b>       |              |           |              |              |                     |              |       |
| JOG5-30                             | 05" (13 cm)  | 4 Ω       | 30 W RMS     | 88-15000 Hz  | 88 dB               | 1" (26 mm)   | 9636  |
| JOG5-40                             | 05" (13 cm)  | 4 Ω       | 40W RMS      | 80-15000 Hz  | 88 dB               | 1" (26 mm)   | 9901  |
| SPW10-120                           | 10" (26 cm)  | 8 Ω       | 100 W RMS    | 75-2600 Hz   | 90 dB               | 1" (26 mm)   | 9638  |
| CRW10-180                           | 10" (26 cm)  | 8 Ω       | 150W RMS     | 70-2500 Hz   | 90 dB               | 1" (26 mm)   | 9899  |
| CRW6-60                             | 6,5"         | 8 Ω       | 80 W RMS     | 65-5000 Hz   | 95 dB               | 2" (52 mm)   | 10314 |
| <b>SUBWOOFER</b>                    |              |           |              |              |                     |              |       |
| CW10-150                            | 10" (26 cm)  | 8 Ω       | 150 W RMS    | 48-3000 Hz   | 96 dB               | 2" (52 mm)   | 9301  |
| OWB12-400                           | 12" (31 cm)  | 8 Ω       | 400 W RMS    | 50-3200 Hz   | 96 dB               | 3" (77 mm)   | 9402  |
| OWB15-600                           | 15" (38 cm)  | 8 Ω       | 600 W RMS    | 40-2500 Hz   | 99 dB               | 4" (103 mm)  | 9106  |
| CUBW12-300                          | 12" (31 cm)  | 8 Ω       | 300W RMS     | 45-2800 Hz   | 96 dB               | 2,5" (65 mm) | 10728 |
| CUBW08-150                          | 08" (21 cm)  | 8 Ω       | 150W RMS     | 50-3500 Hz   | 94 dB               | 2" (52 mm)   | 10729 |
| SRWB18-600                          | 18" (46 cm)  | 8 Ω       | 600W RMS     | 30-1000 Hz   | 98 dB               | 4" (103mm)   | 10733 |
| SRWB15-500                          | 15" (38 cm)  | 8 Ω       | 500W RMS     | 35-1000 Hz   | 98 dB               | 4" (103mm)   | 10352 |
| <b>MOJO1000FX</b>                   |              |           |              |              |                     |              |       |
| COWB10-300                          | 10" (26 cm)  | 4 Ω       | 350 W RMS    | 50-5000 Hz   | 96 dB               | 2,5 (65mm)   | 10307 |
| COW4-60                             | 4,75"        | 8 Ω       | 80 W RMS     | 85-5000 Hz   | 94 dB               | 2" (52 mm)   | 10308 |
| <b>MOJO500LINE</b>                  |              |           |              |              |                     |              |       |
| MOJOLINE08                          | 08" (21 cm)  | 8 Ω       | 200 W RMS    | 50-1500 Hz   | 95 dB               | 1,5" (39 mm) | 10585 |
| <b>PASSIVE SR SERIES</b>            |              |           |              |              |                     |              |       |
| SRWB10-250-8                        | 10" (26 cm)  | 8 Ω       | 200 W RMS    | 65-2800 Hz   | 96 dB               | 2,5" (65 mm) | 10317 |
| SRWB12-350-8                        | 12" (31 cm)  | 8 Ω       | 300 W RMS    | 55-2800 Hz   | 97 dB               | 3" (77 mm)   | 10318 |
| SRWB15-350-8                        | 15" (38 cm)  | 8 Ω       | 300 W RMS    | 45-3200 Hz   | 98 dB               | 3" (77 mm)   | 10319 |
| <b>HELIUM</b>                       |              |           |              |              |                     |              |       |
| HLWB10                              | 10"          | 8 Ω       | 300 W        | 47 - 8000 Hz | 93 dB               | 3" (77 mm)   | 10589 |
| HLWB4                               | 4"           | 8 Ω       | 60 W         | 83 - 8000 Hz | 88 dB               | 1" (26 mm)   | 10587 |
| HLWB8                               | 8"           | 8 Ω       | 300 W        | 46 - 500 Hz  | 92 dB               | 2" (52 mm)   | 10588 |

# HF AND LF DRIVERS



**THE AUDIOPHONY® HF DRIVERS ARE VERY SPECIAL COMPONENTS USED IN OUR SPEAKERS.**

The materials we use, such as Mylar or Titanium guarantee an unmatched precision and highly reliable products.

The HF performances heavily rely on numerous factors such as the type of filter used, we strongly advise you to acquire a deep knowledge of these factors before making up your mind.

| DRIVER   | IMPEDANCE<br>(AT 1KHZ) | POWER OUTPUT<br>AT 2 KHZ | BANDWIDTH             | SENSITIVITY<br>(1W/1M) | COIL          | REF   |
|--|------------------------|--------------------------|-----------------------|------------------------|---------------|-------|
| <b>SR SERIES</b>   |                        |                          |                       |                        |               |       |
| SRDR10   | 8 Ω                    | 50 W RMS                 | 1500-20000 Hz         | 94 dB                  | 1" (26 mm)    | 10163 |
| SRDR12 (SR12 et SR15)  | 8 Ω                    | 50 W RMS                 | 1500-20000 Hz         | 96 dB                  | 1,35" (34 mm) | 10164 |
| <b>ACUTE AND COMPACT SERIES + SERIE "S", OCTAVE SATELLITES</b> |                        |                          |                       |                        |               |       |
| ACDR-30  | 8 Ω                    | 30 W RMS                 | 1500-18000 Hz         | 92 dB                  | 1" (26 mm)    | 8838  |
| DIA/ACDR-30  |                        |                          | Diaphragm for ACDR-30 |                        |               | 8839  |
| OCDR-20  | 8 Ω                    | 20 W RMS                 | 1000-20000 Hz         | 93 dB                  | 1" (26 mm)    | 9400  |
| SDR-50   | 8 Ω                    | 50 W RMS                 | 2100-19000 Hz         | 100 dB                 | 1" (26 mm)    | 9815  |
| <b>HELIUM</b>  |                        |                          |                       |                        |               |       |
| HLTR   | 8 Ω                    | 20 W                     | 2500-25000 Hz         | 90 dB                  | -             | 10590 |
| <b>PORTABLE SOUND SYSTEMS SERIES</b>                           |                        |                          |                       |                        |               |       |
| SPDR-20  | 8 Ω                    | 20 W RMS                 | 1000-18000 Hz         | 88 dB                  | 1" (26 mm)    | 9639  |
| JODR-20  | 6 Ω                    | 20 W RMS                 | 1000-18000 Hz         | 88 dB                  | 1" (26 mm)    | 9900  |
| CRDR-20  | 8 Ω                    | 30 W RMS                 | 500-18000 Hz          | 90 dB                  | 1,5" (38 mm)  | 9897  |
| <b>MOJO500LINE</b>   |                        |                          |                       |                        |               |       |
| MOJOLINE-275   | 8 Ω                    | 20 W                     | 1000-20000 Hz         | 96 dB                  | 1" (26 mm)    | 10586 |
| <b>MOJO1000FX</b>  |                        |                          |                       |                        |               |       |
| CODR-20  | 8 Ω                    | 20 W RMS                 | 2100-22000 Hz         | 96 dB                  | 1" (26 mm)    | 10309 |
| <b>CR80A</b>   |                        |                          |                       |                        |               |       |
| CDR-20   | 8 Ω                    | 20 W RMS                 | 2000-20000 Hz         | 90 dB                  | 1" (26 mm)    | 10315 |



# OUR CROSSOVERS

The AUDIOPHONY® passive crossovers are embedded components of our speakers.

They are designed to transform, balance and regulate an incoming signal for a very specific speaker.

Moreover, some of our crossovers are specially calibrated to ensure the tweeter protection. Performances heavily rely on the speakers a crossover was designed for, please analyze carefully the components characteristics before making up your mind.



| CROSSOVER                           | CUT-OFF FREQUENCY | SLOPE     | PUISSANCE ADMISSIBLE | TWEETER PROTECTION | REF   |
|-------------------------------------|-------------------|-----------|----------------------|--------------------|-------|
| <b>ACUTE SERIES</b>                 |                   |           |                      |                    |       |
| AXO-AC08                            | 3,5 kHz           | 12 dB/Oct | 200 W                | Par PTC            | 9631  |
| <b>OCTAVE, COMPACT AND S SERIES</b> |                   |           |                      |                    |       |
| AXO-OCTAVE                          | 2,8 kHz           | 12 dB/Oct | 200 W                | Par PTC            | 9394  |
| AXO-COMPACT                         | 3,2 kHz           | 12 dB/Oct | 200 W                | Par PTC            | 9399  |
| AXO-S6                              | 2 kHz             | 12 dB/Oct | 150 W                | Par PTC            | 9724  |
| AXO-S8                              | 2,1 kHz           | 12 dB/Oct | 200 W                | Par PTC            | 9725  |
| AXO-S10                             | 2,6 kHz           | 12 dB/Oct | 300 W                | Par PTC            | 9727  |
| <b>HELIUM</b>                       |                   |           |                      |                    |       |
| AXOHL                               | 4,5 kHz           | 12 dB/Oct | 200 W                | -                  | 10591 |
| <b>SR SERIES</b>                    |                   |           |                      |                    |       |
| AXO-SR10P                           | 2,1 kHz           | 12 dB/Oct | 250 W                | Par PTC            | 10320 |
| AXO-SR12P                           | 2,1 kHz           | 12 dB/Oct | 350 W                | Par PTC            | 10321 |
| AXO-SR15P                           | 2,1 kHz           | 12 dB/Oct | 350 W                | Par PTC            | 10322 |
| <b>MOJ01000FX</b>                   |                   |           |                      |                    |       |
| AXO-MOJ01000FX                      | 3,2 kHz           | 12 dB/Oct | 80 W                 | Par PTC            | 10310 |

# NOUVEAU CASQUE DE SPORT ASP4

Sans fil, sans contrainte et  
parfaitement étanche\*

\*Wireless, limitless and fully waterproof



by **Play2Run**  
Sport Audio Equipment

# ASP4

Waterproof and foldable sports headset with 4Gb MP3 player  
ref 30156

## DISCOVER THE PLAY2RUN ASP4 THE NEW FULLY WATERPROOF MP3 PLAYER

### PLAY2RUN ASP4

Sport without cable. Sport without smartphone.

Bring your favourite tracks with you during your training thanks to this 4Gb MP3 player. It is compatible with most audio formats, and just needs to be connected to your computer via its connection clip to transfer your audio files.

Its semi-rigid hoop and very low weight (22 grams only) ensure optimal comfort and holding. Its outstanding 12-hour battery life is perfect to support and enhance your sports performance.

The ASP4 also is fully waterproof (IP68) to follow you underwater.

Enhanced ergonomomy to fit your ears in all circumstances.

Fully waterproof.  
Can be used when swimming

Easy-to-access and complete interface with audio assistance







Outstanding battery life and storage capacity to make the fun last



### USB CONNECTION AND TRANSFER CLIP

Its connection pins allow you to charge your MP3 player and transfer your favourite tracks.



|   |   |
|---|---|
|  | <b>WATERPROOF / 1,5 M</b><br>Perfect for running, swimming and triathlon                                      |
|  | <b>SUPER LIGHT / 22 G</b><br>So it does not slow you down   |
|  | <b>LONG-LIFE BATTERY / 12 HOURS</b><br>Never stop training  |
|  | <b>4 GB MEMORY/ 1000 TRACKS</b><br>MP3 and AAC compatible   |
|  | <b>SUPPLIED WITH EARTIPS</b><br>4x waterproof eartips - S, L<br>6x waterproof eartips - S, M, L               |
|  | <b>VOICE PROMPTS</b><br>Vocal help messages gives you the battery life time level, the different mode setting |



# NOUVEAU CASQUE DE SPORT BPH100

Le sport avec un vrai son rock\*

\*Rocking sports





# BPH-100

Bluetooth 4.0 foldable sports headset with internal microphone - CSR-NFC-IP45 - 4 colors



NFC Compatible



BPH-100-BLACK  
ref 30152

**DISCOVER THE PLAY2RUN BPH100  
THE NEW BLUETOOTH PLAYER  
CHEERING FOR YOU**

|  |  |
|--|--|
|  | <b>WEATHERPROOF<br/>AND SWEATPROOF</b>           |
|  | <b>SUPER LIGHT<br/>20 GRAMS</b>                  |
|  | <b>MORE THAN 5<br/>HOURS OF BATTERY<br/>LIFE</b> |
|  | <b>VOICE PROMPTS</b>                             |



BPH-100-RED  
ref 30154



BPH-100-BLUE  
ref 30153



BPH-100-GREEN  
ref 30155

## COMMUNICATE WITH YOUR APPLICATIONS

Communicate with your favourite sports apps. Listen to your coach cheering for you, your timer etc. in real-time to optimise your training sessions thanks to the Bluetooth protocol.

Also allows you to answer and make very clear phone calls thanks to its double built-in microphones.

## ABSOLUTE COMFORT

The new design perfectly fits your ears, plus the adjustable strap guarantees absolute comfort in any position, regardless the effort. Its micro weight of 22 grams will not slow you down, you will not feel any discomfort while training. Rain, and even sweat: it doesn't fear anything.

## HIGH-QUALITY AUDIO

There is no such thing as good sports performances without music. Feel the music thanks to the built-in loudspeaker delivering deep and rich basses to create incredible musical experiences.

However, you will not be cut from the outside world in order to ensure your own safety during your training.

## TECHNICAL SPECIFICATIONS

- Bluetooth v4.1 class1 (CSR solution)
- NFC Compatible
- Supported protocols: HFP / HSP / A2DP / AVRCP
- Battery life:
  - 6 hours when calling
  - 5 hours when playing music
  - 100 hours in Standby mode
- aptX compatible
- Double built-in microphone ensuring the best phone calls quality
- Audio help messages
  - Caller's number identification
  - Battery level (Iphone only)
  - VOIP Compatible

- Voice dialing
- Dimensions: 33,07 x 24,17 x 31,15 mm
- Weight: 20g
- Supplied with:
  - 1 bag
  - 2 ear loops (S and L)
  - 3 eartips (S, M and L)
  - 1 USB cable
  - 1 adjustable strap
  - 1 user guide

# AE20

Battery-operated Bluetooth<sup>®</sup> speaker with built-in microphone

ref 30116



These very comfortable headphones feature a built-in microphone to make hands-free phone calls via any Bluetooth<sup>®</sup> device, and a high audio quality. They are very comfortable and their sleek design blends perfectly into your daily life

The AE20 speaker is compact, light and generates a powerful high-quality sound output. It can be connected to any Bluetooth<sup>®</sup> device and the built-in microphone allows you to receive or make hands-free phone calls.

# BP2200

USB portable charger

ref 30113



Perfect to charge several times your RS4+/SC12 headphones and any smartphone  
You will never be out of battery again  
Supplied with smartphone adapters

# PW2

Dual USB charger

ref 30114



Allows you to simultaneously charge 2 headphones/2 smartphones

\* The Bluetooth<sup>®</sup> trademark and logo are registered by the Bluetooth SIG, inc.

# AB-IP5

Armband for Iphone 5 (or similar phones)  
ref 30117

Designed for Iphone 5, adapts to Iphone 4 as well  
Use your phone without getting it out of the armband  
Anti-sweat system perfect for sport disciplines



# AB-IP6

Ergonomic armband allowing you to transport your smartphone and its accessories  
**Designed for Iphone 6 and compatible with other smartphones up to 4.7"**  
ref 30149



**iPhone 6** **iPhone 5/5s/5c** **Galaxy S3/S4**

# AB-IP6+

Ergonomic armband for smartphone and its accessories  
**Designed for Iphone 6+ and compatible with many other smartphones up to 5.5"**  
ref 30150



**iPhone 6+** **Galaxy Note 3** **Galaxy S4/S5**

# RUNPOCKET

Running belts with 6 gel loops, an extensible pocket and number holder  
ref 30151



**ADJUSTABLE 68-148cm** **6X GEL POCKETS** **EXPANDABLE POCKET** **WEATHER RESISTANT** **SAFETY REFLECTIVE** **0612 LACE LOCKS SYSTEM**

| SPARE PARTS FOR RS4 AND SC12 HEADSETS                          | REF   |
|--|-------|
| CAPS/BLANC - 2x3 Earbuds set - White                           | 30105 |
| CAPS/MULTI - Regular earbuds for RS4 or SC12 - several colours | 30123 |
| SP1/B - Black articulated spare part for RS4 or SC12           | 30118 |
| SP1/W - White articulated spare part for RS4 and SC12          | 30119 |
| SP2/B - Spare RS4 and SC12 USB cable - Black                   | 30110 |
| SP2/W - Spare RS4 and SC12 USB cable - White                   | 30120 |
| SP5/B - SC12 Spare microphone - Black                          | 30125 |
| SPARE PARTS FOR UC2 HEADPHONES                                 |       |
| SP3 - Spare UC2 earcups  | 30121 |
| SP4 - Spare UC2 power cord                                     | 30122 |
| SP6 - UC2 flat Jack/Jack 3.5 cable                             | 30126 |
| SP7 - UC2 protective pouch bag                                 | 30127 |
| SPARE PARTS FOR BP2200 CHARGER                                 |       |
| SP8 - Kit including retractable BP2200 adapters and connectors | 30128 |
| SP9 - BP2200 protective cover                                  | 30129 |

| SPARE PARTS FOR AE SERIES SPEAKERS                          | REF   |
|---|-------|
| SP10 - AE10 USB power cord                                  | 30130 |
| SP11 - AE Series Male Jack 3.5 / Male Jack 3.5 stereo cable | 30131 |
| SP12 - AE10 pouch bag                                       | 30132 |
| SP13 - AE20 USB/Mini USB power cord                         | 30133 |
| SP14 - AE20 protective cover                                | 30134 |
| SP18 - AE20 protective lid                                  | 30138 |
| SPARE PARTS FOR BPH100                                      |       |
| SP20 - Clip-on earphones - Large (58mm) BPH100              | 30157 |
| SP21 - Clip-on earphones - Small (55mm) BPH100              | 30158 |
| SP22 - Spare in-ear black earphone tips BPH100              | 30159 |
| SP23 - Spare in-ear blue earphone tips BPH100               | 30160 |
| SP24 - Spare in-ear red earphone tips BPH100                | 30161 |
| SP25 - Spare in-ear green earphone tips BPH100              | 30162 |
| SP2R26 - USB A to micro USB charge cable BPH100             | 30163 |
| SPARE PARTS FOR ASP4  |       |
| SP27 - Charging clip for ASP4-Black                         | 30164 |



WWW.CONTEST-LIGHTING.COM

- facebook.com/contestlighting
- twitter.com/ContestLighting



WWW.AUDIOPHONY.COM

- facebook.com/audiophony.equipments
- twitter.com/AudiophonyNews



WWW.PLAY2RUN.COM

- facebook.com/Play2Run
- twitter.com/Play\_2\_Run

Conditions are available from your local dealer. Within the limit of available stocks. May contain typographical errors. Because we are always looking for improvement, our products are subject to modifications. The technical specifications, pictures and illustrations are not contractual. Catalogue updated on the 1st March, 2017. AUDIOPHONY®, CONTEST® and PLAY2RUN® are registered trademarks with the INPI and OHMI of HIT MUSIC SAS. Any reproduction of this catalogue, even partially, without the written authorization from HIT MUSIC SAS is prohibited.

Catalogue published by HIT MUSIC SAS - Parc d'Activités CAHORS SUD - EN TESTE - 46230 FONTANES - France.  
Photo credits : Studio ZE and © Shutterstock - Creation : Agence NOVO

More information on [www.hitmusic.eu](http://www.hitmusic.eu)

English version



code 10355